7 700^{CC}

**OPERATING HANDBOOK
FOR STRIPPING, CHECKING AND
ASSEMBLING OPERATIONS**



MOTO GUZZI

SHELL **X100** MOTOR OIL

SEIMM

SOCIETÀ ESERCIZIO INDUSTRIE MOTO MECCANICHE S.p.A.

Capitale sociale sottoscritto: L. 495.000.000

Sede legale: Milano

Galleria de Cristoforis, 3 - Telefono 700965

Direzione e Stabilimenti: 22054 Mandello del Lario (Co)

Telefono: 71112 (4 linee urbane)

Telegrammi: SEIMM MANDELLOLARIO



MOTO GUZZI

V-7 700 cc.

**OPERATING HANDBOOK
FOR STRIPPING, CHECKING AND
ASSEMBLING OPERATIONS**

1 st EDITION

INTRODUCTION

The purpose of this handbook is to supply the necessary instructions for carrying out overhauls and repairs in a rational way.

The data provided here are meant to give a general knowledge about the main checking operations to be carried out when overhauling the different groups.

The handbook is provided with illustrations, drawings and diagrams necessary to carry out stripping, checking and assembling operations.

This handbook will also be a guidance for those who wish to know the manufacturing characteristics of the parts in concern. The knowledge of such characteristics by repairing personnel will be an essential factor for performing a good job.

NOTE - The terms « RIGHT HAND » and « LEFT HAND » used in the text are to be considered as seen from the rider astride the saddle.

I N D E X

	Pag.		Pag.
MAIN FEATURES	5	crankcase	33
TOOLS FOR OVERHAULING	9	Push rods	33
DESCRIPTION OF ENGINE	10	Rockers	34
REMOVAL OF « ENGINE-GEARBOX » GROUP FROM FRAME	11	Coupling data of rocker arms and splindles	34
ENGINE OVERHAUL	12	Tappet clearance adjustment	34
Stripping of engine	12	Valve timing	34
ROCKER BOX COVERS - CYLINDER HEADS - VALVES - GUIDES - SPRINGS	16	SUMMING UP OF DATA PERTAINING TO TIMING PARTS	37
Stripping	16	ENGINE LUBRICATION	38
Removal of springs and valves	16	Description	38
Inspection and overhaul of cylinder heads	16	Oil pump	38
Inspection and overhaul of valve guides	16	Inspection and checks	38
Valves-valve guides coupling data	17	Oil cleaner	39
Inspection and overhaul of valve seats in cylinder heads	17	Oil piping	40
Inspection of valves	18	Oil pressure solenoid	40
Inspection of valve springs	18	Oil breather	40
Valves sealing test	18	Oil pressure gauge	40
Assembling of cylinder heads on cylinders	19	ENGINE ASSEMBLING	41
CYLINDERS - PISTONS - PISTON RINGS AND OIL SCRAPERS	20	ENGINE FEEDING	43
Cylinders wear check	20	Fuel tank	43
Selection of cylinders diameter	20	Air cleaner on carburetors	44
Pistons	21	Carburetors	44
Selection of piston diameter	22	Standard carburetor settings	45
Piston rings and oil scrapers	22	Idling speed adjustment	45
Piston rings and scrapers-piston slots height clearance	22	Top speed adjustment and main jet selection	46
Piston ring and oil scrapers clearance	22	Stripping of carburetor	46
Fitting of piston pins	22	Servicing of carburetor	46
CON - RODS - CRANKSHAFT - MAIN BEARING, Flywheel side - MAIN BEARING, Timing side	23	ENGINE BRAKE TEST	48
Con-rods	23	CLUTCH	49
Thickness of big end bearings	23	Removal of clutch assembly	49
Diameter of crankshaft pin	23	Checking clutch springs	49
Small end bushing	24	Checking pressure plate	50
Checking weights for engine balancing	24	Checking driven plates	50
Checking parallelism of end axis	25	Checking intermediate plate	50
Fitting up con-rods on crankshaft	25	Checking starting ring gear	50
Crankshaft	27	Clutch assembling operation	50
Diameter of main journal, flywheel side	28	Clutch control	50
Diameter of main journal, timing side	28	Checking clutch control	50
I/D of main bearing, flywheel side	28	Checking clutch operating lever on gearbox	50
I/D of main bearing, timing side	28	Outer body	50
Flywheel side flange complete with main bearing	29	Cage c/w balls	50
Seal ring for flywheel side flange	29	Inner body	50
Timing side flange c/w main bearing	29	Pressure rod	50
Timing cover	29	Pressure rod cap	51
Timing cover seal ring	29	Outer body seal ring	51
Crankcase	29	Clutch adjustment	51
Inspection and overhaul of crankcase	30	GEAR BOX	52
Wear check of tappet guides in crankcase	30	Gear box description	52
SUMMING UP OF DATA PERTAINING TO CRANK MECHANISM PARTS	31	Gear box control	52
TIMING DATA	32	Gear box stripping	53
Camshaft	32	Gear box	55
Diameter of crankshaft bearings and their housings on crankcase	32	Gear box cover	55
Checks	32	Check and overhaul of the gear box unit parts	56
Tappets	33	Gear box and cover	56
Coupling data of tappets and tappet guides in	33	Seal rings	56
		Ball bearings and roller bearings	56
		Mainshaft	56
		Layshaft	56
		Fitting clearance between gear bushings and layshaft	56
		Layshaft gears	56
		Fitting clearance between bushings and gears on layshaft	56
		Sliding muff	57
		Clutch shaft	57

	Pag.		Pag.
Clutch shaft seal ring	57	Brake springs	74
Inner body	57	Brake cam.	74
Cush drive shaft semi-collar	57	Brake pins	74
Cush drive plate	57	Brake drums	74
Cush drive spring	57	Rear wheel central body	74
Sliding sleeve	57	Hub seals	74
Idle gear	57	Tapper roller bearing housings	74
Gear selector drum	57	Tapper roller bearings	74
Preselector shaft, with sector gear	57	Adjusting washers	74
Preselector shaft return spring	57	Brake cam lever	74
Gearshift operating lever	57	Front brake cable	75
Gear selector forks and fork shafts	57	Front brake adjustment	75
Assembling of gear box	58	Rear brake adjustment	75
REAR WHEEL DRIVE	59	Assembling of wheels	75
Description	59	Assembling of front wheel hub	75
Stripping of rear wheel drive	59	Fitting front wheel on fork	76
Check and overhaul of rear wheel drive assembly	60	Assembling rear wheel hub	76
Rear wheel drive box	60	Fitting rear wheel on fork and drive box	76
Drive box flange	60	TAPER ROLLER BEARINGS AND BALL BEARINGS	77
Distance shims	60	FRAME	78
Internal toothed sleeve for rear wheel coupling	60	Check and overhaul	78
Bevel gear set	60	Rear fender and tool boxes	78
Cage retaining ring	60	Center and side stand return springs	78
Rear wheel - drive box distance piece	60	Crashbar	78
Bearing housing	60	Rear brake control lever, spindle and rod	78
Adjusting washers	61	Rider and pillion footrests	78
Shims	61	Assembling	78
Bevel gear distance piece	61	ELECTRICAL EQUIPMENT	79
Lockring safety washer	61	BATTERY	79
Lockring	61	Features	79
Seal rings	61	Inspection and maintenance	79
Drive shaft-bevel pinion sleeve	61	Cleaning	79
Drive shaft	61	Check and smearing of terminal blocks	79
Double joint	61	Electrolyte level	79
Bands	61	Charge check	80
Rubber gaiters	61	Common battery faults	81
Ball bearings and taper roller bearings	61	GENERATOR	83
Assembling of rear wheel drive	61	Description	83
Assembling rear wheel drive to R/H arm of rear fork	62	Operation	83
Contact check and adjustment of bevel gear teeth	63	Regulator unit	83
REAR SUSPENSION	65	Testing data	86
Stripping from frame	65	Adjustment of generator belt tension	87
Check and overhaul	65	Generator faults	88
Flexible bushings	65	STARTER MOTOR	94
Fitting up on frame	65	Description	94
FRONT SUSPENSION AND STEERING	66	Operation	95
Stripping of telescopic front fork and steering	66	Testing data	97
Overhaul of telescopic front fork and steering	67	Starter motor faults	99
Fork rods	67	IGNITION SYSTEM	103
Top bushings	67	General information	103
Bottom bushings	67	Coil	103
Fork bottom covers	67	Distributor	104
Fork springs	68	Automatic spark advance device	104
Spring housings	68	Contact breaker	105
Top plug rubber rings	68	Condensor	105
Top plug seals	68	Distributor cap and rotor	105
Steering taper roller bearings	68	Spark plugs	105
Steering adjusting lockrings	68	Ignition timing	106
Steering tube	68	Ignition faults	108
Assembling fork and steering on frame lug	68	ELECTRIC HORN	113
STRIPPING OF REAR SWINGING FORK	70	Overhaul and repair instruction	113
Overhaul of rear fork	70	Testing data	114
Nuts and locknuts	70	Electric horn faults	115
Support spindles	70	LIGHTING	117
Seals	70	Head light	117
Ball bearings and taper roller bearings	71	Instruments panel	117
Fitting up rear fork	71	Tail light and stop light	117
WHEELS AND BRAKES	72	Fuses	117
Front wheel	72	INSTRUMENTS AND CONTROLS	118
Rear wheel	72	Wiring diagram legend	119
Wheels and brakes check	73	LUBRICATION AND GENERAL MAINTENANCE CHART	121
Wheels	73		
Rims	74		
Spokes	74		
Brake linings	74		

MAIN FEATURES

ENGINE

Cycle	: 4 strokes
Number of cylinders	: 2
Cylinder disposition	: « V » - 90°
Bore	: 80 mm. (3.149")
Stroke	: 70 mm. (2.755")
Displacement	: 703.717 cc. (42.93 cu. in.)
Compression ratio	: 9 to 1
Revs at max engine speed	: 6000 r.p.m.
Output at max engine speed	: 50 HP SAE
Crankcase	: in light alloy
Cylinders	: light alloy barrels with hard chrome linings
Cylinder heads	: in light alloy, hemispherical, with special cast iron inserted valve seats
Crankshaft	: steel construction
Crankshaft supports	: of anti-friction material pressed in suitable housing (as used in all F1 Race cars)
Connecting rods	: steel construction with AL-TIN alloy thin wall bearings
Pistons	: in light alloy

Valve gear

O.H.V., push rod operated via the camshaft in the crankcase and gear driven by the crankshaft.

Inlet:

- opens 24° before TDC
- closes 58° after BDC

Exhaust:

- opens 58° after BDC
- closes 22° after TDC

Rocker clearance for valve timing:

- 0,5 mm. (.0196")

Normal rocker clearance (cold engine):

- inlet 0.1 mm. (.00393")
- exhaust 0.2 mm. (.00787")

Carburation

Both carburetors are gravity fed from the tank.

Carburetor Make:

type Dell'Orto S.S.I. (right and left)

Lubrication

Pressure, by gear pump driven by the crankshaft.

Oil strainer in crankcase.

Normal lubricating pressure 2.5 - 3 kgs./sq. cm. (35.6 - 42.7 lbs/sq.in.)

(Controlled by relief valve)

Electrically controlled oil pressure gauge.

Cooling

By air. Cylinder and cylinder heads deeply finned.

Ignition

By battery with automatic advance Marelli distributor type S 123 A.

Initial advance: 10°.

Automatic advance: 28°.

Ignition timing 38° full advance.

Contact breaker gap: 0.42-0.48 mm. (.016-.018").

Spark plug: n. 225 in Bosch-Marelli scale or equivalent.

Plugs point gap: 0,6 mm. (.023").

Ignition coil: Marelli BE 220 D.

Starter motor

Marelli starter MT 40 H (12 V - .7 HP) with electromagnetic ratchet control. Ring gear bolted on flywheel.

Exhaust system

Dual exhaust pipes and mufflers.

TRANSMISSION

Clutch

Twin driven plates, dry type, located on the flywheel. Controlled by lever on left handlebar.

Gear box

Four speeds, frontal engagement. Constant mesh gears. Cush drive spring incorporated.

Separate case bolted on crankcase, operated by rocker pedal on the right hand side of the machine.

Engine-gearbox ratio: 1 to 1.373 (16-22)

Internal gear ratios:

— Low gear	1 to 1.933	(15-29)
— Second gear	1 to 1.263	(19-24)
— Third gear	1 to 0.954	(22-21)
— High gear	1 to 0.754	(24-18)

Secondary drive at rear wheel

By constant speed homokinetic double joint cardan shaft.

Bevel layshaft gear-wheel ratio: 4.625 (8-37)

Overall gear ratios:

— Low gear	1 to 12.292
— Second gear	1 to 8.031
— Third gear	1 to 6.066
— High gear	1 to 4.794

FRAME

Duplex cradle, tubular structure.

Suspension

Rear swinging fork with external adjustable springs.

Telescopic front fork incorporating hydraulic dampers.

Telescopic front fork with external adjustable spring.

Wheels: 18x3 spoked steel rims, front and rear.

Wheels: 18x3 spoked steel rims, front and rear.

Tires

4.00 x 18 front and rear, block type « high speed ».

Front tire pressure

Solo rider	} 1,5 kgms/sq. cm. = 21 P.S.I.
With pillion	



Rear tire

Solo rider 1,8 kgms/sq. cm. = 25 P.S.I.
With pillion 2,0 kgms/sq. cm. = 28 P.S.I.

Note - The above recommendation is for normal riding (cruising speed). If using the machine at constant high speed or on motorways the above pressures should be increased by 0,2 kgms/sq. cm. (2,8 P.S.I.).

Brakes

Twin leading shoes expanding type front brake, operated by hand lever on the right handlebar.

Large rear brake operated by pedal on left hand side of machine.

Overall dimensions and weight

— Wheelbase	1.445 mts. (abt. 56.9")
— Length	2.230 mts. (abt. 87.5")
— Width	0.795 mts. (abt. 31.2")
— Height (dry)	1.050 mts. (abt. 41.2")
— Minimum ground clearance	0.150 mets. (abt. 5.9")
— Curb weight	243 kgs 536 Lbs

Performance

Maximum permissible speed and gradients climbable in each gear, solo riding.

Low gear 66 Kms/h (41 m.p.h.) Climbing ability 60%

Second gear 96 kms/h (59.6 m.p.h.) Climbing ability 34³/₀

Third gear 120 kms/h (74.5 m.p.h.) Climbing ability 23³/₀

High gear 170 kms/h (106 m.p.h.) Climbing ability 14³/₀

Capacities

Fuel tank: 20 liters (5.28 US gls.) including about 4 liters reserve (about 1 USA gl) - Petrol 98/100 No (Regular octane) Sump 3 liters (3³/₄ Quarts) Shell Multigrade 20/40 - Transmission 0.750 liters (1³/₄ Pints) Shell Spirax 90 E. P. - Rear wheel drive 0.300 liters (5/8 Pints) Shell Spirax 90 E. P. - Front fork dampers 0.160 liters = 5,4 oz USA « Shell Tel-lux 33 ».

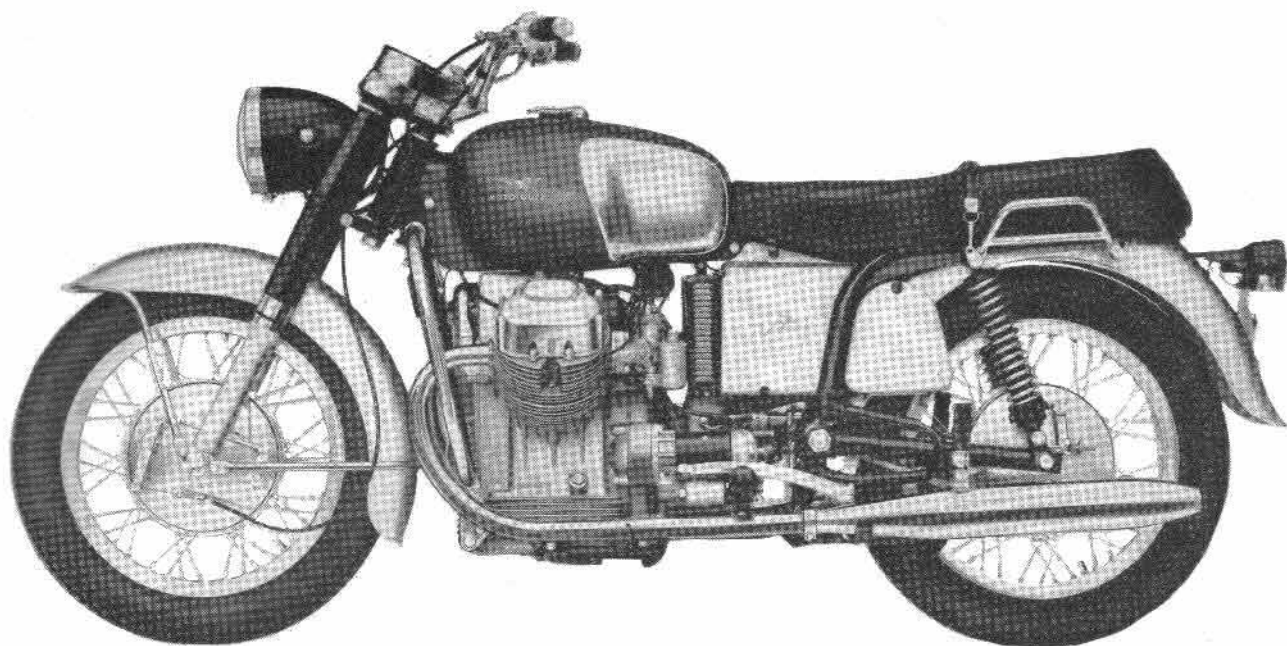

Fig. 1 - Left view

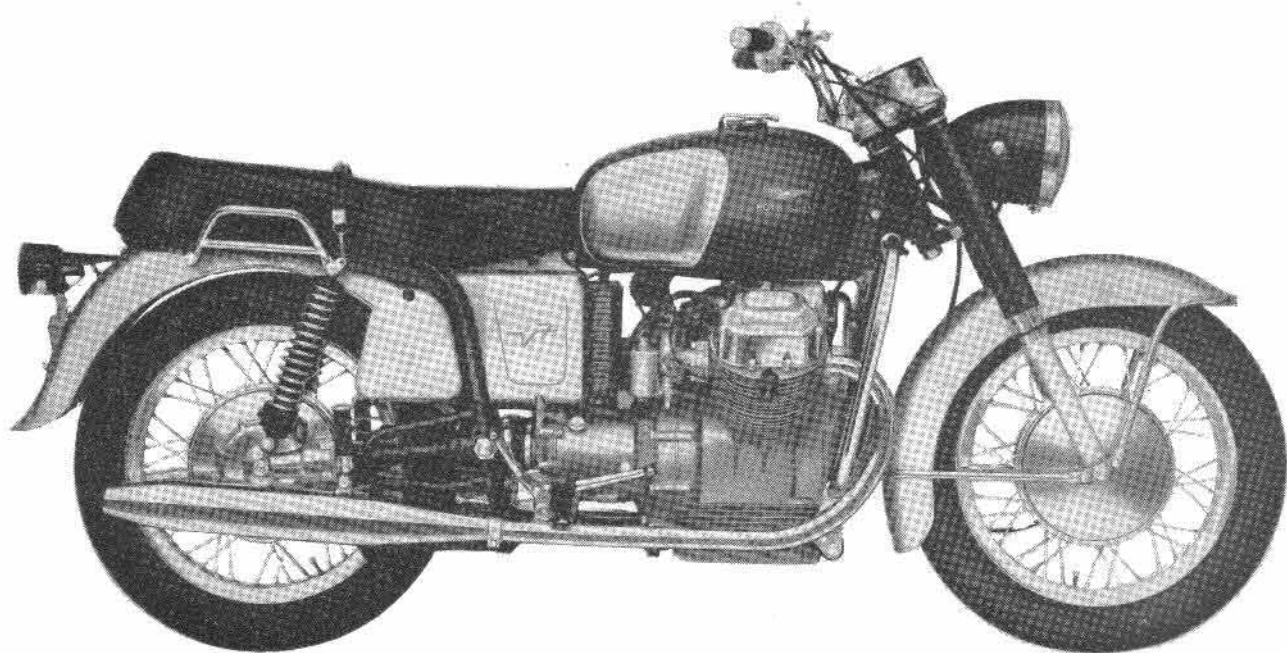

Fig. 2 - Right view

TOOLS REQUIRED FOR STRIPPING, CHECKING AND REASSEMBLING (see Fig. 3)

Fig. No.	Order No.	Description
1	12904700	Puller for taper bearing races on rear fork.
2	12906900	Puller for roller bearing race in drive box.
3	60910500	Steering top linking plate puller.
4	12909500	Front fork rods assembling tool.
5	12905400	Wrench for removal of layshaft lockring.
6	12912700	Lockring adjusting tool for rear dampers.
7	60907200	Valve dismantling and assembling tool.
8	12913700	Puller for layshaft ball bearing in transmission box.
9	12913100	Puller for mainshaft roller bearing in transmission box.
10	12907000	Puller for mainshaft and clutch shaft bearings in transmission box cover.
11	12912600	Special wrench for front fork lockring.
12	12912000	Flange assembling and oil seal locating tool on crankshaft, flywheel side.
13	12903000	Tool for rear fork taper roller bearing adjustment.
14	12910700	Bush for oil seal fitting on mainshaft.
15	32906302	Oil pump gear puller.
16	12911801	Flywheel and clutch unit holding tool.
17	26907800	Piston pin puller.
18	12907100	Layshaft and rear drive bevel holding tool.
19	12913600	Tool for removing the flange c/w bearing, flywheel side.
20	12912900	Special tool to check positioning marks on timing gears.
21	12906500	Clutch dismantling and assembling tool.
22	12908300	Tool for timing cover assembling and oil seal locating on crankshaft, timing side.
23	12905900	Tool for removal of clutch shaft.
24	12905300	Tool for holding crankshaft when removing bevel nut.
25	12913800	Tool for transfer of positioning marks on timing gear.

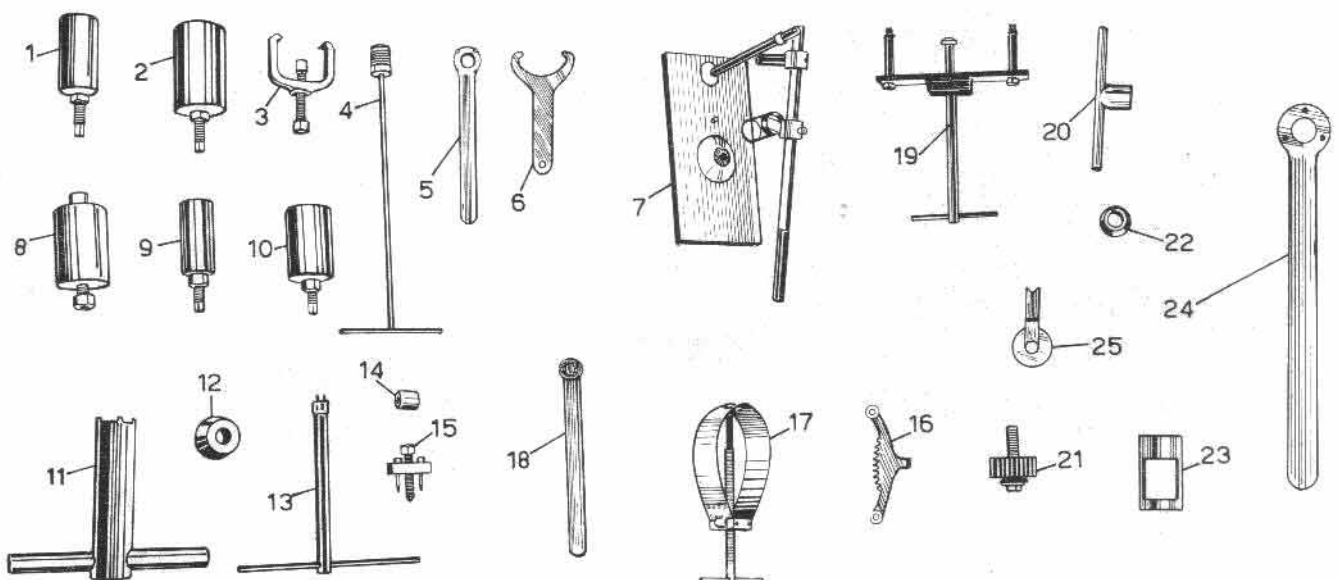

Fig. 3

DESCRIPTION OF ENGINE

(see Fig. 4 & 5)

The « V7 » model is equipped with a twin-cylinder 90° V engine. Cylinders have light alloy barrels with hard chrome linings and are deeply finned for cooling.

Cylinder bottoms fit into suitable housings in crankcase.

Crankcase in light alloy, provided with six bolts (four long, two short) to secure cylinders and cylinder heads.

Cylinder heads are in light alloy, with special cast iron inserted valve seats.

Rocker box covers in light alloy. Steel construction crankshaft on two special tin-aluminium alloy main bearings, pressed in suitable housings.

Steel construction con-rods with thin wall bearings at big ends and bronze bushes at small ends.

Piston in light alloy, with 4 rings: 3 over pin (two piston rings and one oil scraper) and 1 below pin (oil scraper).

O.H.V. valve gear, operated through camshaft, tappets, push rods and rockers. Camshaft gear driven by crankshaft. Carburetors are gravity fed. Pressure lubrication from oil sump through gear

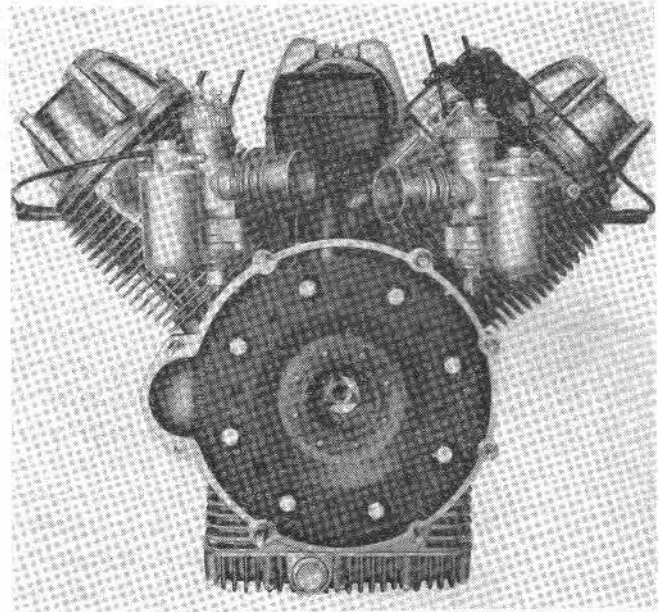

Fig. 4

pump driven by crankshaft. Oil recovery by gravity. Wire gauze type oil cleaner in crankcase. Lubrication pressure controlled by relief valve. Breather tube conveys oil vapors into breather box from which, after condensation, oil returns into sump.

Pressure is discharged outside through vent tube. Engine is air cooled. Cylinders and cylinder heads are suitably finned.

Ignition by battery, coil and distributor operated by crankshaft through built-in gear.

Electric starting, electrically controlled.

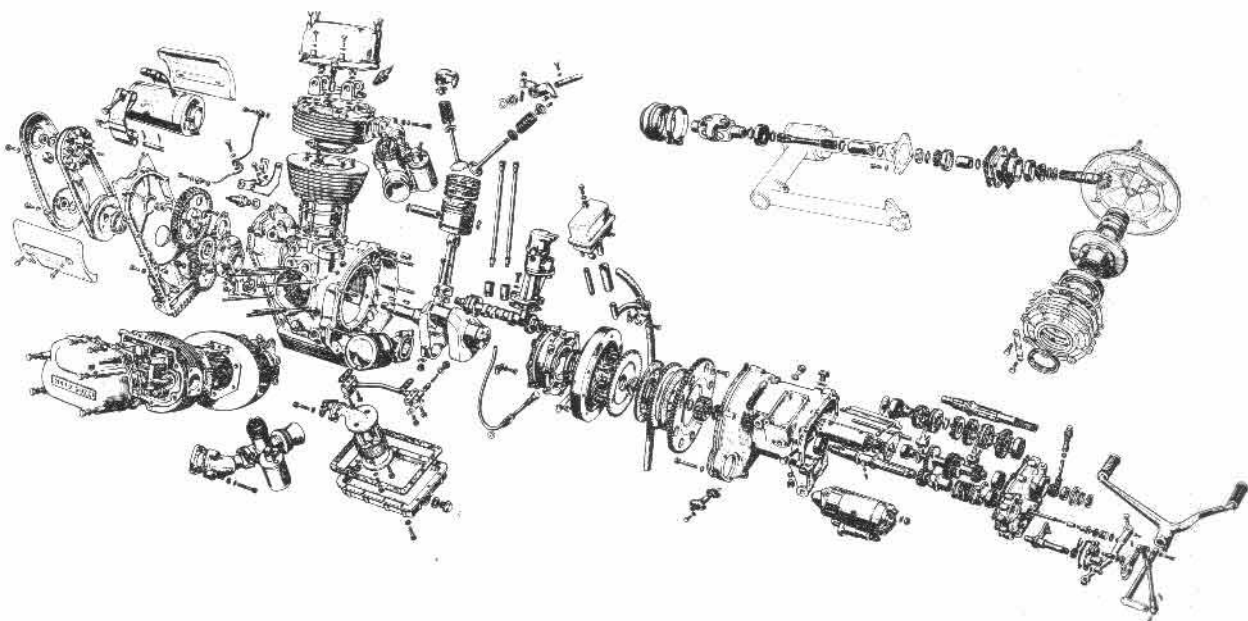

Fig. 5

REMOVAL OF «ENGINE-GEARBOX» GROUP FROM FRAME

(see Fig. 6)

For the removal of the « engine-gearbox » group from frame,, remove the following:

- battery covers (L/H & R/H) and disconnect cables from battery.
- speedo control cable from transmission in gearbox.
- saddle, fuel tank and battery, after removal of holder bracket.
- throttle and air cables two-ways adapter, without disconnecting cables.
- battery support plate, clutch control cable from lever on gearbox, starter control electric cables and neutral indicator cable from gearbox.
- coil, after disconnecting electric cables; dis-

tributor cap, after disconnecting spark plugs cables; distributor rotor.

- generator covers; generator belt guard and generator unit.
- mufflers, large band on rubber gaiters.

Put engine on a support and after unscrewing nuts extract bolts securing « engine-gearbox » group to frame; move the group forward (towards front wheel) tilting it to the right then extracting it from frame.

N.B.: The above operation is suggested to be carried out by **two** mechanics.

After removal of group from frame, wash same with petrol and dry by compressed air. Then strip engine assy from gearbox assy.

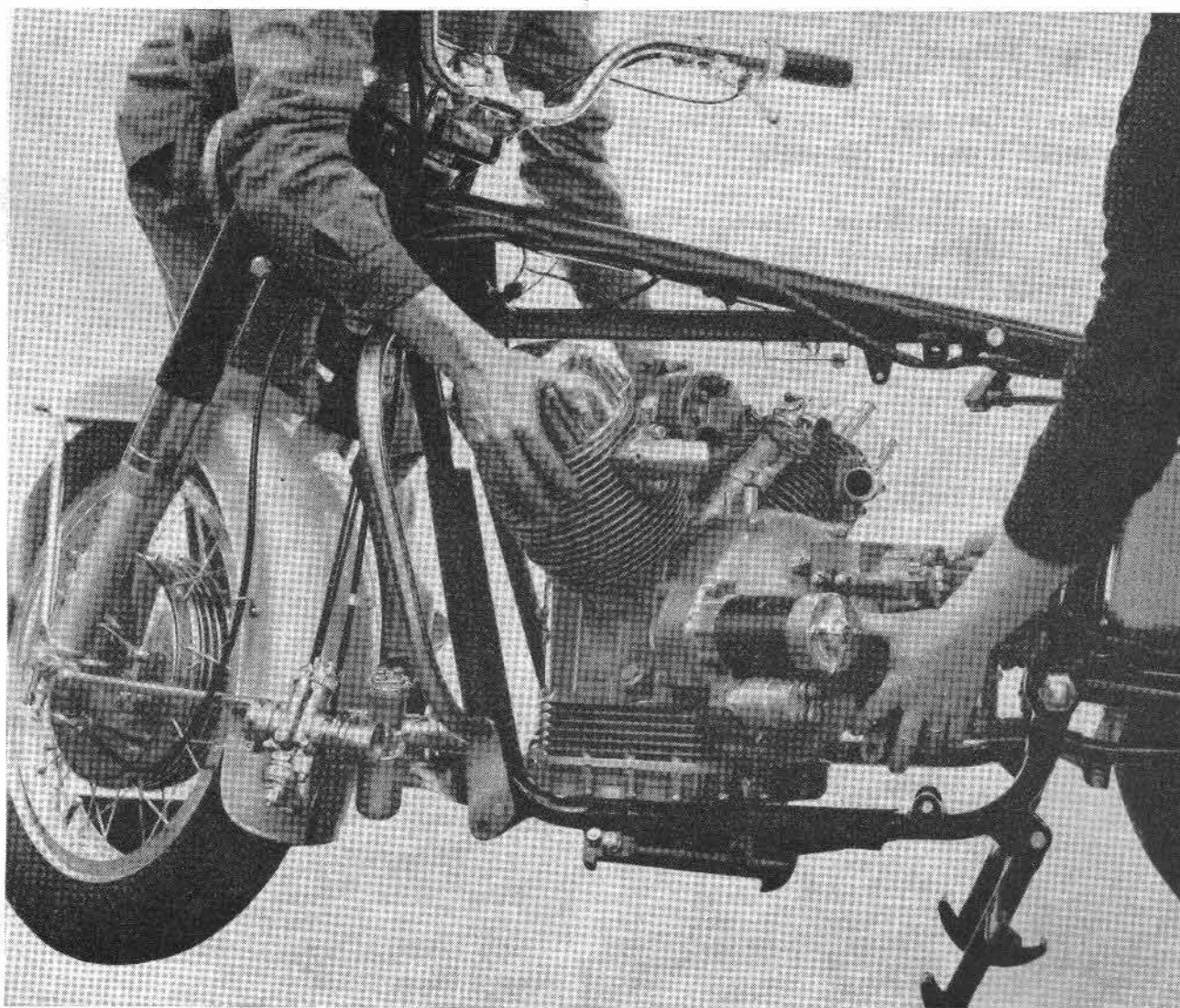

Fig. 6

ENGINE OVERHAUL

ENGINE STRIPPING

To strip remove the following:

- drain oil from sump by unscrewing oil drain plug (see B on Fig. 7).
- remove spark plugs.
- ignition distributor unit c/w support, after unscrewing bolts securing same to crankcase and removing gasket.
- generator securing band, after removal of cotter pins and pins.
- generator support bracket, after unscrewing bolts securing same to crankcase.
- clutch unit, unscrewing bolts securing starter ring gear by means of ring wrench and tool No. 12911801 (see 16 on Fig. 8). Bear in mind that such bolts must be unscrewed in crossed sequence. After removal of ring gear remove

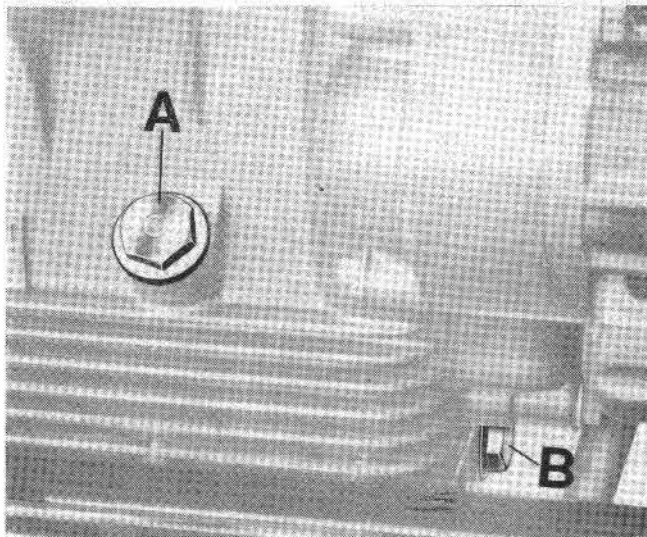

Fig. 7

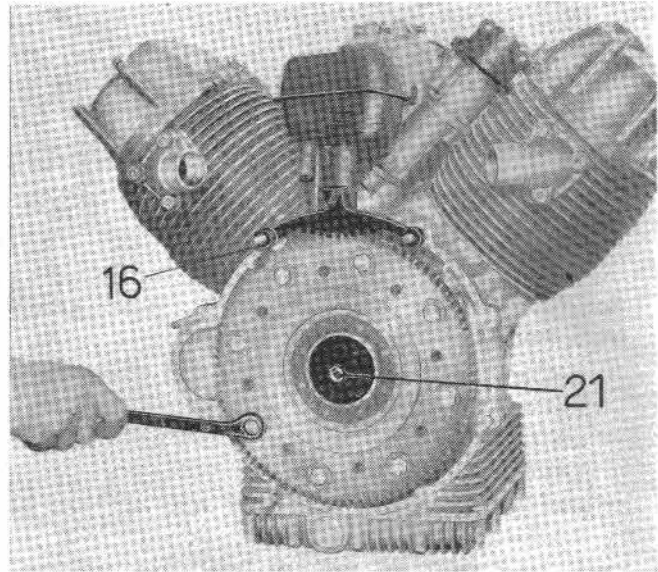

Fig. 8

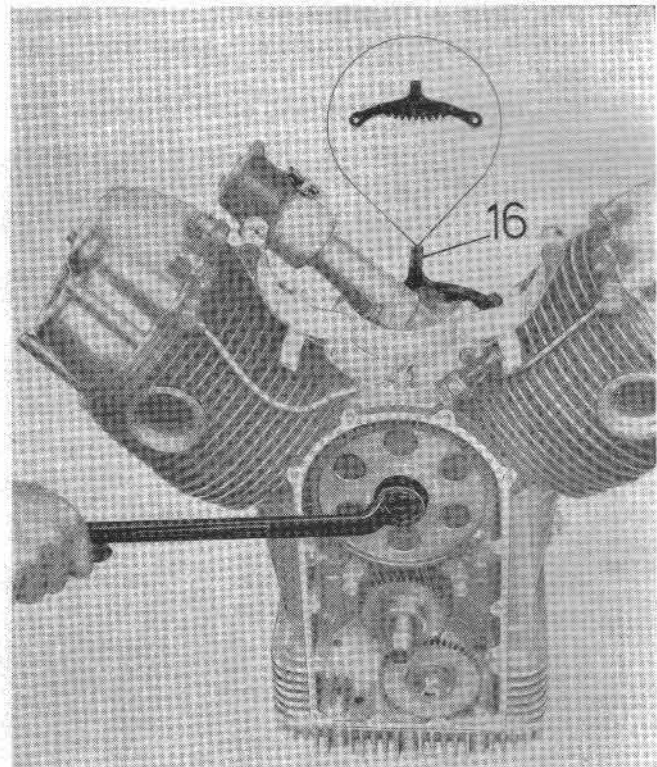

Fig. 9

n.s. clutch plate, intermediate plate, f.s. clutch plate, pressure plate, washer and springs.

- generator driving pulley, after unscrewing nut on crankshaft by means of ring wrench and tool No. 12911801.
- timing cover, after unscrewing bolts securing same to crankcase.

- seal ring from timing cover.
- cam wheel, removing nut securing same to camshaft, by means of ring wrench and tool No. 12911801 (see 16 on Fig. 9).
- oil pump gear, by means of tool No. 12911801 (see 16 on Fig. 10) and oil pump gear puller No. 32906302 (see 15 on Fig. 10).
- distribution gear.
- flywheel. After flattening the lock plates, unscrew bolts securing flywheel to crankshaft, by means of box wrench and tool No. 12911801 (see 16 on Fig. 11).
- cylinder head lubrication oil pipe.
- rocker cover screws, then remove covers and gaskets.
- rocker spindle bolts and washers.

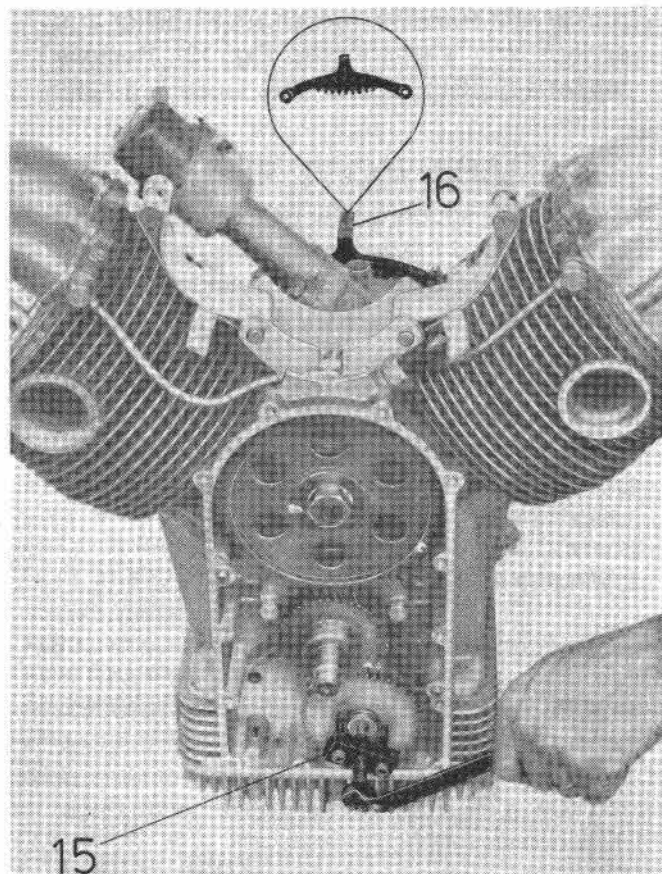

Fig. 10

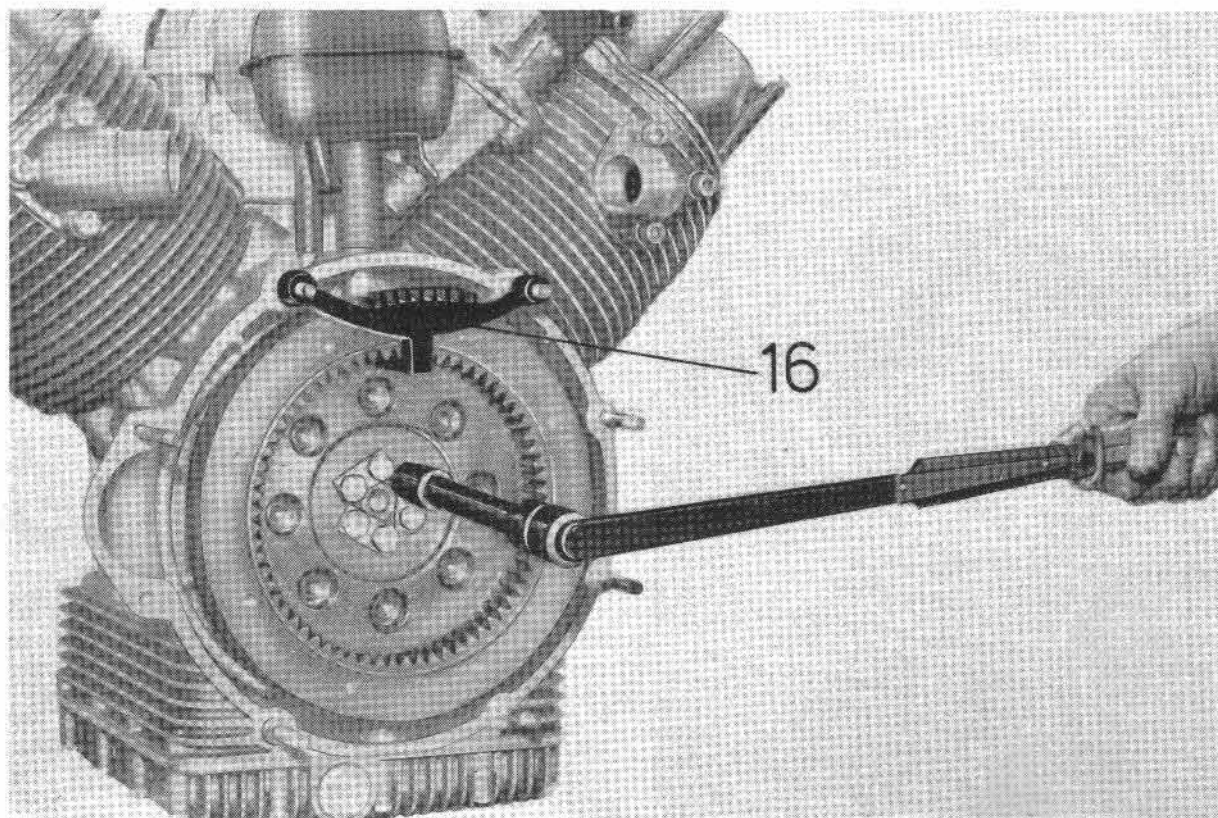

Fig. 11

- rocker arm spindles, rocker arms, rocker arm springs and washers (see Fig. 12). Remove tappet adjusting screws after loosening nuts.
- push rods.
- rocker arms support, after unscrewing the four long bolts and the two short bolts (each head) which secure cylinder and cylinder head to crankcase.
- cylinder heads c/w valves and remove gasket. Using tool No. 60907200 (see 7 on Fig. 13) remove from cylinder head the semicones, top collars, springs, bottom collars and then extract valves from inside.
- cylinders and relative gasket.
- tappets from housing on crankcase.
- piston pin, by means of puller No. 26907800 (see 17 on Fig. 14), after removal of circlips.
- the piston and from same remove piston rings.
- oil sump, after unscrewing screws securing same to crankcase. Also remove oil sump gasket.
- oil pump, after removing screws securing same to crankcase. From pump remove key, driven gear and driving shaft.

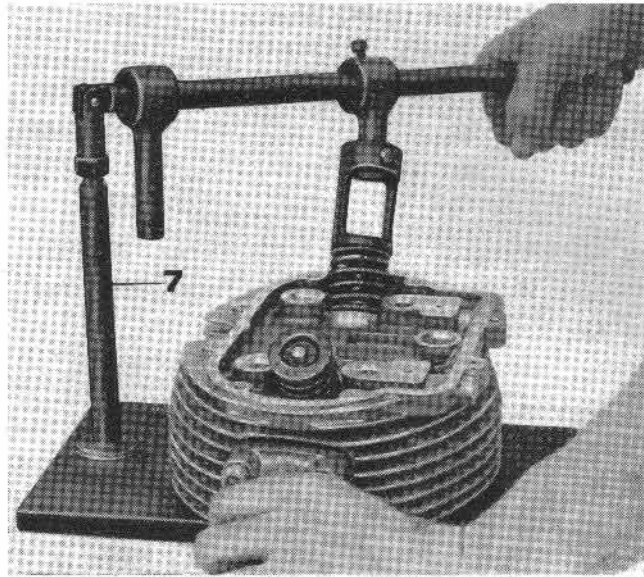

Fig. 13

- complete oil cleaner and gasket (see B on Fig. 15). Cleaner consists of: 2 retaining bolts, bottom plate, wire gauze and cleaner body.
- oil pipe (see A on Fig. 15), after flattening lock plates and unscrewing securing bolts and washers. Remove from pipe the pressure relief valve, consisting of: plunger, spring, bottom plate and plug.
- con-rod caps, after flattening lock plates and unscrewing nuts. Then extract con-rods from

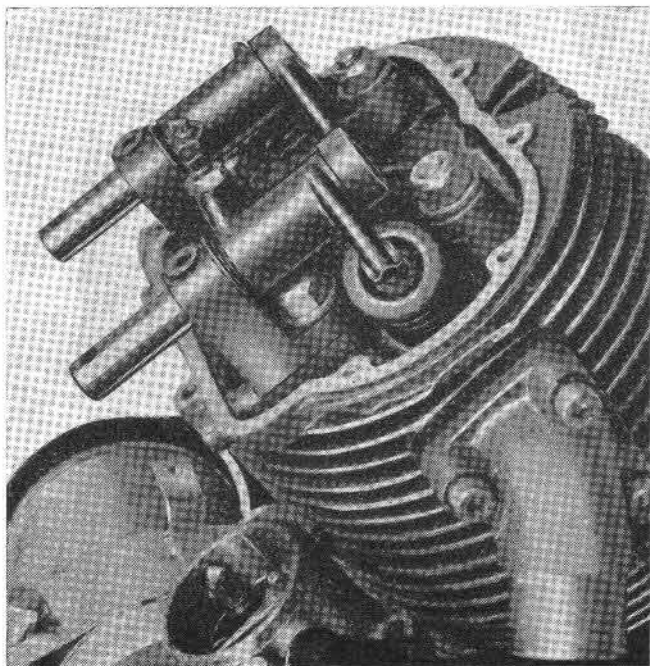

Fig. 12

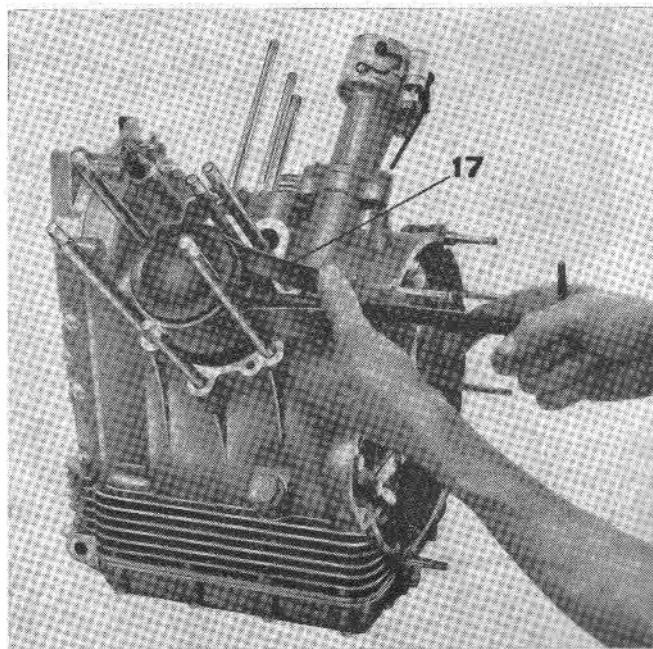

Fig. 14

top of crankcase. Remove half bearings from con-rods.

- camshaft, after unscrewing bolts securing flange to crankcase.
- flange c/w crankshaft bushing, timing side, after flattening lock plates and unscrewing bolts securing flange to crankcase.
- flange c/w main bearing, flywheel side, after flattening lock plates and unscrewing bolts securing flange to crankcase. Then, by means of tool No. 12913600 (see 19 on Fig. 16) remove flange c/w main bearing from crankcase.
- crankshaft.
- oil pressure solenoid.
- oil filler plug (see A on Fig. 7).

After the above operations the crankcase is completely stripped, except for the long and short bolts.

N.B.: During stripping it is strongly recommended to keep well apart the two « cylinder-rod-piston » groups.

To remove timing cover without removing engine from frame, it is necessary to proceed as follows:

- after removing belt cover and generator belt, unscrew the three bolts securing pulley assembly. Extract pulley outer flange and washers.
- using the three bolts previously securing pulley, fit tool No. 12905300 on pulley hub (see 24 on Fig. 17) and thus holding crankshaft, unscrew crankshaft nut by means of a ring wrench.
- unscrew the three bolts and remove special tool, inner body of pulley and pulley hub.
- block or support engine.
- remove bottom frame/engine stud.
- remove screws securing timing cover to crankcase.

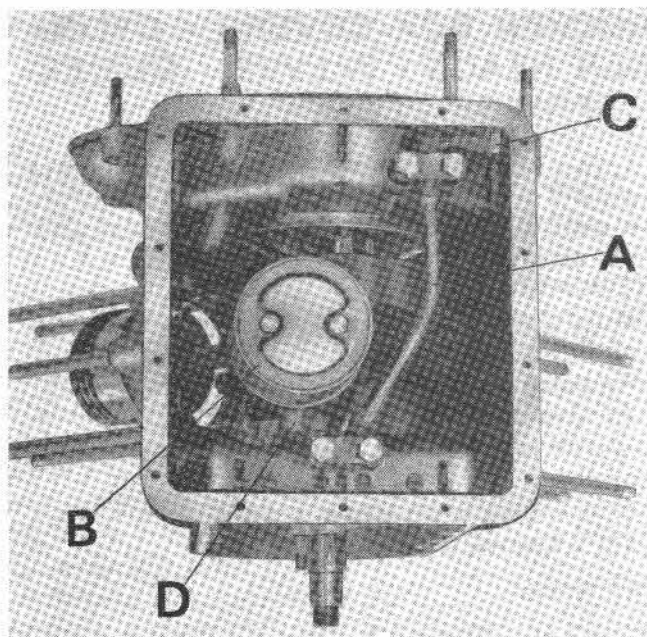

Fig. 15

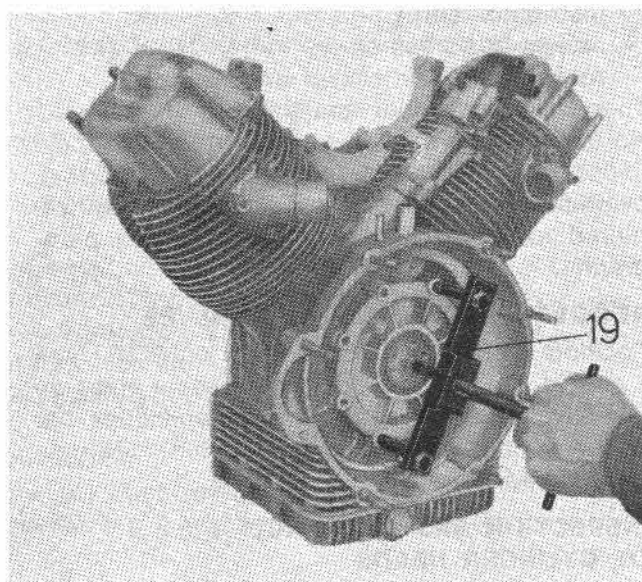

Fig. 16

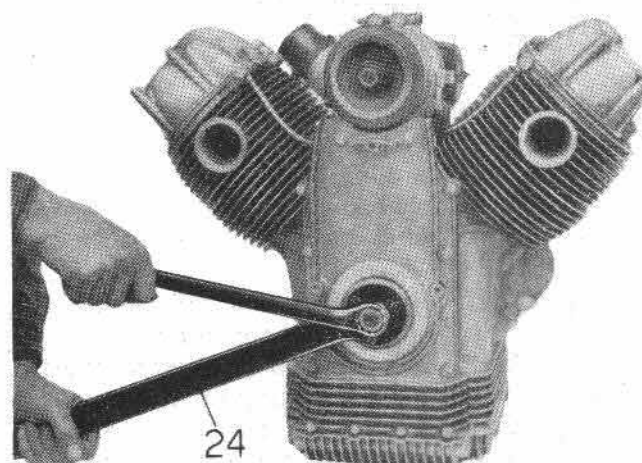

Fig. 17

ROCKER BOX COVERS - CYLINDER HEADS - VALVES - GUIDES - SPRINGS

Cylinder heads, in light alloy, are finned to increase cooling surface. Long bolts, short bolts and nuts secure cylinder heads to crankcase.

STRIPPING

Removal and stripping of cylinder heads are required when loss of compression is noticed, such loss being imputable to defective valve sealing, and also after a certain period of operation, in order to remove carbon deposits in combustion chamber.

When engine is on frame, cylinder heads stripping is carried out as follows:

Disconnect:

- sparks cables.
- air inlet tubes and carburetors.
- exhaust pipes and mufflers.
- distributor cap.
- rocker box covers.
- rocker arms and rocker arms supports.

Then remove cylinder heads.

No difficulties are involved in stripping down cylinder heads into parts. In any case all stripping, overhauling and assembling operations, and required tools, are listed in the following paragraphs:

REMOVAL OF SPRINGS AND VALVES

Position cylinder head on tool No. 60907200 (see 7 on Fig. 13) and with the arm of same press on the valve top collar so to remove semicones, top collar, spring, bottom plate and, from inside cylinder head, the valve.

INSPECTION AND OVERHAUL OF CYLINDER HEADS

Using a chamfered scraper and a wire brush remove carbon deposits and inspect valve seats.

INSPECTION AND OVERHAUL OF VALVE GUIDES

Valve guides are pressed in their housings in cylinder heads. Removal and refitting are carried out by means of a round punch (see Fig. 18 & 19). Valve guide must be replaced in case of excessive lash between its hole and the valve stem, whenever such lash is not eliminable by simply replacing valve.

After pressing guide in housing, hole must be reamed with a straight reamer in order to bring same to size as shown in coupling data chart. Negative allowance in pressing guides in their housings on cylinder heads, for both inlet and exhaust valves, is to be comprised between mm. 0.046 and 0.075 (.0018 - .00295).

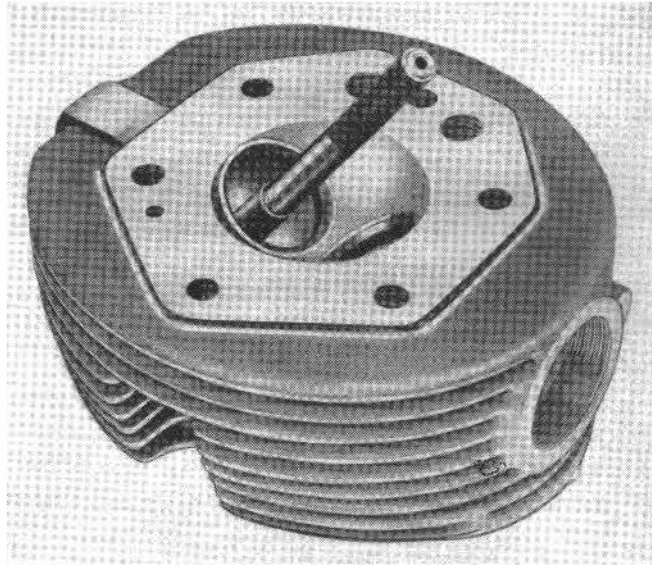

Fig. 18

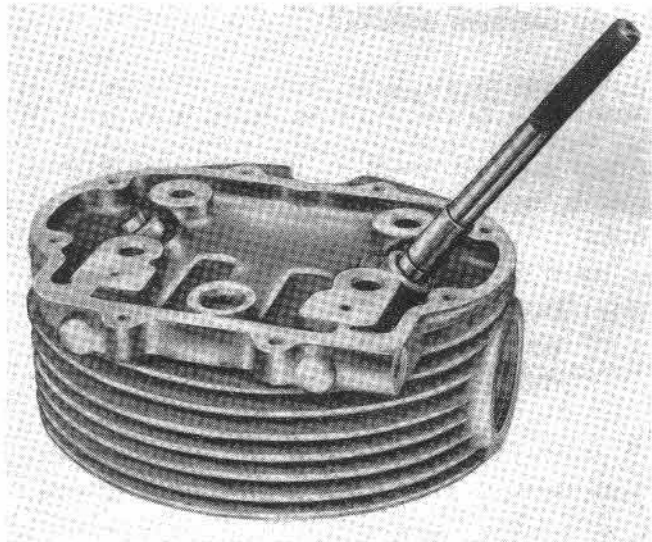

Fig. 19

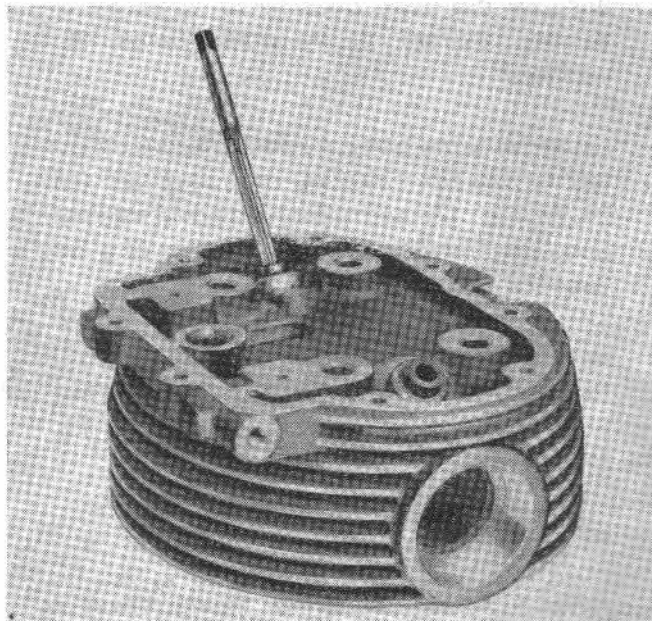

Fig. 19/1

VALVES-VALVE GUIDES COUPLING DATA

	Valve guide I.D.	Valve stem diameter	Clearances
Inlet valve	8.000 ÷ 8.022 mm. (.3149 - .3158")	7.972 ÷ 7.987 mm. (.3138 - .3144")	0.013 ÷ 0.050 mm. (.0005 - .0019")
Exhaust valve		7.965 ÷ 7.980 mm. (.3136 - .3142")	0.020 ÷ 0.057 mm. (.0008 - .0022")

INSPECTION AND OVERHAUL OF VALVE SEATS IN CYLINDER HEADS

In order to obtain a perfect match with valves, valve seats must be regrinded. Angles of inclination of the seats are as follows:

- inlet valve: 60°25'
- exhaust valve: 45°25'

Regrinding is carried out by means of a milling cutter, guided by a stem inserted in valve guide. After milling, in order to obtain a perfect match, it is necessary to grind the valve in its seat with emery paste. Should valve seats be so deteriorated that normal milling will not be sufficient, replacement of same will then be required.

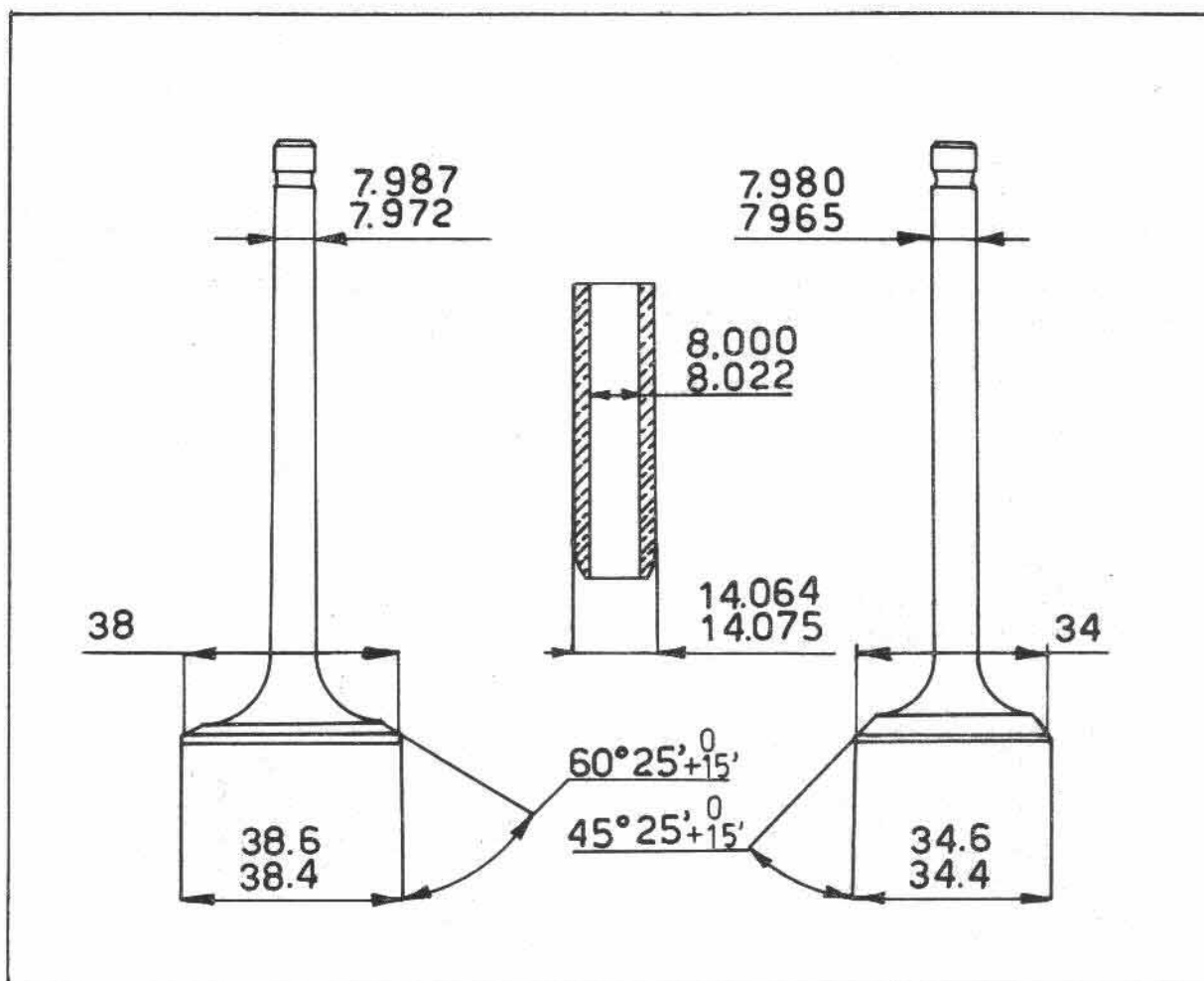

Fig. 20

INSPECTION OF VALVES

Check valves integrity and existing lash between stem and guide (for clearance refer to coupling data chart and Fig. 20). To regrind valves, insert valve stem in self-centering chuck of Universal Grinder (see Fig. 21) and adjust chuck swivel table so that valve will have an angle of inclination as follows:

— exhaust valve: $45^{\circ} 25' + \frac{0}{15}'$

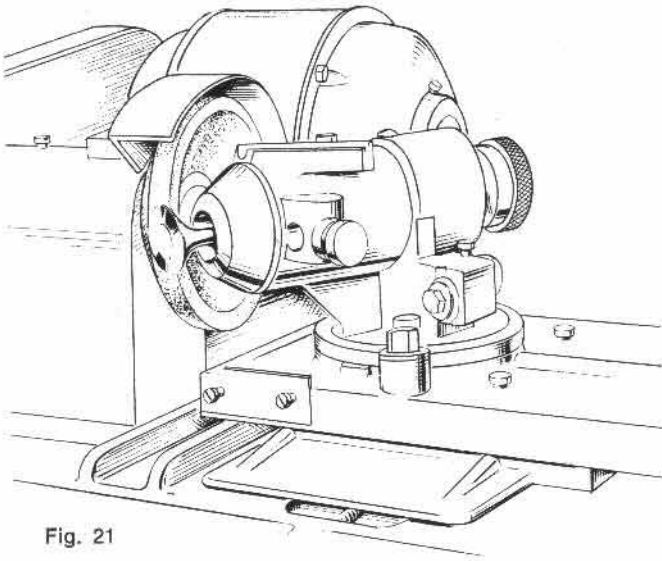

Fig. 21

— inlet valve: $60^{\circ} 25' + \frac{0}{15}'$

After grinding check thickness of valve head at max. dia. to be not less than 0.8 mm. (.0315"). Should surface at stem end show any deformation, regrind same on grinding wheel (see Fig. 22).

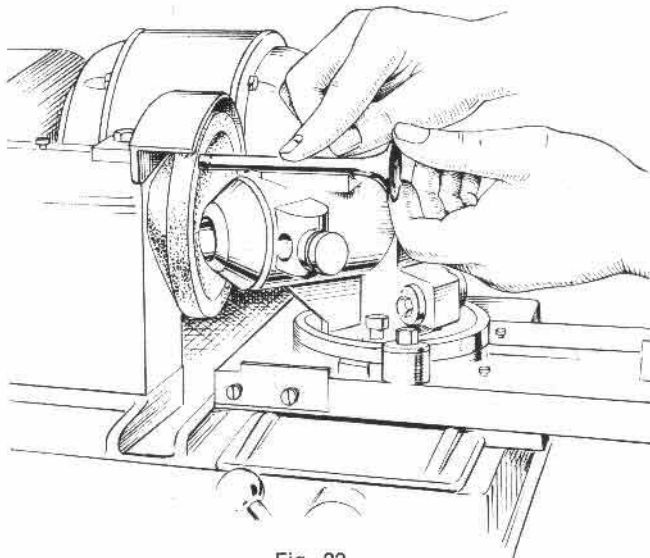

Fig. 22

Whenever regrinding valve seats, it is advisable to check that valve springs are compressed between 37 mm. and 38 mm. (1.456 - 1.496"). Adjust by adopting suitable washers at bottom collar, between spring and cylinder head.

INSPECTION OF VALVE SPRINGS

Check that valve springs are not cracked and have not lost their elasticity.

Spring, compressed at 37 mm. (1.456"), must show a load of Kg. $33 + \frac{0}{2}$ (72 lbs - 12 ozs) (closed valve position).

Spring, compressed at 28 mm. (1.024"), must show a load of Kg. $60 + \frac{0}{2}$ (132 lbs - 4 ozs) (open valve position).

Springs flexibility can be checked by suitable apparatus (see Fig. 23). As to load and deformation data refer to Fig. 24.

VALVE SEALING TEST

After reassembling valves on cylinder head, fill up inlet and exhaust ducts with gasoline. Losses, if any, will be detected by liquid leaking in combustion chamber.

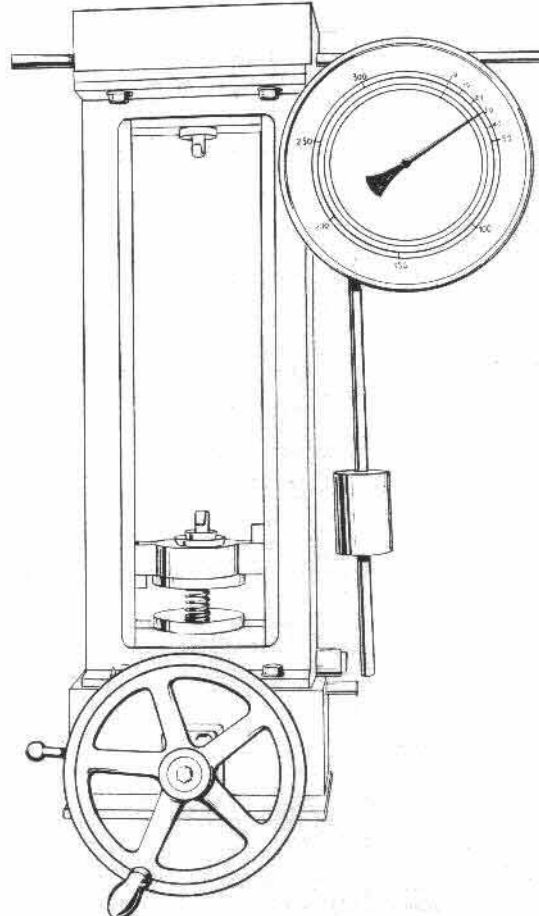

Fig. 23

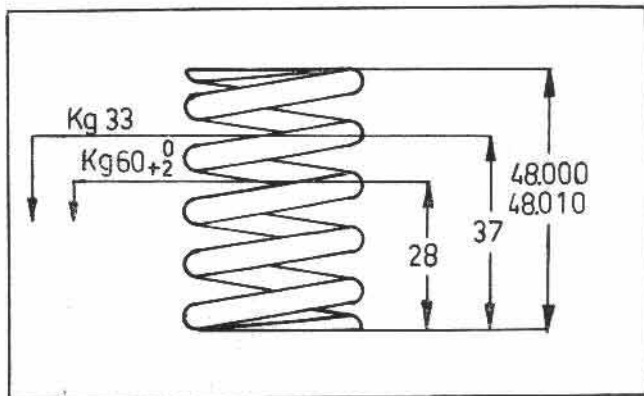

Fig. 24

ASSEMBLING OF CYLINDER HEADS ON CYLINDERS

Assembling of cylinder heads on cylinders is carried out as follows:

- reposition a new gasket between cylinder and cylinder head, making sure that lubrication openings in gasket match with lubrication holes in cylinder and cylinder head.
- secure the head assembly to the six bolts in crankcase.
- fit rocker arms support.
- position washer on cylinder bolts.
- screw down nuts on long and short bolts, in crossed sequence, without tightening. Using a torque wrench rated at Kg/m. 3.800 (27.48 ft.lb) gradually tighten long and short bolt nuts accordingly to sequence shown in Fig. 25 (1-2-3-4-5-6).

N.B.: In order to avoid deformation of cylinder heads during assembling, above instructions must be strictly followed.

ly positioned, fit on support the rocker arms c/w adjusting screw, spring and washer. After having lined them all up, by means of a

punch insert spindle and secure it to support by bolt and washer.

- fit a new gasket between cylinder head and rocker box cover.
- fit rocker box cover and screw it to cylinder head in crossed sequence.
- connect cylinder head lubricating pipe.
- insert inlet tube reducing bush on cylinder head.
- fit air inlet tube seal.
- fit air inlet tube complete with carburetor.
- fit distributor cap.
- connect sparks cable.

Repeat same assembling operations for second cylinder head.

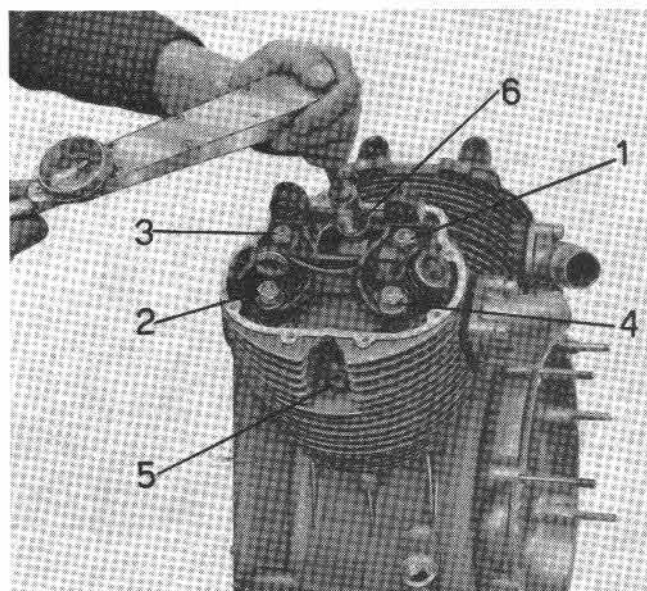

Fig. 25

CYLINDERS - PISTONS - PISTON RINGS

CYLINDERS WEAR CHECK

Measurement of internal diameter of cylinders must be taken at three different heights, both in transversal and longitudinal directions.

Dial gauge must previously be set to zero on ring gauge (see Fig. 26) and measurement chart (see Fig. 27).

Should scorings ovalization or any wear exceeding 0.10 mm. (.00394") be noticed in chrome lining (see top portion of cylinders), cylinders must then be replaced.

SELECTION OF CYLINDERS DIAMETER

Class "A"	Class "B"	Class "C"
80.000 mm. (3.14963")	80.006 mm. (3.14987")	80.012 mm. (3.15010")
80.006 mm. (3.14987")	80.012 mm. (3.15010")	80.018 mm. (3.15034")

N.B.: Cylinders must always be matched with piston of same class.

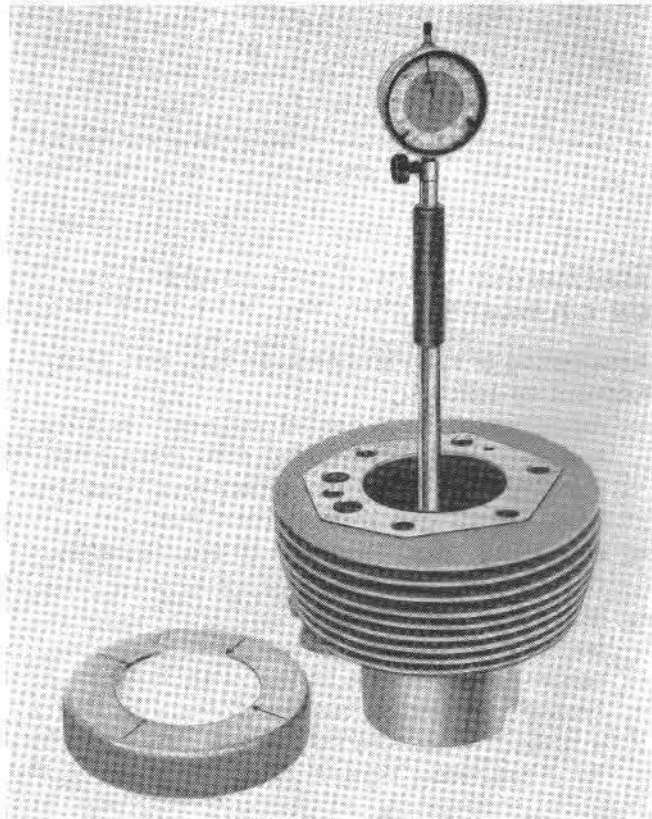

Fig. 26

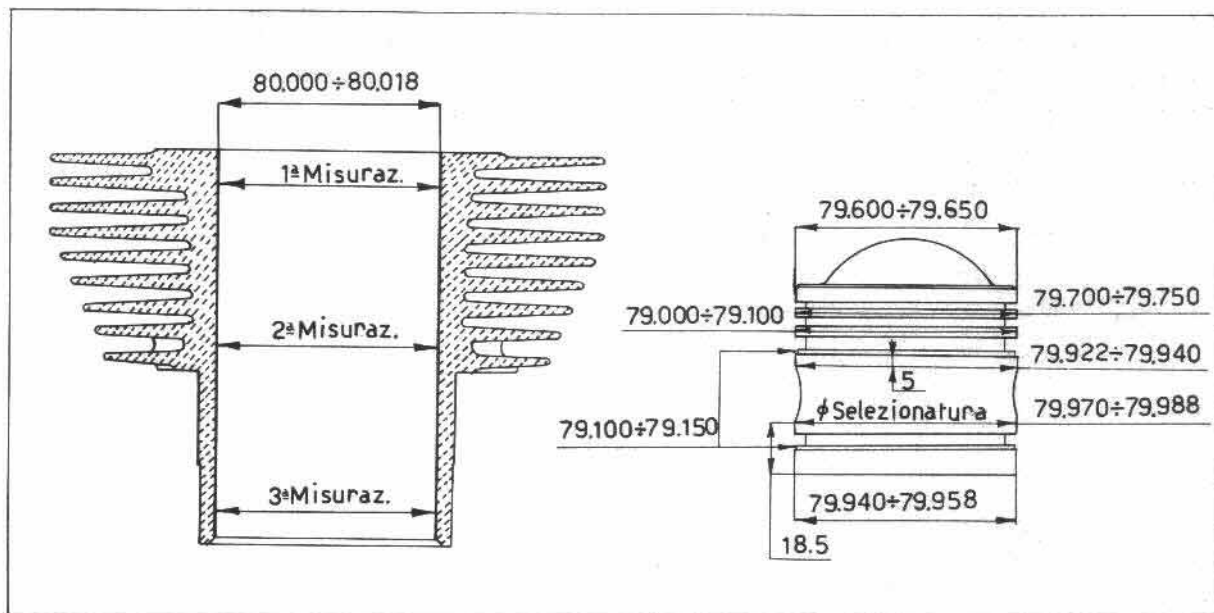

Fig. 27

PISTONS

When overhauling, decarbonize piston crowns and ring slots. Then check cylinder-piston clearance (see Fig. 28).

If clearance exceeds measurement stated by chart, then replace cylinders and pistons.

For engine balancing, both pistons must be of some weight. Maximum permissible weight difference is 1.5 grammes (23 grains) (see Fig. 29).

As to sizes refer to chart on Fig. 31.

Selection measurements shown in chart below must be taken at 18.5 mm. (.7283") from piston bottom edge, in orthogonal sense with respect to piston pin axis (see Fig. 30) ovalization shall have to be 0.055 ÷ 0.065 mm. (.0021 ÷ .0025") less than selection size.

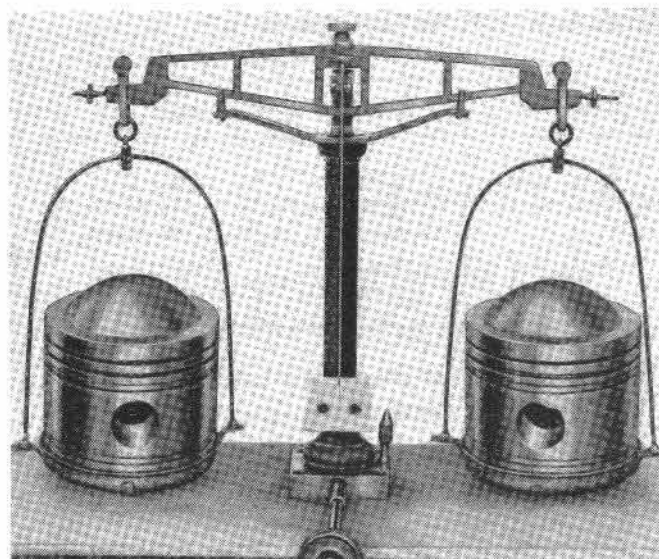

Fig. 29

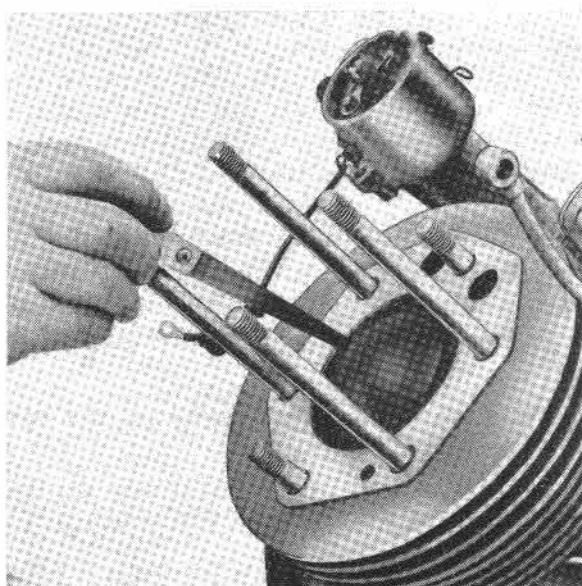

Fig. 28

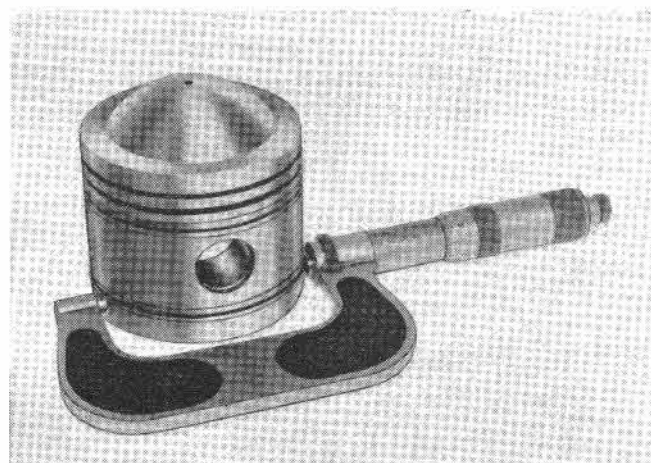

Fig. 30

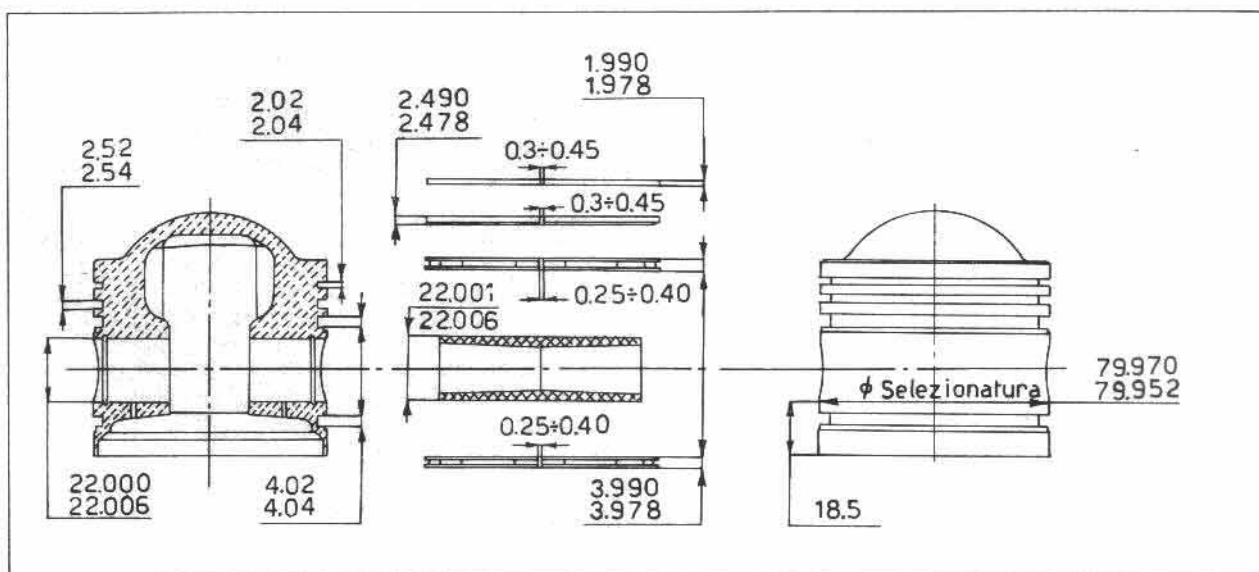

Fig. 31

SELECTION OF PISTON DIAMETER

Class "A"	Class "B"	Class "C"
79.952 mm. (3.14774")	79.958 mm. (3.14798")	79.964 mm. (3.14821")
79.958 mm. (3.14798")	79.964 mm. (3.14821")	79.970 mm. (3.14845")

N.B.: Pistons must always be matched with cylinders of same class.

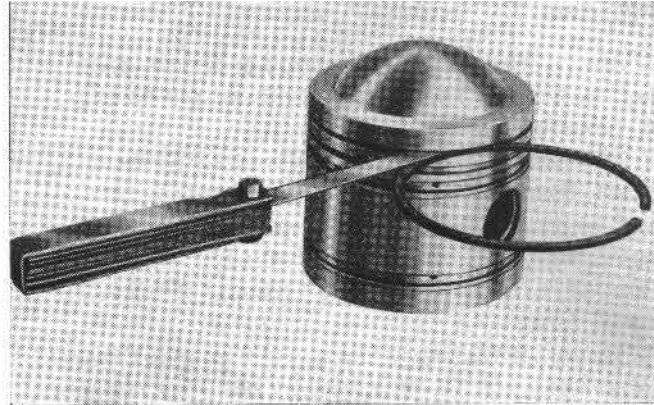

Fig. 32

PISTON RINGS AND OIL SCRAPERS

When fitting rings over piston pay attention to the position of end gap which must be placed out of line with each other.

Check clearance between rings and slots on piston (see Fig. 32). Such clearance must be within measurements shown in paragraph « Piston rings and scrapers-piston slots height clearance ».

Before fitting rings over piston, it is indispensable to insert them in cylinder and check clearance at ends (see Fig. 33) to be as shown in paragraph « Piston rings and oil scrapers end clearance ».

— Between oil scraper ends:
0.25 - 0.40 mm. (.010 - .016")

FITTING OF PISTON PINS

Before fitting pins, pistons should be heated at about 60 °C (140 °F) in order to cause a slight dilatation of the hole, thus easing introduction of pin. To fit pin use tool No. 26907100 (see 17 on Fig. 14).

Negative allowance between piston pin and hole in piston: 0.001 mm. (.00004").

PISTON RINGS AND SCRAPERS - PISTON SLOTS HEIGHT CLEARANCE

Vertical clearances:

- 1st - Piston ring
0.030 - 0.062 mm. (.001 - .0024")
- 2nd - Piston ring
0.030 - 0.062 mm. (.001 - .0024")
- 3rd - Oil scraper
0.030 - 0.062 mm. (.001 - .0024")
- 4th - Oil scraper
0.030 - 0.062 mm. (.001 - .0024")

PISTON RINGS AND OIL SCRAPER END CLEARANCE

— Between piston ring ends:
0.30 - 0.45 mm. (.012 - .018")

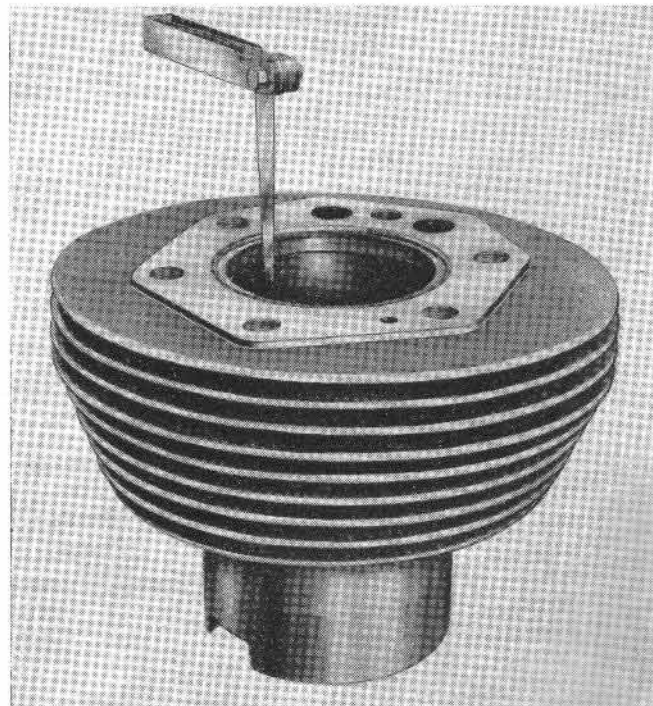

Fig. 33

CON-RODS - CRANKSHAFT - MAIN BEARING, Flywheel side - MAIN BEARING, Timing side

CON-RODS:

When overhauling con-rods, check the following:

- conditions of small end bushings and clearance between same and piston pins.
- weight of both con-rods.
- parallelism of the two axis.
- big end bearings.

Big end bearings are of thin wall type, in antifric-tion alloy, and do not allow for any adjustment. Therefore if scoring, excessive wear or seizing are detected, positive replacement must take place. When replacing bearings, crankshaft pin must be reconditioned. Before regrinding crankshaft pin, measure diameter of same at major wear point (see Fig. 44) in order to select class of o/s replacement bearing and consequently to

which diameter crankshaft pin shall have to be reground. Refer to charts « Thickness of big end bearings » and « Diameter of crankshaft pin ».

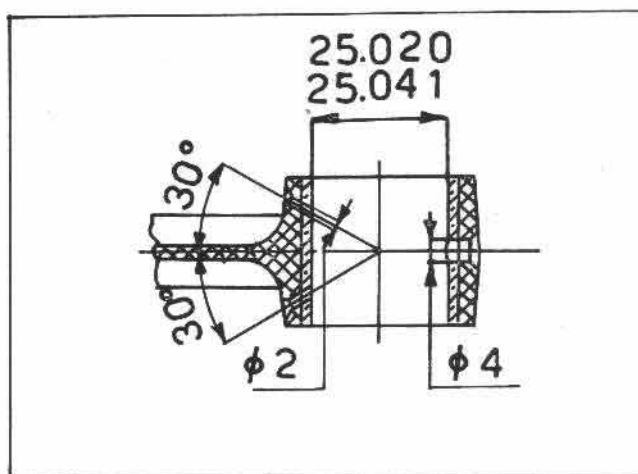

Fig. 34

THICKNESS OF BIG END BEARINGS

Original Thickness	Oversize			
	0.254 mm. (.010")	0.508 mm. (.020")	0.762 mm. (.030")	1.016 mm. (.040")
1.534 - 1.543 mm. (.06039 - .06074")	1.661 - 1.670 mm. (.06539 - .065748")	1.788 - 1.797 mm. (.07 - .07074")	1.915 - 1.924 mm. (.07539 - .07574")	2.042 - 2.051 mm. (.08039 - .08074")

DIAMETER OF CRANKSHAFT PIN

Original Diameter	Undersize			
	0.254 mm. (.010")	0.508 mm. (.020")	0.762 mm. (.030")	1.016 mm. (.040")
44.013 - 44.033 mm. 1.7334 - 1.7336")	43.759 - 43.779 mm. (1.7228 - 1.7236")	43.505 - 43.525 mm. (1.7128 - 1.7136")	43.251 - 43.271 mm. (1.7028 - 1.7036")	42.997 - 43.017 mm. (1.6928 - 1.6935")

SMALL END BUSHING

Bushing is pressed in con-rod and its internal surface must not show any seizing mark, deep scoring or excessive wear. If so, it must be replaced. Deteriorated bushing must be removed from con-rod by means of suitable round punch. After new bushing is pressed-in, the same must be drilled in correspondence with holes existing in con-rod (see Fig. 30). Inside of bushing must then be reamed to bring diameter to sizes shown in following chart (see Fig. 35).

I/D of bushing after pressing-in and reaming	Piston pin dia.
22.020 - 22.041 mm. (.8669 - .8678")	22.001 - 22.006 mm. (.8662 - .8663")
Pin-bushing clearance	
0.014 - 0.040 mm. (.0005 - .0015")	

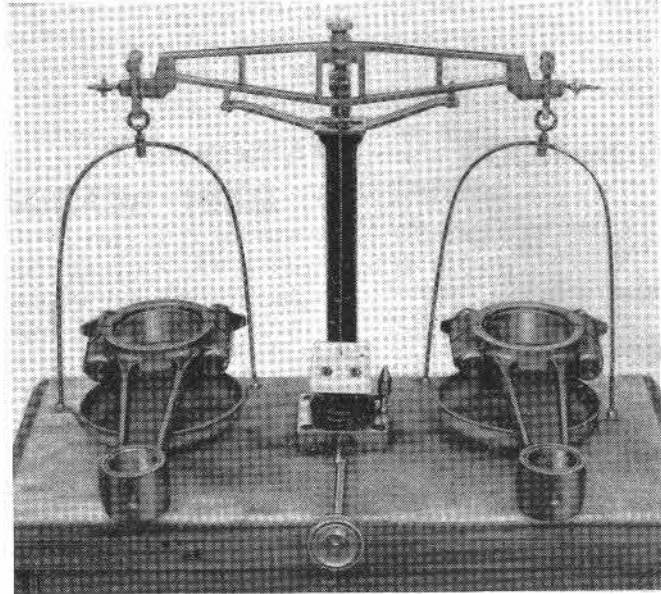

Fig. 36

Weight of complete con-rod as above: $560 + \frac{0}{10}$
grams (1 lb 3 3/4 ozs).

Maximum permissible difference: 3 grams (46 grains) (see Fig. 36).

CHECKING WEIGHT FOR ENGINE BALANCING

Con-rods, complete with small end bushing, nut, bolts and lock plates, must be of same weight.

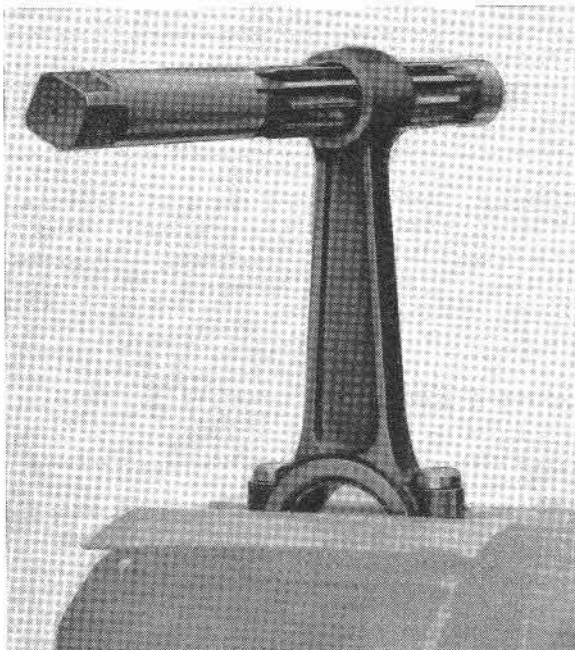

Fig. 35

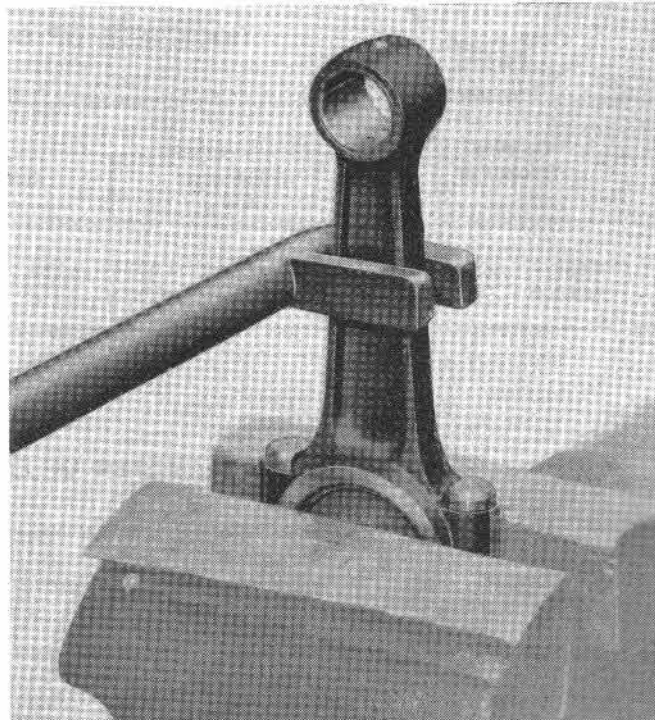

Fig. 37

CHECKING PARALLELISM OF END AXIS

Before fitting con-rods, check their « squaring », meaning that the two axis of big and small end holes must be parallel to each other. Possible deformations can be eliminated operating on rod with forked lever (see Fig. 37).

Maximum permissible offset to the two axis, measured at 200 mm. (7.874") is ± 0.03 mm. (.00118").

FITTING-UP CON-RODS ON CRANKSHAFT

When fitting up con-rods on crakshaft, pay attention that lubrication ducts in con-rod big ends are set as follows (see A on Fig. 38):

- Upward, for L/H cylinder con-rod
- Downward, for R/H cylinder con-rod

N.B.: Viewing engine from clutch side, number marked on con-rod big end must match with number marked on cap. Both numbers must be on same side (see Fig. 38).

Bearing-crankshaft pin clearance is 0.011 - 0.061 mm. (.000433 - .0024") (see Fig. 39).

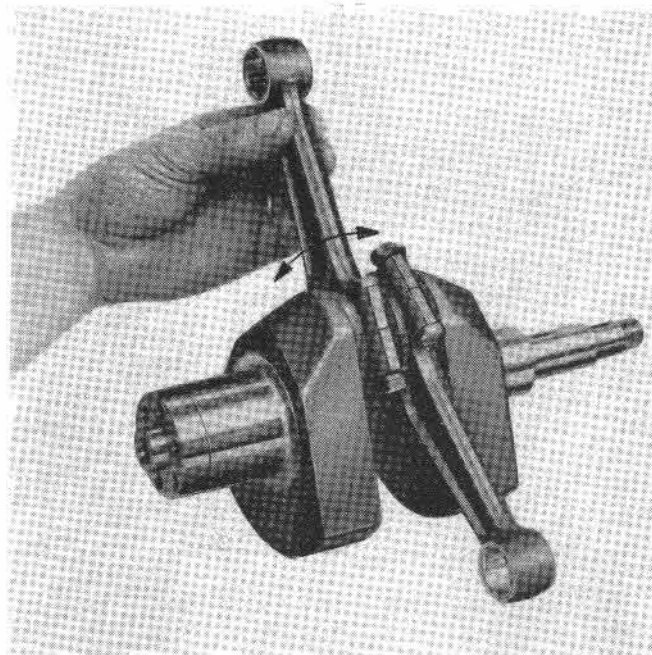

Fig. 39

Con-rod-crankshaft side clearance must be 0.3 - 0.5 mm. (.0118-.0196") (see Fig. 40).

Fit con-rods on crankshaft and tighten nuts by means of torque wrench at 3.500 Kg/m. (25.31 ft.lbs.). See Fig. 41 Fig 42 shows dismantled con-rod assembly. As to measurements, refer to Fig. 43.

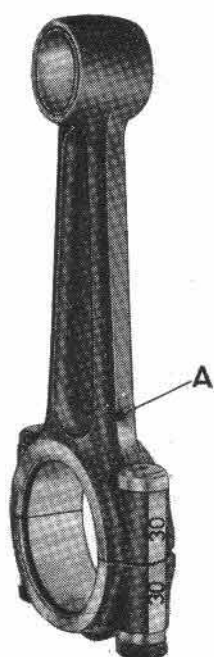

Fig. 38

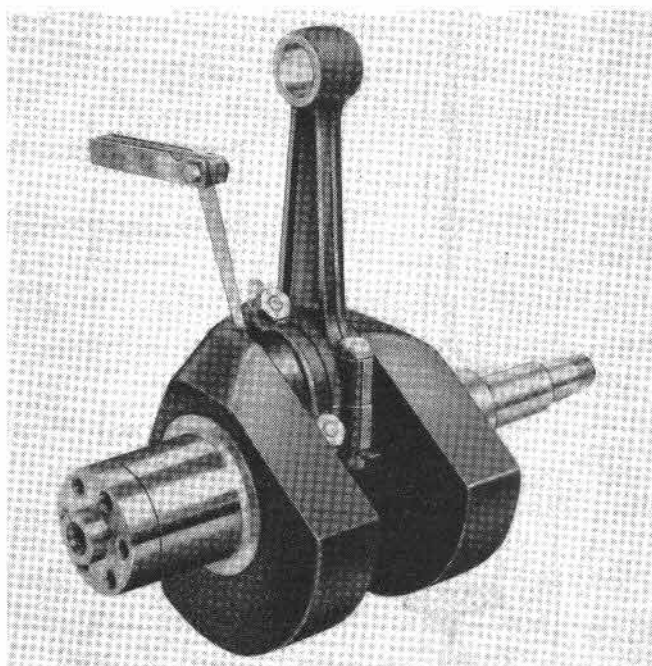

Fig. 40

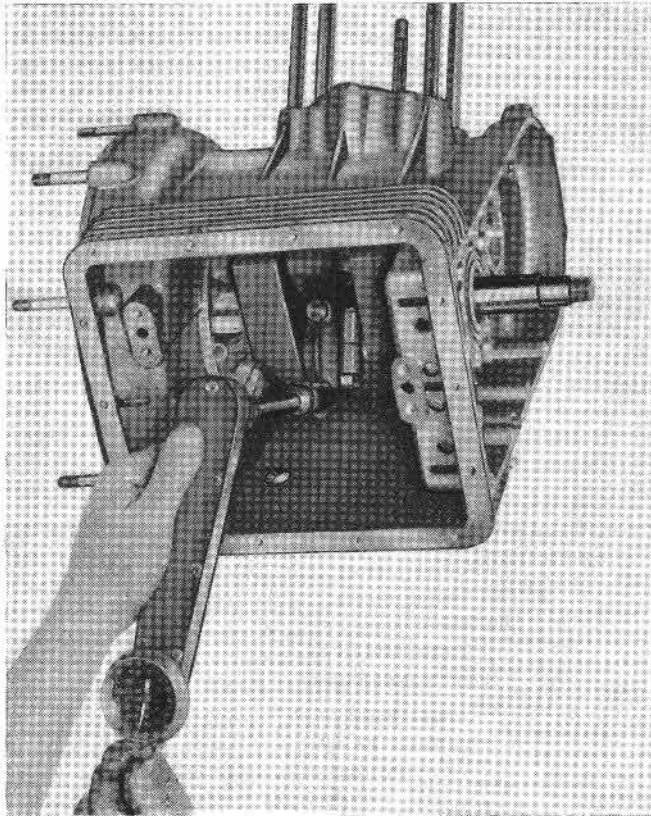

Fig. 41

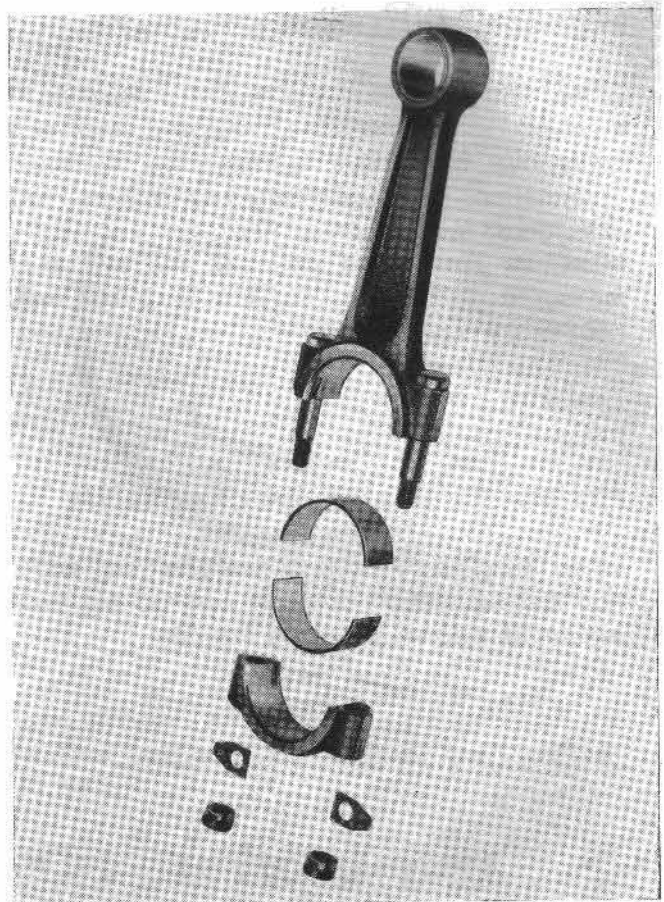

Fig. 42

→

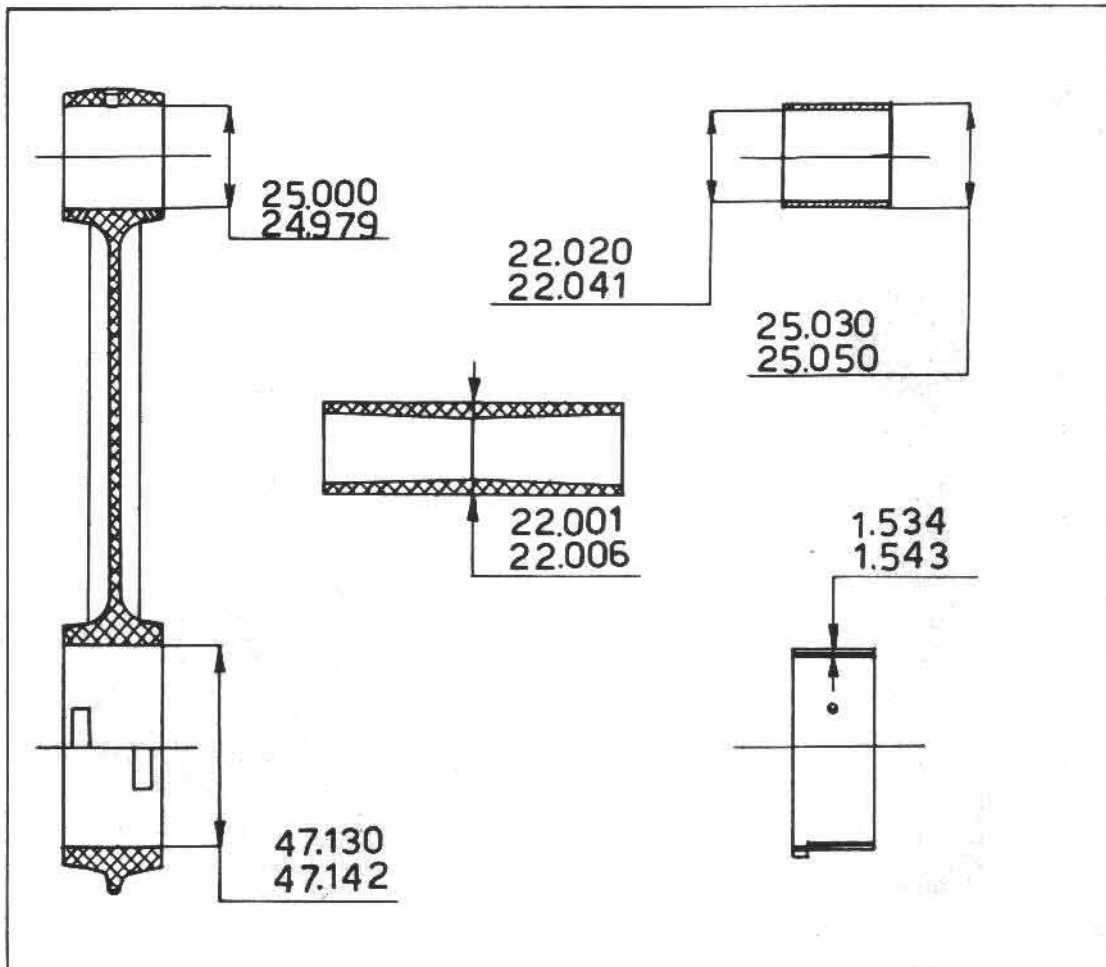

Fig. 43

CRANKSHAFT

Crankshaft of steel construction, on two special main bearings, with suitably counterweighted crank.

Check crank-pin and main shafts. If slight seizing marks are detected, they can be eliminated using very fine carborundum, but should surfaces show deep scorings or remarkable ovalization, the regrinding must take place and o/s bearings or bushings be adopted. Main bearings under-size range is the following: 0.2 mm. (.00787") - 0.4 mm. (.01574") - 0.6 mm. (.02362") - 0,8 mm. (.03149").

Spare main bearings are always meant to be c/w flange. Crankpin bearings under-size range is the following: 0.254 mm. (.010") - 0.508 mm. (.020") - 0.762 mm. (.030") - 1.016 mm. (.040").

As previously said, before regrinding crank-pin and main shafts carefully measure them at major wear point (see Fig. 44-45-46-47) in order to decide new diameter taking into account under-size ranges and necessary clearances.

Clearances are the following:

- Mainshaft-bearing, timing side: 0.025 - 0.057 mm. (.00098 - .00224")

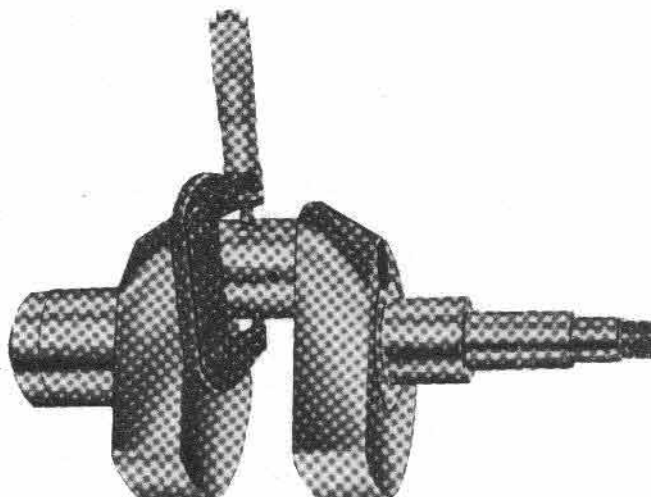

Fig. 44

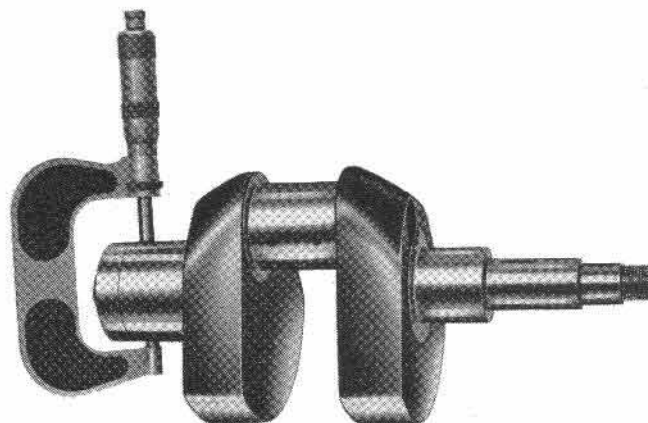

Fig. 45

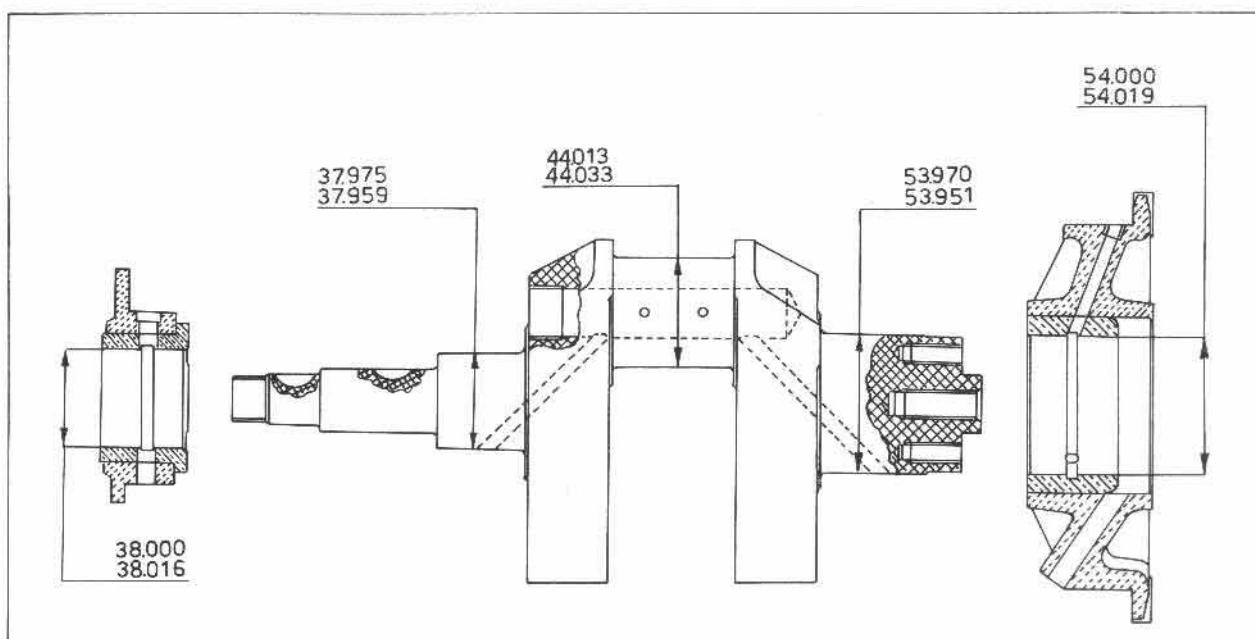

Fig. 46

- Mainshaft-bearing, flywheel side: 0.030 - 0.068 mm. (.00118 - .0027")
- Crankpin-bearing: 0.011 - 0.061 mm. (.0004 - .0024")

Static balancing of crankshaft is obtained by applying a weight of Kg. 1.586 ± .015 on crankpin (3.1/2 lbs.).

When regrinding, restore shoulder relief radiuses, which are 1.5 mm. (.059") for crankpin and 3 mm. (.118") for mainshaft, flywheel side.

Fig. 47

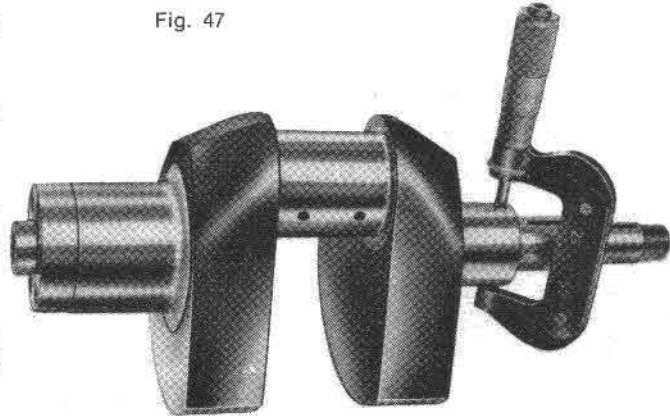

DIAMETER OF MAINSHAFT, FLYWHEEL SIDE

Original diameter	Undersize			
	0.2 mm. (.00787")	0.4 mm. (.01574")	0.6 mm. (.02362")	0.8 mm. (.03149")
53.970 mm. (2.1248")	53.770 mm. (2.1169")	53.570 mm. (2.1090")	53.370 mm. (2.1013")	53.170 mm. (2.093")
53.931 mm. (2.1233")	53.751 mm. (2.1162")	53.551 mm. (2.1033")	53.351 mm. (2.1004")	53.151 mm. (2.0926")

DIAMETER OF MAINSHAFT, TIMING SIDE

Original diameter	Undersize			
	0.2 mm. (.00787")	0.4 mm. (.01574")	0.6 mm. (.02362")	0.8 mm. (.03149")
37.975 mm. (1.4951")	37.775 mm. (1.4872")	37.575 mm. (1.4793")	37.375 mm. (1.4715")	37.175 mm. (1.4636")
37.959 mm. (1.4944")	37.759 mm. (1.4866")	37.559 mm. (1.4787")	37.359 mm. (1.4707")	37.159 mm. (1.4629")

I/D OF MAIN BEARING, FLYWHEEL SIDE

Original diameter	Undersize			
	0.2 mm. (.00787")	0.4 mm. (.01574")	0.6 mm. (.02362")	0.8 mm. (.03149")
54.000 mm. (2.1260")	53.800 mm. (2.1171")	53.600 mm. (2.1102")	53.400 mm. (2.1024")	53.200 mm. (2.0945")
54.019 mm. (2.1267")	53.819 mm. (2.1188")	53.619 mm. (2.1109")	53.419 mm. (2.1031")	53.219 mm. (2.0952")

I/D OF MAIN BEARING, TIMING SIDE

Original diameter	Undersize			
	0.2 mm. (.00787")	0.4 mm. (.01574")	0.6 mm. (.02362")	0.8 mm. (.03149")
38.000 mm. (1.4961")	37.800 mm. (1.4883")	37.600 mm. (1.4803")	37.400 mm. (1.4725")	37.200 mm. (1.5646")
38.016 mm. (1.4967")	37.816 mm. (1.4889")	37.616 mm. (1.4809")	37.416 mm. (1.4731")	37.216 mm. (1.5652")

FLYWHEEL SIDE FLANGE COMPLETE WITH MAIN BEARING

Check that surfaces contacting crankcase are smooth and do not show deep scoring, also check that main bearing size is as stated in chart « I/D of main bearing, flywheel side ». Make sure that lubrication ducts in flange match with those in crankcase and assemble using tool No. 12912000 (see 12 on Fig. 48). This tool will allow an easy fitting over seal ring (inserted in flange) on crankshaft, without damaging internal edge of seal ring.

SEAL RING FOR FLYWHEEL SIDE FLANGE

When overhauling, check that seal ring is properly inserted in flange housing and that internal surface of ring contacting crankshaft is not damaged or crumbled. If so, replace seal ring.

TIMING SIDE FLANGE COMPLETE WITH MAIN BEARING

Check that surfaces contacting crankcase are smooth and do not show deep scorings. Also check that main bearing size is as stated in chart « I/D of main bearing, timing side ».

TIMING COVER

Check that surface contacting crankcase is smooth without deep scorings. Fitting cover c/w seal ring on crankcase, use tool No. 12908300 (see 22 on Fig. 49). This tool will allow an easy fit over seal ring on crankshaft, without damaging internal edge of seal ring.

TIMING COVER SEAL RING

When overhauling, check that seal ring is properly inserted in cover housing and that internal surface of ring contacting crankshaft is not damaged or crumbled. If so replace seal ring.

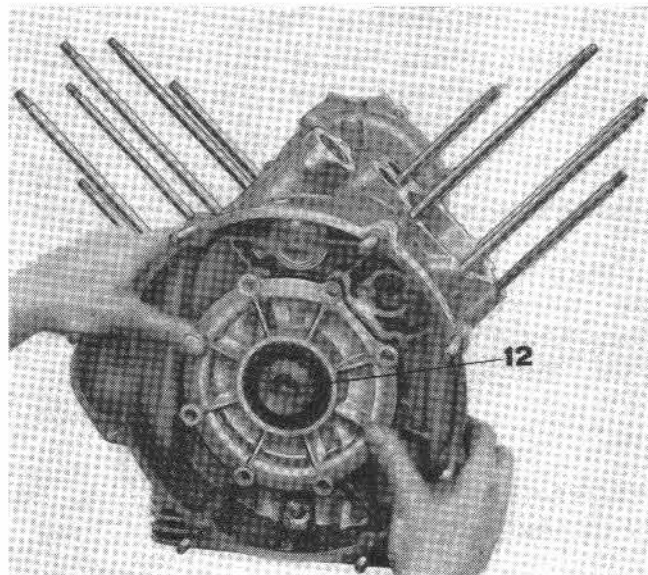

Fig. 48

CRANKCASE

Light alloy casting, suitably ribbed. Crankcase includes:

- Main shaft bearing housing.
- Tappet guides.
- Cylinders housings.
- Gearbox coupling flange.

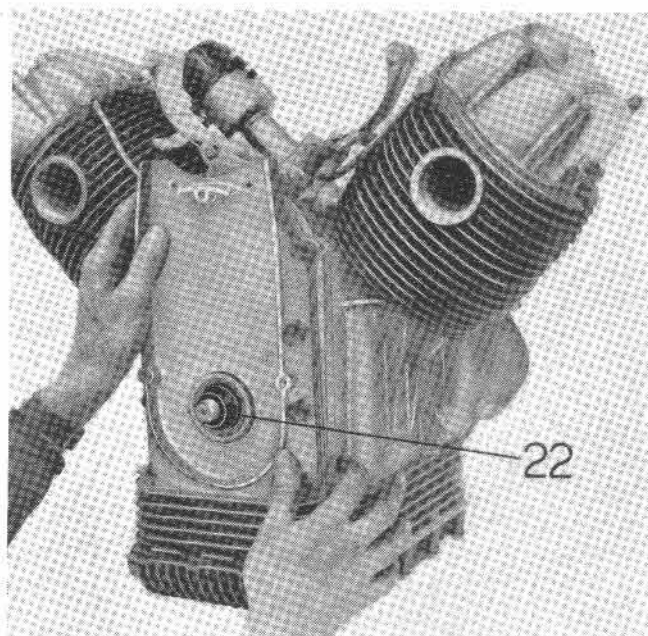

Fig. 49

- Timing cover coupling flange.
- External bosses, flanges and various housings for accessories fitting.

INSPECTION AND OVERHAUL OF CRANKCASE

Check that contact surfaces between crankcase, main bearing flanges, tappet guides, gearbox coupling flange and timing cover flange are unimpaired without any scoring.

WEAR CHECK OF TAPPET GUIDES IN CRANKCASE

Check correct clearance (see chart « Coupling data of tappets and guides in crankcase » in « TIMING DATA » chapter). If necessary, guides must be reamed (see Fig. 50) using reamer of 1st or 2nd oversize as shown above in chart. Oversize tappets are also available.

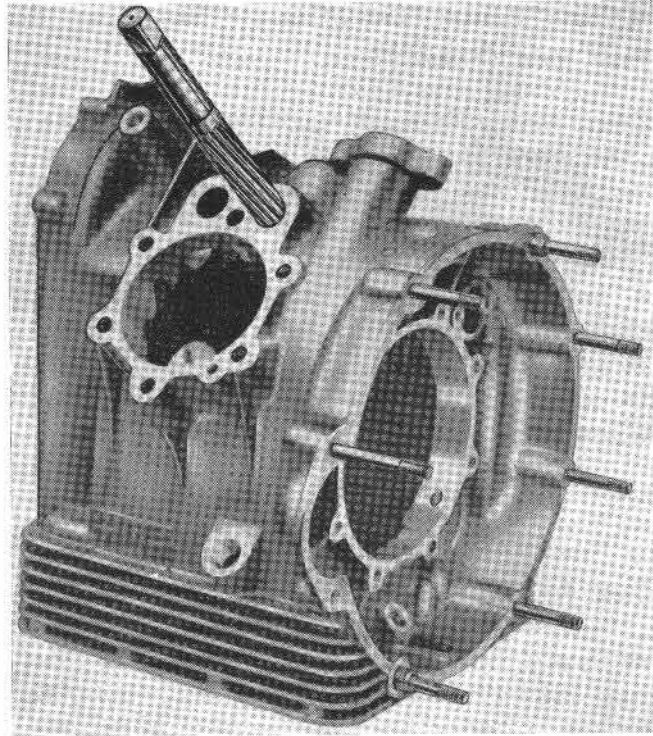

Fig. 50

SUMMING UP OF DATA PERTAINING TO CRANK MECHANISM PARTS (Manufacturing measures)

Cylinder barrel dia.:	80.000 - 80.018 mm. (3.1496 - 3.1503")
Piston diameters:	
— at piston top	79.600 - 79.650 mm. (3.1338 - 3.1358")
— below top ring	79.700 - 79.750 mm. (3.1378 - 3.1397")
— below 2nd ring	79.000 - 79.100 mm. (3.1102 - 3.1141")
— at recesses below oil scrapers	79.100 - 79.150 mm. (3.1149 - 3.1161")
— 5 mm. (.196") below top oil scraper recess	79.922 - 79.940 mm. (3.1465 - 3.1472")
— selection dia. at 18.5 mm. (.728") over piston bottom edge	79.952 - 79.970 mm. (3.1477 - 3.1484")
— at piston bottom	79.922 - 79.940 mm. (3.1465 - 3.1472")
— piston pin housing dia.	22.000 - 22.006 mm. (.8661 - .8663")
Piston pin dia.	22.001 - 22.006 mm. (.86614 - .86634")
Main shaft dia., flywheel side	53.970 - 53.951 mm. (2.1248 - 2.1240")
Main shaft dia., timing side	37.975 - 37.959 mm. (1.4951 - 1.4944")
I/D of main bearings c/w flange:	
— flywheel side	54.000 - 54.019 mm. (2.1260 - 2.1268")
— timing side	38.000 - 38.016 mm. (1.4961 - 1.4967")
Undersize range of main bearings available (see chart on page 27) as spare parts: 0.2 mm. (.00787") - 0.4 mm. (.01574") - 0.6 mm. (.02362") - 0.8 mm. (.03149")	
Crankpin dia.	44.013 - 44.033 mm. (1.7328 - 1.7336")
Dia. of con-rod big end bearing housing	47.130 - 47.142 mm. (1.9016 - 1.8559")
Original thickness of con-rod bearings	1.534 - 1.543 mm. (.06039 - .06070")
Oversize range of big end bearings (see chart on page 23) 0.254 mm. (.010") - 0.508 mm. (.020") - 0.762 mm. (.030") - 1.016 mm. (.040")	
I/D of small end bushing (after pressing in):	22.020 - 22.041 mm. (.8669 - .8677")

TIMING DATA

Timing data (rocker clearance for valve timing 0.5 mm. (.0196")) are the following (see Fig. 51):

INLET:

- opens 24° before T.D.C.
- closes 58° after B.D.C.

EXHAUST

- opens 58° before B.D.C.
- closes 22° after T.D.C.

Normal rocker clearance, in COLD engine:

- 0.10 mm. (.0039") to inlet
- 0.20 mm. (.0078") to exhaust

CAMSHAFT

Camshaft is of steel construction (see Fig. 52), located in crankcase and supported at ends in suitable housings directly in crankcase. Camshaft is gear driven by crankshaft. Valves are

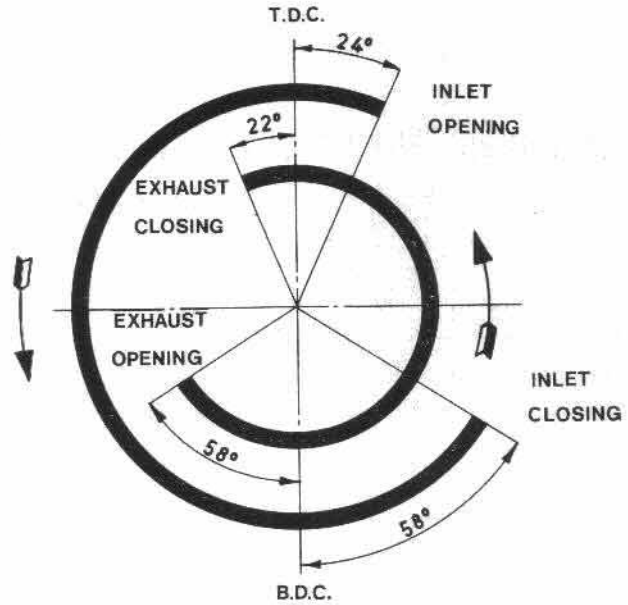

Fig. 51

operated through tappets, push rods and rockers. Suitable tappet guides machined directly in crankcase.

DIAMETER OF CAMSHAFT JOURNALS AND THEIR HOUSING IN CRANKCASE

	camshaft journals dia.	housing in crankcase dia.	fitting clearance
Timing side	46.975 - 47.000 mm. (1.8494 - 1.8504")	47.025 - 47.064 mm. (1.8511 - 1.8529")	0.025 - 0.089 mm. (.0009 - .0035")
Flywheel side	31.975 - 32.000 mm. (1.2588 - 1.2598")	32.025 - 32.064 mm. (1.2607 - 1.2623")	0.025 - 0.089 mm. (.0009 - .0035")

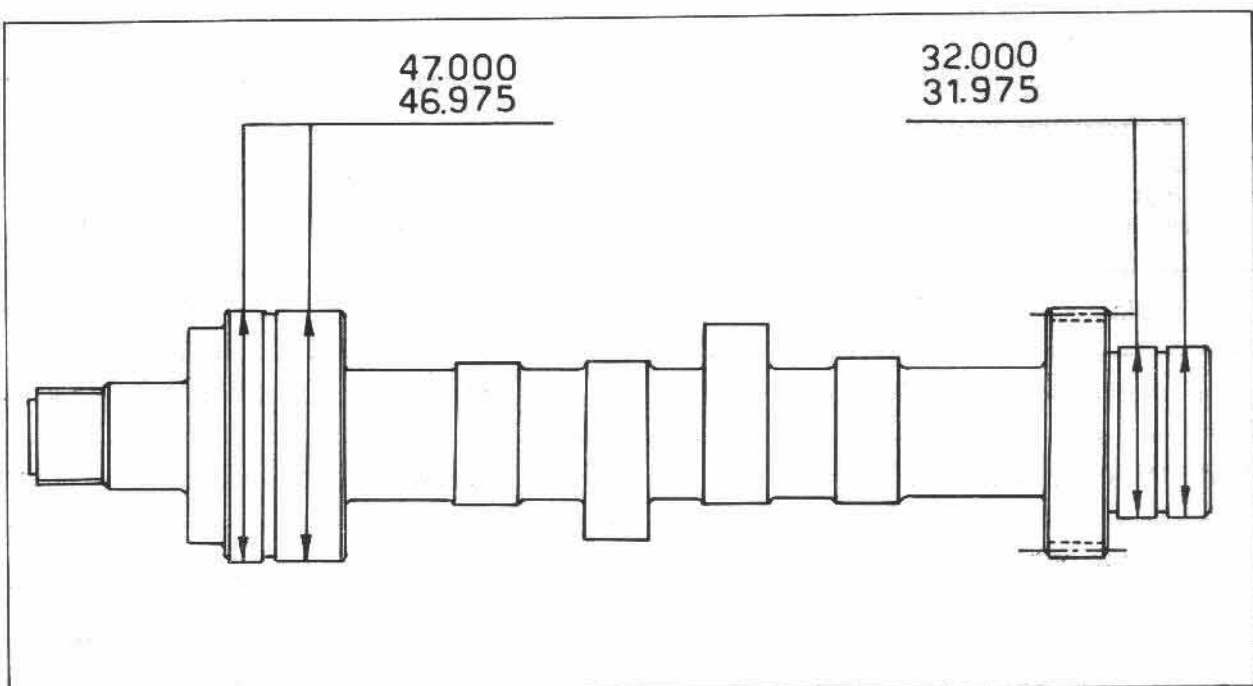

Fig. 52

CHECKS

Surfaces of cams and camshaft journals must be very smooth and in perfect condition. Should they show any scoring or sizing marks, it is advisable to replace camshaft. Nevertheless if imperfections are slight, eliminate them using very fine carborundum. Fitting clearances between journals and housings in crankcase are shown on above chart.

TAPPETS

To check tappets and their guides in crankcase, refer to Fig. 53 and chart here below. Always check that surface of tappet contacting cam is perfectly smooth. Eliminate possible slight wear marks or roughness with fine carborundum. Check that tappets guides have no scoring. Assembling data and oversizes are shown in chart below.

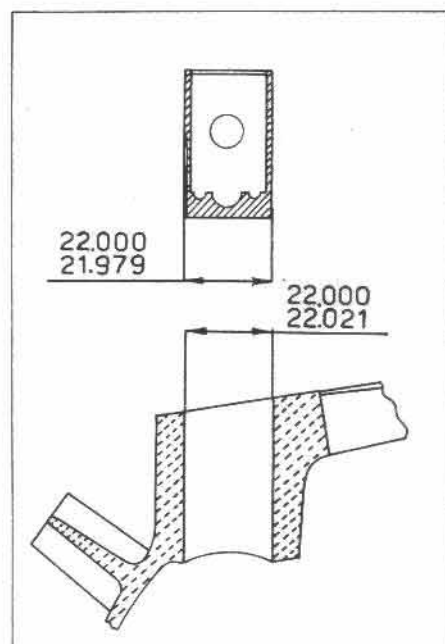

Fig. 53

COUPLING DATA OF TAPPETS AND GUIDES IN CRANKCASE

	I/D of guides	O/D of tappets	fitting clearance
Original	22.021 - 22.000 mm. (.8669 - .8661")	22.000 - 21.979 mm. (.8661 - .9046")	0 - 0.042 mm. (0 - .0016")
Oversize 0.05 mm. (.0019)	22.071 - 22.050 mm. (.8688 - .8680")	22.050 - 22.029 mm. (.8680 - .8672")	0 - 0.042 mm. (0 - .0016")
0.10 mm. (.0039)	22.121 - 22.100 mm. (.8708 - .8700")	22.100 - 22.079 mm. (.8700 - .8692")	0 - 0.042 mm. (0 - .0016")

PUSH RODS

Push rods must not show any deformation, and contact surfaces at ends must be without seizing

marks or roughness, otherwise they must be replaced.

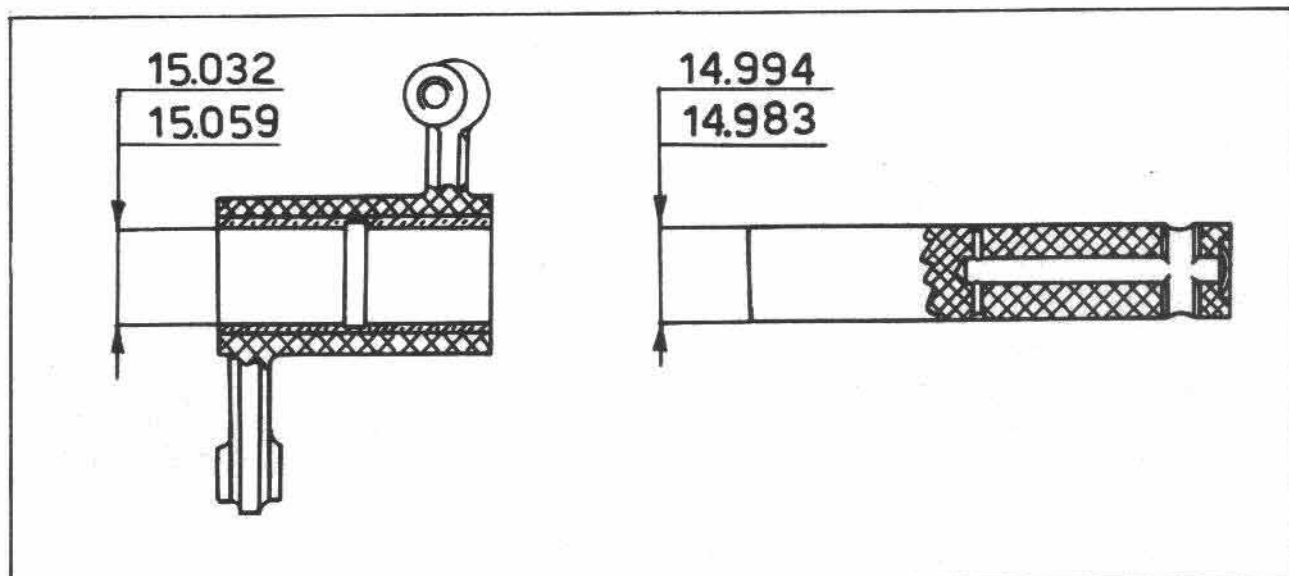

Fig. 53/1

ROCKERS

When overhauling, check clearance between rocker arms and spindles (see Fig. 53/1 and chart below). If necessary, replace the more

worn out part, or even both of them. Besides clearance also check that contact surfaces are without scoring or seizing marks, otherwise replace part.

COUPLING DATA OF ROCKER ARMS AND SPINDLES

I/D of rocker arm bushing (after pressing-in and machining)	Diameter of rocker arm spindle	Fitting clearance
15.032 - 15.059 mm. (.5918 - .5929")	14.983 - 14.994 mm. (.5899 - .5903")	0.038 - 0.076 mm. (.0015 - .0029")

Contact surfaces must be mirror polished.

TAPPET CLEARANCE ADJUSTMENT

Great care must be taken when adjusting tappet clearance, in order to avoid alterations to timing diagram. Excessive clearance will cause noisy valve operation, while absence of clearance will prevent complete valves closing, thus damaging same and their seats. Adjustment is made as shown on Fig. 54, operating as follows:

- with COLD ENGINE, undo nut (A) and screw in or out screw (B), bearing in mind that correct clearances are 0.1 mm. (.0039") to inlet valve and 0.2 mm. (.0078") to exhaust valve. Check clearance with a feeler gauge as shown on Fig. 54.

VALVE TIMING

For a start, give to tappets a provisional clearance of 0.5 mm. (.0195"). Rotate flywheel until mark

on same matches with mark on crankcase on cylinder No. 2 side (L/H viewing engine from clutch side). In absence of mark, refer to center of jut on crankcase flange (see A on Fig. 55). Piston is now at T.D.C., both valves are closed and cylinder is at compression stroke end.

Apply to flywheel a degree plate, so that zero points to arrow on flywheel (see A on Fig. 55) and rotate flywheel of 122° in engine rotation direction (see B on Fig. 55). Exhaust valve of cylinder No. 2 (L/H) is now beginning to open.

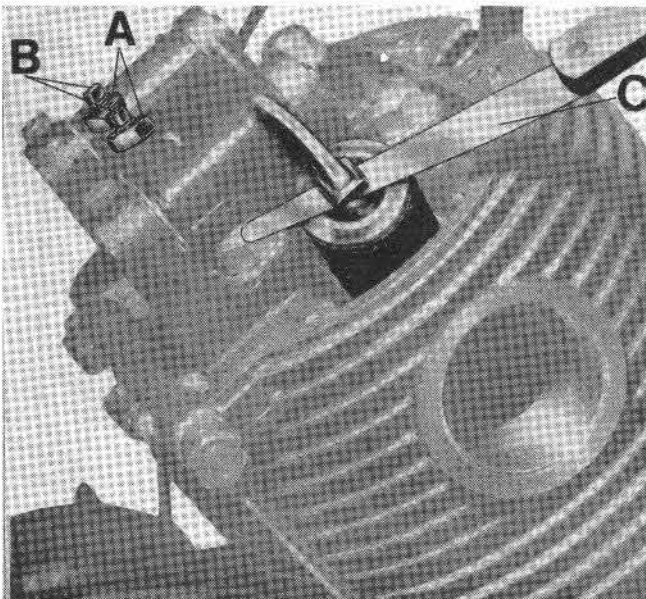

Fig. 54

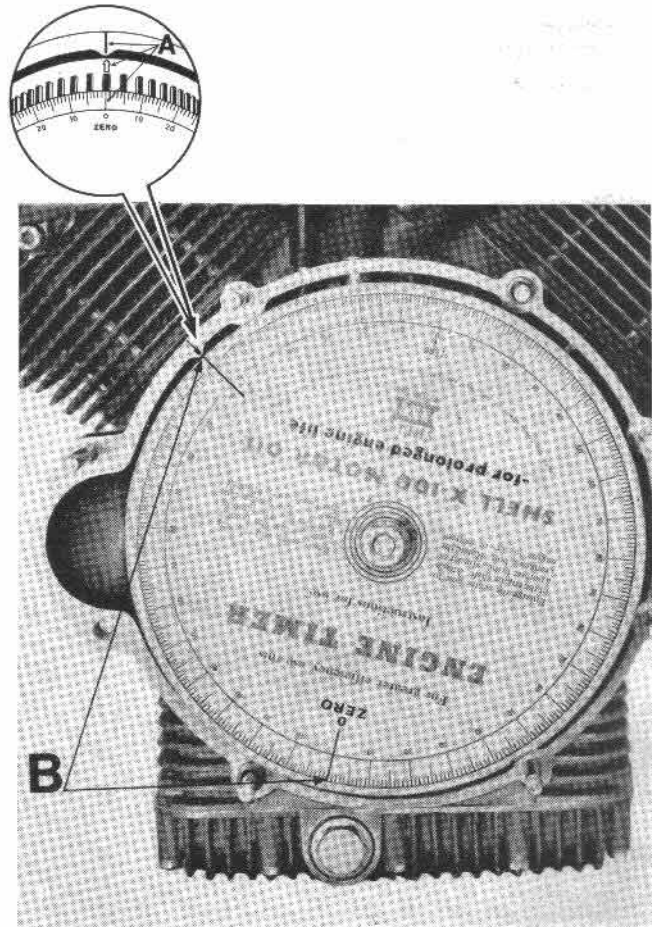

Fig. 55

Fit distribution gear on crankshaft and using a screwdriver rotate camshaft CCW until rocker arm touches exhaust valve in cylinder head No. 2 (L/H). Now fit cam wheel on camshaft, locating the best position to make slots in wheel to match with slots in camshaft, thus making possible to insert dowel without moving crankshaft and camshaft either.

At the end of the above operation mark the two teeth of cam wheel, the tooth of distribution gear engaging same and also mark the slot in cam wheel in which the dowel is inserted (see A and B on Fig. 57). Now, checking opening and closing of inlet and exhaust valves by suitable degree plate, timing data should be as shown in diagram on Fig. 51.

Still on COLD ENGINE make the final adjustment of tappet clearance. Correct clearance is 0.10 mm. (.0039") to inlet and 0.20 mm. (.0078") to exhaust.

Fig. 56 shows details of tappets, rocker arms, springs, collars, semicones and valves.

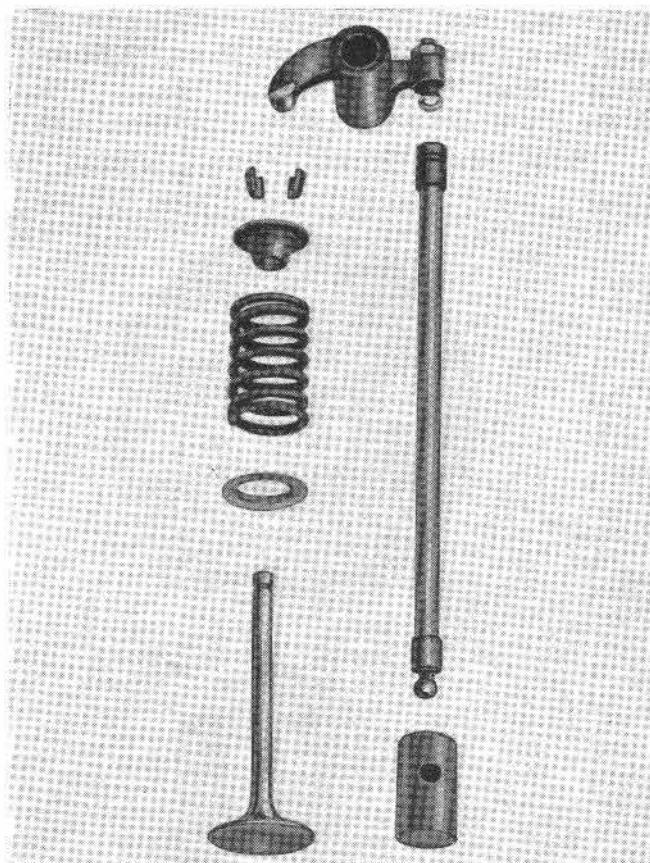

Fig. 56

N.B.: When carrying out replacement of distribution gear and cam wheel without removing engine from frame and consequent valve timing is needed, a suitable special tool has been provided for the purpose. This tool enables to transfer exactly the reference marks from old wheel and gear onto the new ones. Use it as follows:

To mark the equivalent tooth of the new distribution gear, just count exact number of teeth from keyway.

After marking teeth and dowel slot on new cam

- remove gear and wheel to be replaced.
- insert dowel of tool No. 12913800 (see 25 on Fig. 58) in marked cam wheel slot (the same in which camshaft dowel was previously located).
- undo bolt (A) of above tool and rotate tool arm (B) until notch at end of same comprises perfectly the two marked teeth. Then screw down bolt (A).
- remove tool from wheel to be replaced and apply it to new wheel. Insert tool dowel in each of the five slots until notch at arm's end (B) will comprise perfectly **two teeth** of the new wheel. Now mark with paint the two teeth comprised in arm notch and the slot in which the tool dowel is inserted.

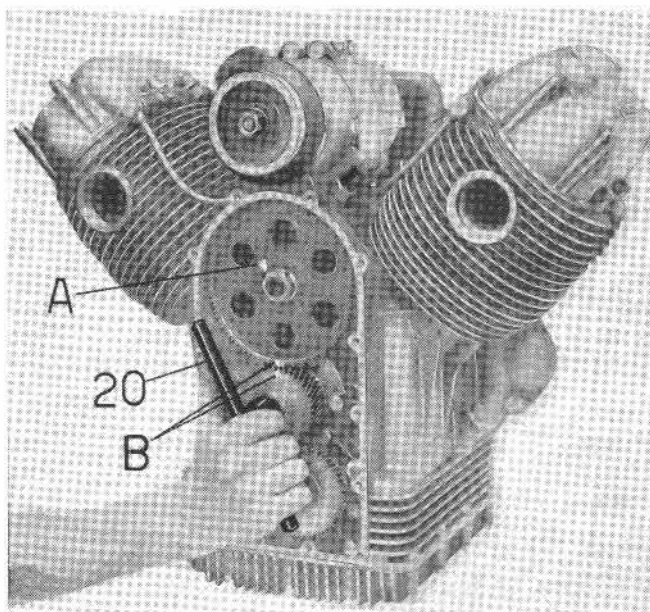

Fig. 57

wheel and tooth on new distribution gear, fit gear on crankshaft and wheel on camshaft, inserting dowel in marked slot.
At the end of above operations, rotate crankshaft

using special wrench No. 12912900 (see 20 on Fig. 57) and check if marked tooth on distribution gear engages the two marked teeth of cam wheel.

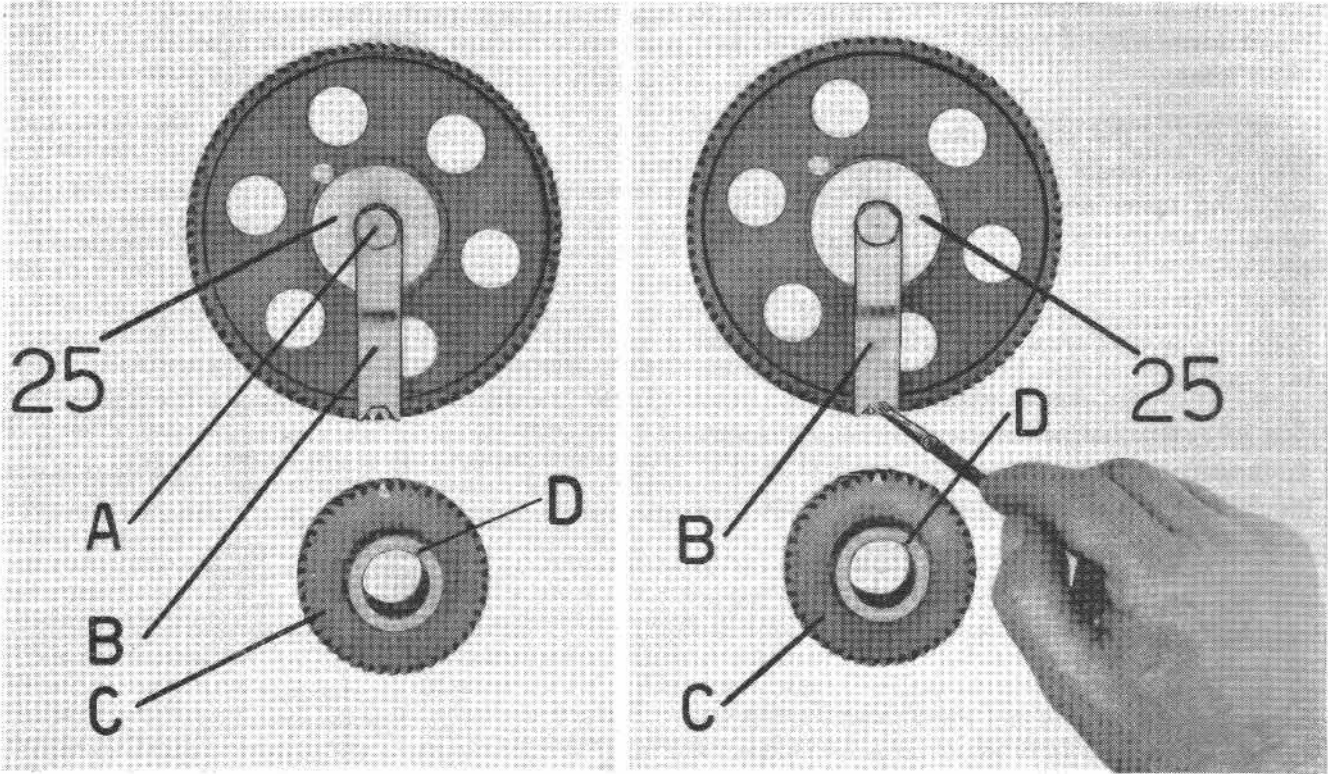

Fig. 58

SUMMING UP OF DATA PERTAINING TO TIMING PARTS (manufacturing measures)

I/D of camshaft housings in crankcase	
— timing side	47.025 - 47.064 mm. (1.8511 - 1.8529")
— flywheel side	32.025 - 32.064 mm. (1.2607 - 1.2623")
Diameter of camshaft journals	
— timing side	46.975 - 47.000 mm. (1.8494 - 1.8504")
— flywheel side	31.975 - 32.000 mm. (1.2588 - 1.2598")
Diameter of tappet guides	22.021 - 22.000 mm. (.8669 - .8661")
O/D of original tappet	22.000 - 21.979 mm. (.8661 - .9046")
Tappet oversize range (see chart on page 33)	0.05 - 0.10 mm. (.0019 - .0039")
I/D of rocker arms	15.032 - 15.059 mm. (.5918 - .5929")
Diameter of rocker arms spindles	14.983 - 14.994 mm. (.5899 - .5903")
I/D of inlet and exhaust valve guide housings	14.000 - 14.018 mm. (.5512 - .5519")
O/D of inlet and exhaust valve guides (original)	14.064 - 14.075 mm. (.5537 - .5541")
(spares)	14.107 - 14.118 mm. (.55541 - .55545")
I/D of inlet and exhaust valve guides (after pressing-in)	8.000 - 8.022 mm. (.3149 - .3158")
Dia. of inlet valve stem	7.972 - 7.987 mm. (.3138 - .3144")
Dia. of exhaust valve stem	7.965 - 7.980 mm. (.3136 - .3142")
Dia. of inlet valve head	38.4 - 38.6 mm. (1.5118 - 1.5197")
Dia. of exhaust valve head	34.4 - 34.6 mm. (1.3543 - 1.3622")

ENGINE LUBRICATION

DESCRIPTION

Oil sump also acts as oil tank and contains 3 liters (3-1/4 quarts) of Shell Multigrade 20/40 motor oil. Pressure type lubrication, suction and delivery by gear pump and recovery by gravity. Pump is gear driven by crankshaft (see Fig. 59). Oil is pumped directly from sump, cleaned by a wire gauze and delivered through suitable ducts in crankcase.

Oil pressure gauge, to indicate insufficient pressure, and oil relief valve, both on delivery circuit.

Oil is sent through main bearings to camshaft housings, crankshaft, and from here, through suitable ducts, lubricates con-rod big end bearings.

Oil then comes out from sides of big end bearings and owing to centrifugal force is spread all over engine parts. Cylinder heads lubrication is obtained through suitable piping. Engine lubrication system consists of the following parts: Oil pump - oil cleaner - oil piping with relief valve - piping to breather - recovery pipe from breather - oil breather - oil pressure gauge.

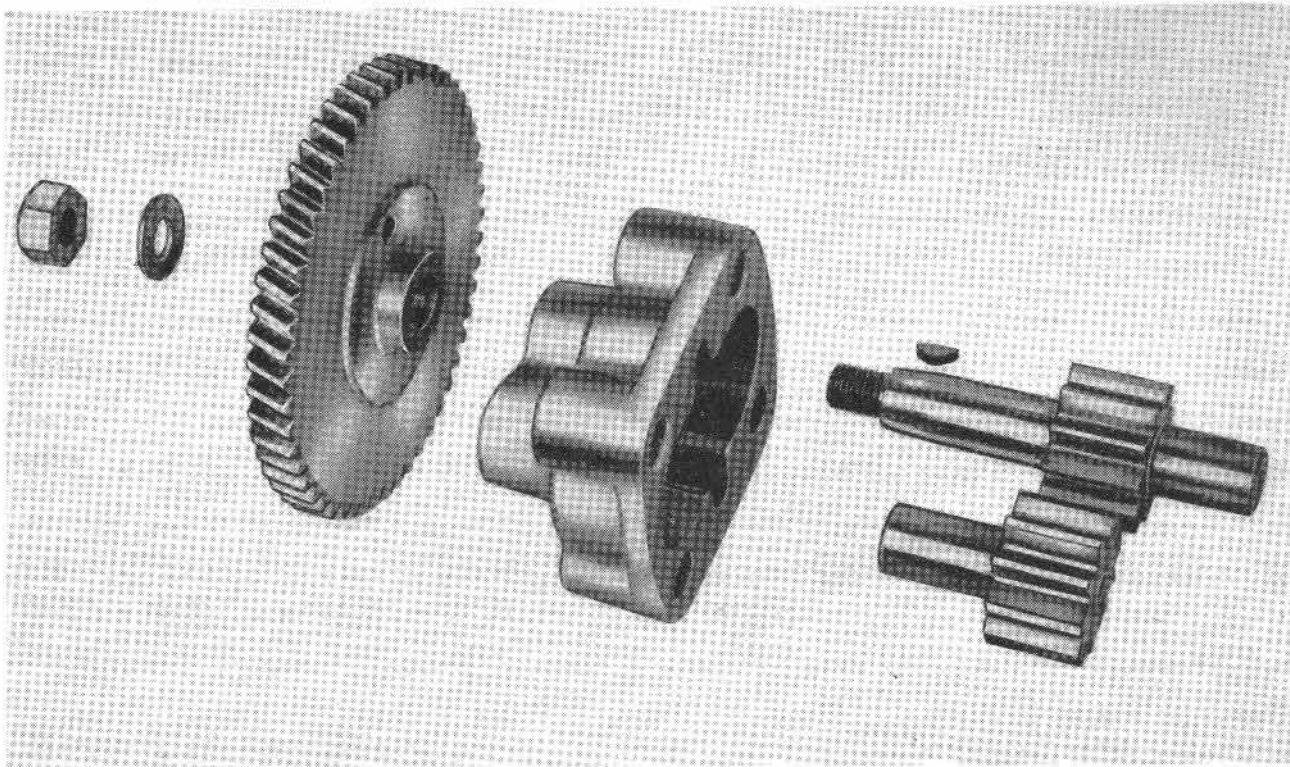

Fig. 59

OIL PUMP

Parallel gear type, located at left bottom of crankcase (see D on Fig. 15) and including driving gear directly coupled to gear on crankshaft.

INSPECTION AND CHECKS

If irregularities imputable to oil pump arise, check the following:

- gear width, to be 15.983 - 15.994 mm. (.6293 - .6297").

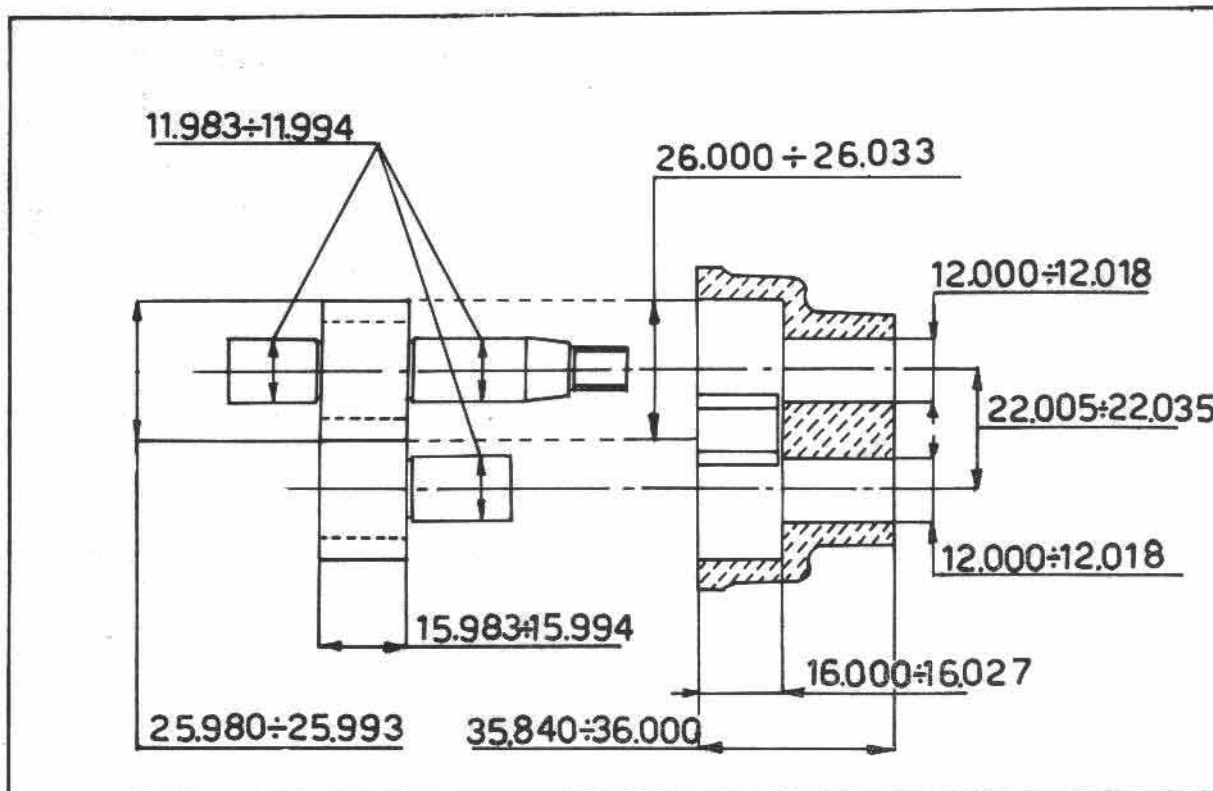

Fig. 60

— housing depth in pump body, to be 16.000 - 16.027 mm. (.6299 - .6309"). See Fig. 60.

Should actual measures be different from above, parts must then be positively replaced.

Another important check is about the O/D of gears, which must be 25.993 - 25.980 mm. (1.0233 - 1.0227"), while I/D of housings in pump body must be 26.000 - 26.033 mm. (1.0236 - 1.0249"). See Fig. 60.

Clearance between pump gear shafts 11.994 - 11.983 mm. (.4722 - .4717") and supports in pump body 12.000 - 12.018 mm. (.4724 - .4731") must be 0.006 - 0.035 mm. (.00023 - .00137") (see Fig. 61).

OIL CLEANER

Wire gauze type, located at center bottom of crankcase (see B on Fig. 15), and directly connected to oil pump.

When overhauling, cleaner must be entirely stripped down, washed with pure gasoline and

blown with compressed air. Make sure gauze is not damaged and, if necessary, replace it. Oil cleaner (see Fig. 62) consists of:

- wire gauze
- cleaner body

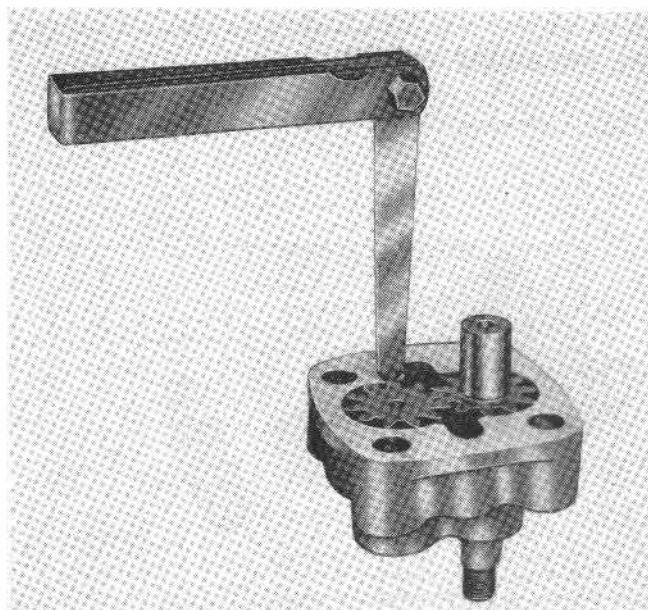

Fig. 61

- securing screws and washers
- bottom plate.

OIL PIPING

Clean thoroughly with pure gasoline and blow with compressed air.

OIL PRESSURE RELIEF VALVE

Located on oil pipe (see C on Fig. 15) it is rated to allow in circuit a delivery pressure of 2.5 - 3.0 kgs/sq.cm. (35.6 - 42.7 lbs/sq.in.). If pressure exceeds prescribed rating, valve opens thus restoring required pressure. It is strongly recommended not to tamper with this device, which has been set at Factory.

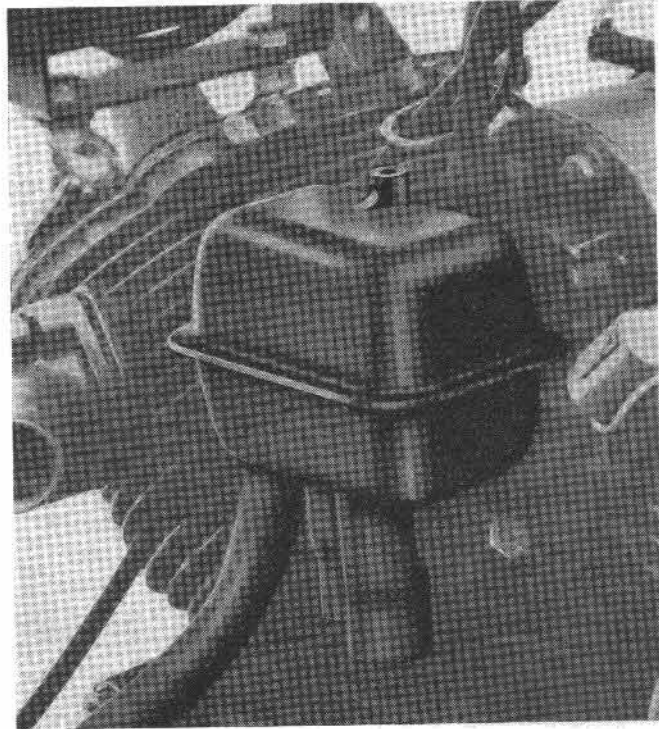

Fig. 63

OIL BREATHER (see Fig. 63)

Consisting of a box with a diaphragm retained against breather pipe from a previously rated spring. Breather tube, oil return tube and vent tube are connected to breather box by means of rubber sleeves and bands. Purpose of oil breather is to discharge excess pressure and it comes into action whenever relief valve opens to restore required oil pressure.

panel, indicates insufficient oil pressure in lubrication system.

When red warning light is shown (while running), it means that oil pressure is below required rating.

OIL PRESSURE GAUGE

Electrically connected to warning light on control

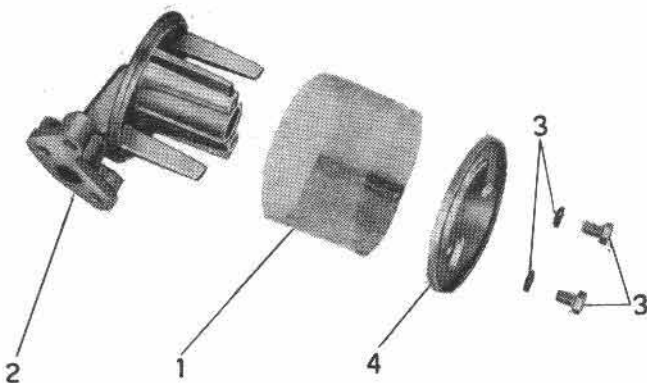

Fig. 62

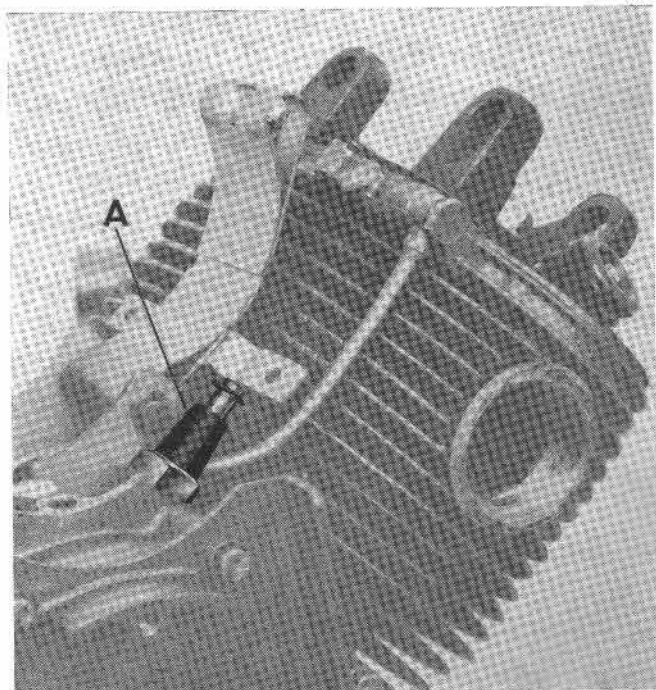

Fig. 64

ENGINE ASSEMBLING

After inspections, checks and replacements, clean all parts with pure gasoline and assemble engine as follows:

- secure timing side flange c/w main bearing by means of bolts and lock plates. After tightening bolts, bend lock plates ends against bolt panes.
- insert crankshaft in timing side flange c/w main bearing and fit over crankshaft the flywheel side flange c/w main bearing, securing the same to crankcase by means of bolts and lock plates. After tightening bolts, bend lock plates against bolt panes.
- insert camshaft in its housing in crankcase and then bolt down the camshaft support flange to crankcase.
- fit over crankshaft the con-rods c/w big end bearings, con-rods caps, and secure them to crankshaft by means of bolts, lock plates and nuts. Remember to bend lock plates against nut panes. Refer to chapter « CON-RODS » on page 23, paragraph « Fitting up con-rods on crankshaft ».
- secure oil pump to crankcase, by means of screws.
- connect oil cleaner (with gasket) to oil pump by means of the two screws.
- connect oil pipe (see A on Fig. 15) complete with relief valve and gaskets to crankcase, by means of bolts and lock plates. After tightening bolts, bend lock plates against bolt panes.
- secure oil sump to crankcase, after positioning new gasket and fitting oil drain plug. Tighten bolts in crossed sequence.
- fit pistons, c/w rings, on con-rods. To insert piston pin in piston and in con-rod small end bushing, use Tool No. 26907800 (see 17 on Fig. 14). Bear in mind that piston must be previously heated. Fit piston pin circlips.
- insert tappets in their housings in crankcase.
- position new gaskets between crankcase and cylinder.
- fit cylinders over long bolts. When fitting cylinders over pistons remember to lubricate piston crown and cylinder lining in order to obtain an easier fitment.
- insert new gaskets between cylinders and cylinder heads.
- fit cylinder heads c/w valves.
- secure rocker arm supports to cylinder heads by means of nuts and bolts. See paragraph « Assembling of cylinder heads on cylinders » on page 19. Make sure that sealing rings on bolts are in perfect condition.
- insert push rods in tappets.
- fit rocker arms, springs and washers on supports, inserting then spindles. Secure spindles to supports by means of bolts and washers.
- fit cylinder head oil pipe and gaskets, by means of bolts.
- fit flywheel over crankshaft and, after having positioned tool No. 12911801 (see 16 on Fig. 9) on gear box fixing bolts, secure same by bolts and lock plates. Use torque wrench and refer to paragraph « Crankshaft » on page 27. Remember to bend lock plates against bolt panes.
- fit woodruff key and distribution gear on crankshaft, timing side.
- fit key on oil pump gear driving shaft and then position driving gear, securing same with washer and nut.
- fit cam wheel, making sure that marked slot matches with dowel on camshaft and that the two marked teeth on cam wheel engage the marked tooth on distribution gear. To check this, use special tool No. 12912900 (see 20 on Fig. 57). To tighten nut securing cam wheel to camshaft use ring wrench and tool No. 12911801 (see 16 on Fig. 9).
- secure timing cover to crankcase, inserting new gasket, and using tool No. 12908300 (see 22 on Fig. 49) for an easy fitting of seal ring on crankshaft. Tighten the screws in crossed sequence, securing timing cover to crankcase.

- fit generator pulley, after positioning key on crankshaft, and tighten nut with ring wrench and special flywheel holding tool No. 12911801 (see 16 on Fig. 9).
- adjust tappet clearance (see paragraph «Tappet clearance adjustment» on page 37).
- fit new gaskets between cylinder heads and rocker box covers.
- secure rocker box covers to cylinder heads by means of socket head screws, to be tightened in crossed sequence.
- fit spark plugs.
- connect oil pressure gauge electric cable.
- secure generator support bracket to crankcase.
- fit generator securing bands, pins and cotter pins.
- position the generator, without tightening completely band screw.
- fit generator belt over crankshaft pulley and generator pulley. Adjust belt tension (see paragraph «Adjustment of generator belt tension») and tighten completely the generator band securing screw.
- secure distributor support to crankcase (insert new gasket) by means of screws and washers.
- insert distributor, mating its driving pinion with gear on camshaft.
- adjust contact breaker gap, check ignition timing (see paragraph «Ignition timing» on page 106) and then screw down bolt securing distributor to support.
- pour 3 liters (3-1/4 quarts) of Shell Multigrade 20/40 motor oil into oil filler in crankcase and fit filler cap c/w dipstick.

For assembling of clutch unit and starter ring gear to flywheel, see paragraph «Clutch assembling operation» on page 50.

ENGINE FEEDING

Engine is gravity fed by gasoline (98/100 NO Research Method). Gasoline coming from tank, through feed cocks (A) enters fuel lines (C) con-

veying same to four-way adapter and from here to carburetor filters (B). See Fig. 65.

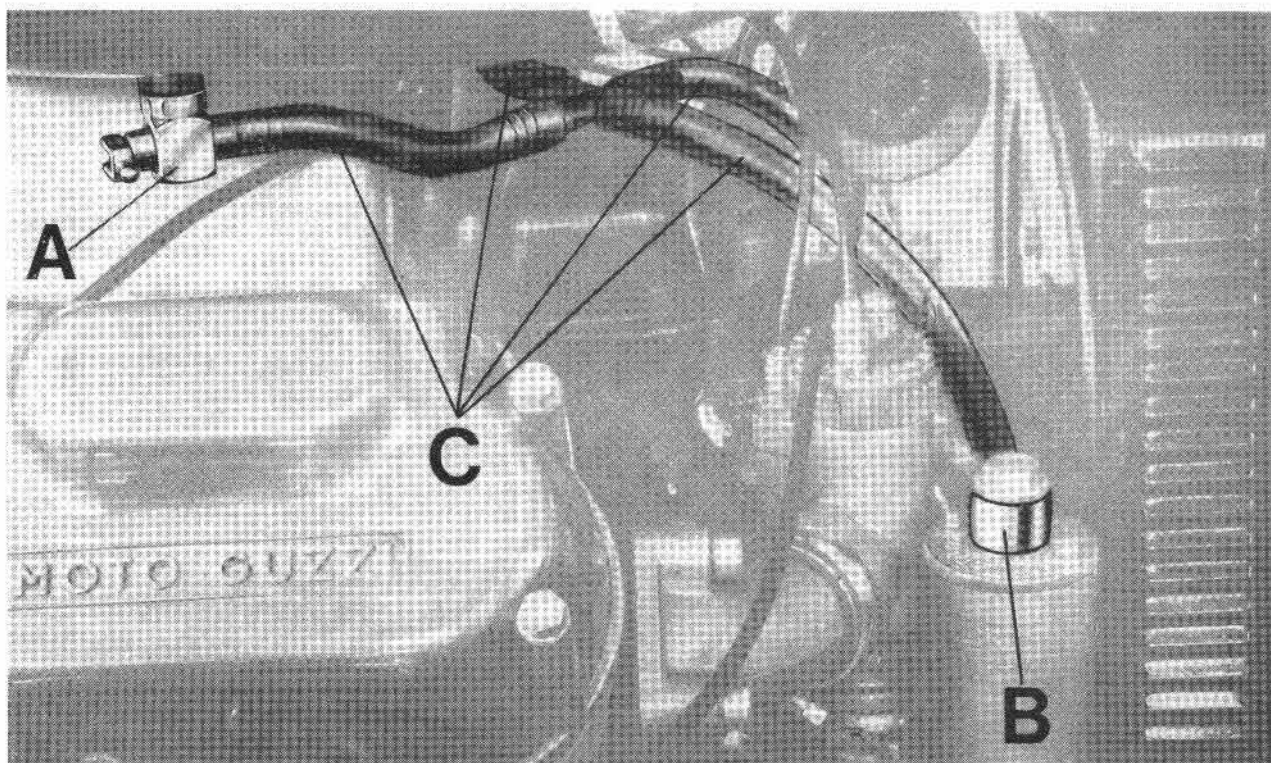

Fig. 65

FUEL TANK

Capacity 20 liters (5.28 US gls.) of which about 4 liters (1 US gl.) in reserve compartment. Fuel tank is cradle mounted on frame, over engine group, secured to frame by bolts and rubber buffers. Fuel filler cap on top of tank. Cap is pierced and periodical checks should be made that orifice is not clogged, because this could seriously upset carburation. Two fuel cocks with filters are located below tank. One of the two cocks is for reserve gasoline only and will only be opened when the other cock will not supply any more gasoline. Remember to operate once in a while reserve cock to be sure of its efficiency. Fuel cocks are open when levers are turned to R/H

side (A). They are closed when levers are turned to L/H side (B). See Fig. 66.

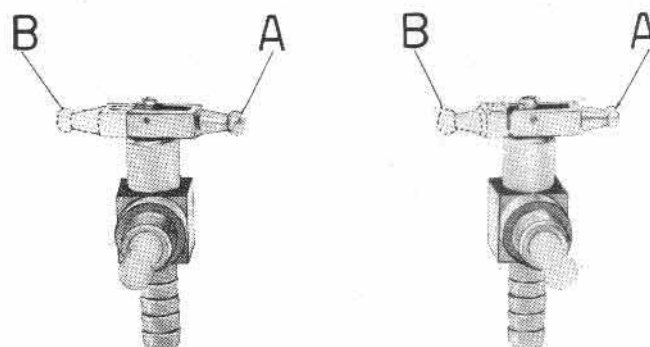

Fig. 66

AIR CLEANERS ON CARBURETORS

Paper cleaner element in perforated steel casing and plastic rims. Cleaner provides an efficient cleaning of air fed to carburetors. Cleaner element is situated in steel plate box secured to frame. Box is connected to carburetors through rubber sleeve (see Fig. 67). Air cleaner assembly consists of the following parts (see fig. 68):

1. Air cleaner box.
2. Air cleaner element.
3. Box cover.
4. Washers and screws securing cover to box.
5. Rubber connecting sleeve.

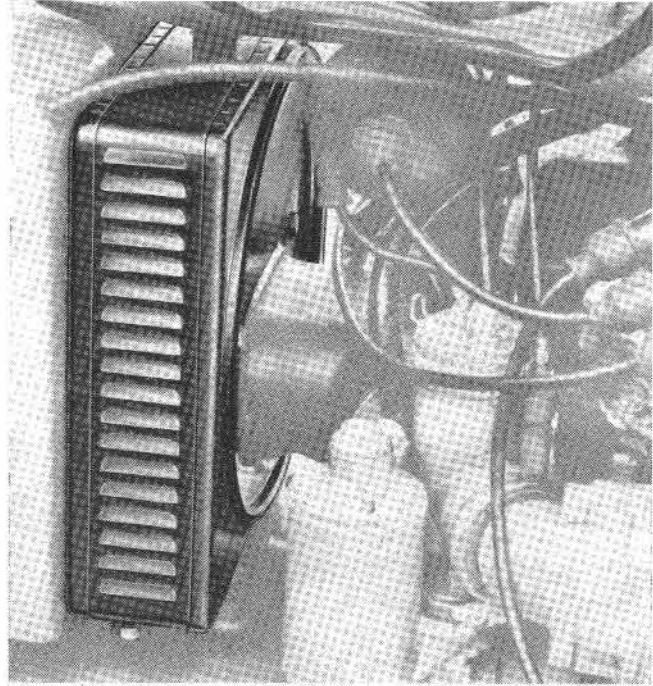

Fig. 67

EVERY 15.000 Kms. (9.000 miles)

It is best to change air cleaner element since paper filtering capacity could be greatly reduced. If using the machine in particularly dusty environments, this replacement must be carried out more often.

CARBURETORS

Two DELL'ORTO carburetors. SSI 29 DS type (R/H viewing engine from clutch) and SSI 29 D

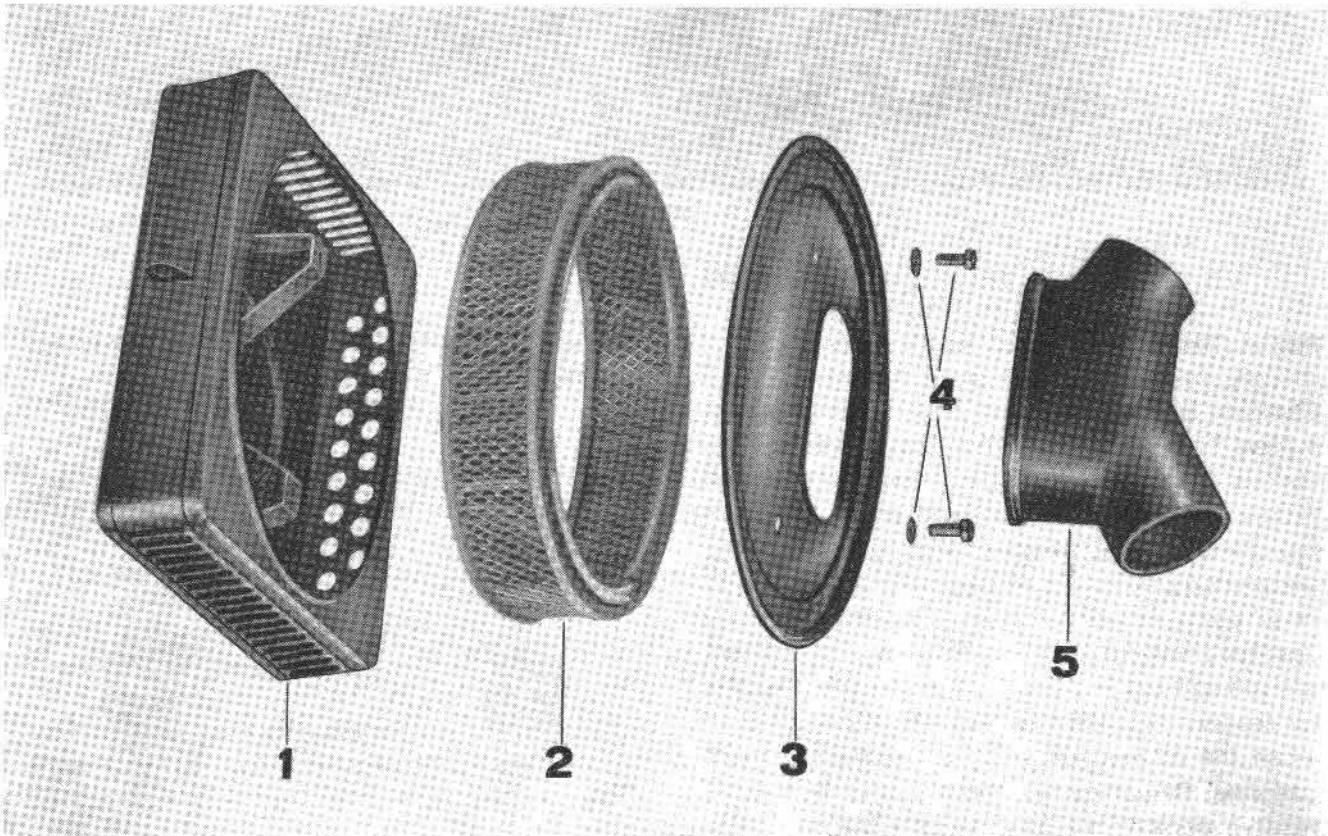

Fig. 68

type (L/H). Throttle is controlled by twist grip and air choke by hand lever. Both controls are located on R/H side of handlebar.

STANDARD CARBURETOR SETTINGS

Choke tube dia.	29 mm. (1.14")
Throttle slide	80
Atomizer	265
Main jet	120
Pilot jet	55
Needle	M14, third notch from top.
Floater	14 gr.
Idling screw	open 1 - 1-1/2 turns (see A on Fig. 69).

IDLING SPEED ADJUSTMENT

This adjustment must always be made on a hot engine.

Proceed as follows:

1. Ensure both adjusting screws are open about 1 - 1-1/2 turns.
2. Open twist grip throttle to about 1/4 and start engine.
3. Adjust throttle cables (by means of adjuster and nut on mixing chamber cap) to a position that both cylinders are firing even and with the same exhaust pressure.
4. Release twist grip and adjust throttle valves using adjusters (B) on top of carburetors to desired idling speed, at a position where both cylinders are firing evenly.
5. Adjust the idle screw (A) to obtain the best mixture. After this adjustment, if necessary, readjust throttle valves using adjusters (B) to obtain desired engine speed. If it is necessary to close the idle screws (A) completely, this means that pilot jets are too small and others having a larger orifice should be fitted. If it is necessary to open the idle screws more than 1 - 1-1/2 turns, this means that pilot jets are too large and others with a smaller orifice should be fitted.

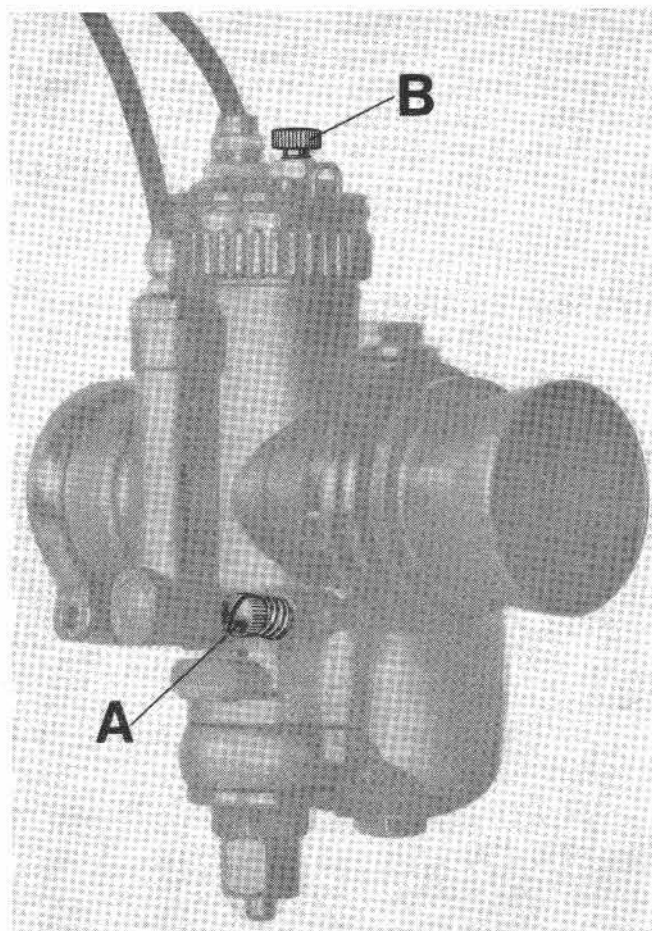

Fig. 69

6. At the end of above operation recheck to ensure that both throttle valves are synchronized and open at the same time. Remember to lock in position cable adjusters and throttle valve stop bolts.

TOP SPEED ADJUSTMENT AND MAIN JET SELECTION

Adjustment is made changing to a larger size main jet if mixture is too weak and to a smaller size jet if mixture is too rich. To determine the correct size of main jet proceed as follows:

1. If on opening the throttle the engine is slow in picking up speed and the machine does not go faster or decelerates and shows a tendency to backfire, and on opening the air lever there is some improvement, then the mixture is too poor due to a too small main jet. In such case increase the jet size which will give the best performance.

2. If on opening the throttle a duller exhaust tone is noticed and the engine ejects black smoke, also if on slightly opening the air lever this condition accentuates, then the mixture is too rich and a smaller jet should be fitted.

STRIPPING OF CARBURETOR

Remove the following:

- mixing chamber cap (1) after removal of clip (2).
- mixing chamber cover (3), throttle slide spring (4), throttle slide (5) c/w taper needle (6), and choke (6/1).
- air adjusting screw and spring (7), pilot jet (8).
- bowl plug (9), float chamber securing bolt (10), washers (11), float chamber (12), main jet (13), jet holder (14) c/w atomizer and atomizer nozzle.
- carburetor body (15) and cable tensioning assembly (16).
- float chamber cover c/w tickler (17), adapter plug (18), adapter (19), filter (20) and plug washers (21).
- float chamber bottom plug (22), floater (23) c/w needle (24).

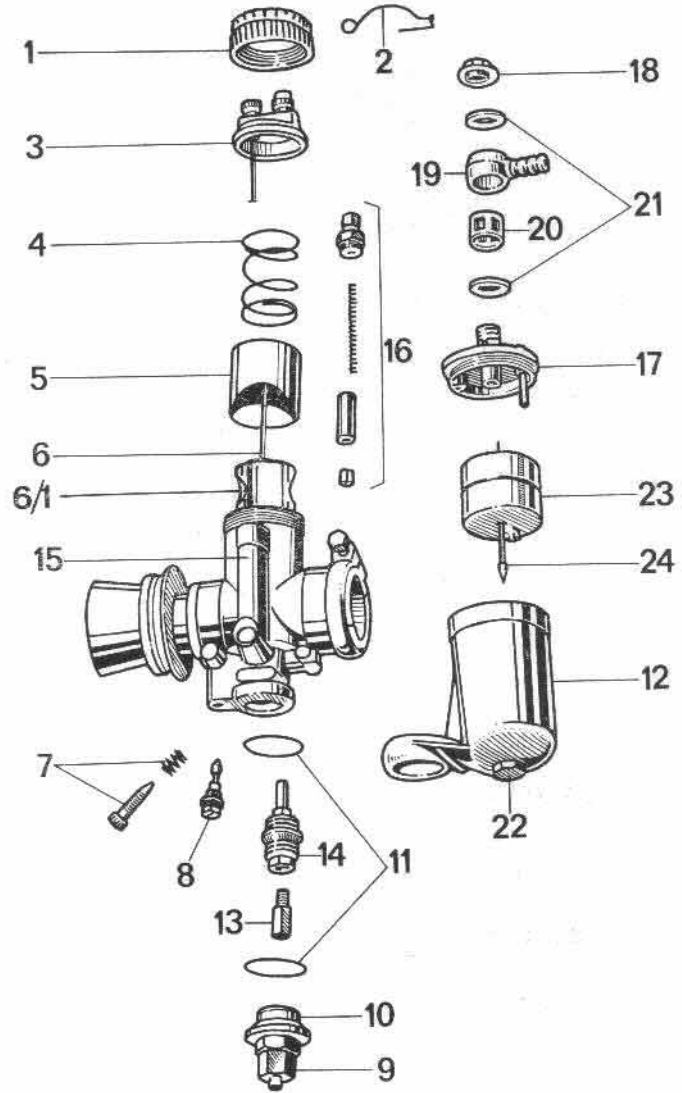

Fig. 70

After the carburetor has been stripped down clean all parts with pure gasoline and dry off with compressed air jets and clean carburetor ducts. It is also advisable, when overhauling, to inspect and clean all fuel filters and lines from tank to carburetor.

SERVICING OF CARBURETOR

Keep carburetor in perfect condition in order to obtain best working efficiency.

Thorough cleaning

Periodically strip down carburetor and carefully clean all parts with pure gasoline. Dry off with compressed air and blow through all ducts and holes. Assemble carburetor ensuring perfect fitting of every part.

Good upkeep

After stripping down, check very carefully the condition of all parts and particularly the following:

Throttle slide: check perfect sliding in mixing chamber and in case of excessive wear replace it.

Taper needle

Check if wear marks appear on tapered surface or in notches and if necessary replace it.

Atomizer

Check periodically the condition of gauged part entered by taper needle. It is best to have this check made at a DELL'ORTO service station. In case of wear replace part with ORIGINAL of same size.

N.B.: Bear in mind that correct fuel consumption is directly related to good condition of taper needle and atomizer.

Main jet

Ensure that jet orifice is never tampered with in order to alter setting and not cleaned with a wire either, unless of much smaller size and tender material. This for avoiding involuntary widening of orifice which would in turn increase consumption and upset carburation. In case of wear replace main jet with ORIGINAL part of same size.

Pilot jet

The same rules as above are valid also for pilot jet.

Constant level float chamber

Good operation of this carburetor part is essential for a correct carburation. Check periodically the following parts:

A - Float needle

Ensure that tapered section of needle is in perfect condition. In case of seizing marks or wear replace it.

B - Float needle seat

Check that seat corner contacting needle is not deteriorated or damaged. If so, replace it.

C - Float

Ensure that float is not made heavier by possible gasoline seeping and that float needle is perfectly secured.

Fuel filter

Check this filter often, clean it with pure gasoline and dry it off by compressed air.

ENGINE BRAKE TEST

After overhauling, engine must be suitably run-in and bed tested for output.

POSITIONING OF ENGINE ON TEST BED

Position engine on test bed and connect exhaust pipes, fuel lines and electric cables. Couple fly-wheel to hydraulic brake shaft and proceed to test.

TESTING RULES AND METHODS

After starting engine, check carefully the following:

- if there is any oil leaking from gasket or gasoline from lines.

- if oil circulation takes place regularly and if pressure is 2.5-3 Kg/sq.cm. (35-42 lbs/sq.ins.) as prescribed.

- Should any irregularity appear, stop engine and eliminate the cause before proceeding any further. During initial period of test, engine lacks elasticity and shows a remarkable resistance to rotation, mainly due to the friction of parts which need a long run before settling. This is particularly experienced with engines which have had replaced pistons, main bearings and conrod bearings and have had main journals and crankpin reground. It will be necessary therefore, to give to the engine the following running-in cycle.

- total running-in period 4 hours, 5 minutes of which at top speed (6000 RPM).

After running-in, if no irregularity arises, engine is ready to record output and to be assembled to gearbox.

CLUTCH

Twin driven plates, dry type (see Fig. 71). Clutch unit consists of the following parts:

- No. 8 springs, peripherically located inside flywheel in suitable housings.
- externally toothed pressure plate with housing for pressure cap.

- driven plate, c/w facing.
- externally toothed intermediate plate.
- driven plate, c/w facing.

Clutch unit is located inside flywheel, retained by starter ring gear which is secured to the flywheel by means of 8 bolts and spring washers. Ring gear is driven by starter motor.

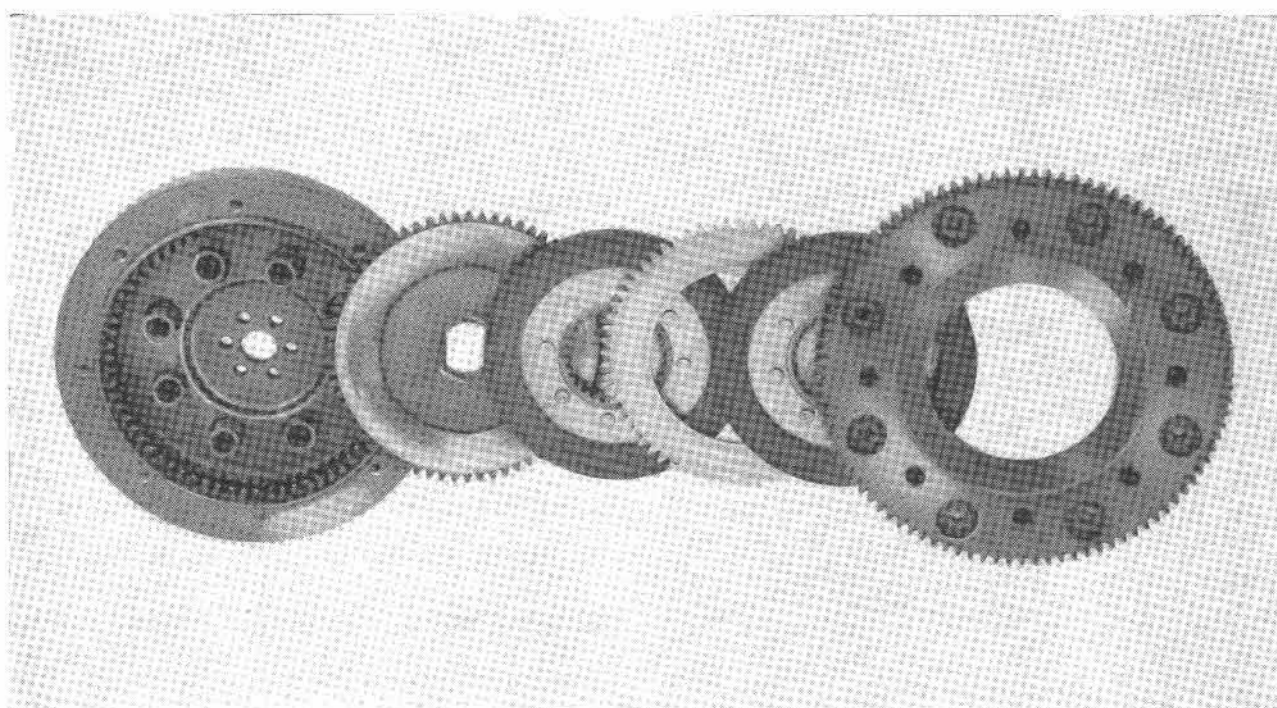

Fig. 71

REMOVAL OF CLUTCH ASSEMBLY

Remove gearbox group from engine, undo the 8 bolts securing starter ring gear to flywheel and extract driven plate, intermediate plate, driven plate, pressure cap, pressure plate and springs.

CHECKING CLUTCH SPRINGS (see Fig. 72)

Check perfect efficiency of springs. Spring, compressed at 20 mm. (.7874") must show a load of

Kg. 16 $\begin{matrix} +0 \\ -10\% \end{matrix}$ (35.27 lbs. $\begin{matrix} +0 \\ -10\% \end{matrix}$).

Spring, compressed at 17 mm. (.6692") must show

a load of Kg. 24 $\begin{matrix} +0 \\ -10\% \end{matrix}$ (52.9 lbs. $\begin{matrix} +0 \\ -10\% \end{matrix}$).

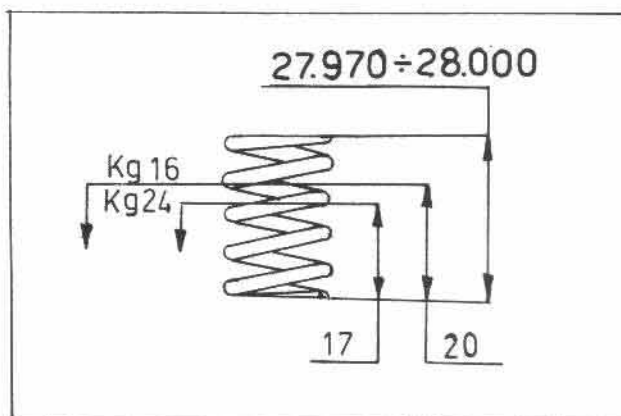

Fig. 72

CHECKING PRESSURE PLATE

Check that pressure plate does not show any cracking on the two sectors engaging pressure cap and that surface contacting driven plate is perfectly flat, otherwise noisy clutch operation will ensue. Also check condition of teeth engaging inside of flywheel.

CHECKING DRIVEN PLATES

Total thickness of each new plate, including facing, is 8 mm. (.3149"). Replace plate when such thickness reaches 7.5 mm. (.2953").

CHECKING INTERMEDIATE PLATE

Check that surfaces contacting driven plates are perfectly flat, otherwise noisy clutch operation will ensue. Also check condition of engaging teeth inside of flywheel.

CHECKING STARTING RING GEAR

Check that surface contacting driven plate is perfectly flat otherwise noisy clutch operation will ensue. Also check that teeth engaged by starter motor pinion is not deteriorated or cracked. If necessary replace ring gear.

CLUTCH ASSEMBLY OPERATIONS

Flywheel is secured to crankshaft by means of bolts and lock plates (3.5 Kg/m. torque-25 ft/lbs. see Fig. 9) outside flywheel there is an arrow which, besides indicating T.D.C. is also a reference mark for fitting clutch pressure plate. Correct assembling of clutch unit is made as follows:

- insert the 8 springs in their housings in flywheel and locate pressure plate in flywheel ensuring that punched tooth of pressure plate fits flywheel in correspondence with arrow marked on same.
- fit tool No. 12906500 (see 21 on Fig. 8) on crankshaft, screwing it down enough to allow the correct positioning of far side driven plate, intermediate plate, near side driven plate and starter ring gear and then tightening down bolts securing ring gear to flywheel. To

prevent rotation of flywheel while tightening above bolts, fit special tool No. 12911801 (see 16 on Fig. 8) to gearbox fixing bolts.

CLUTCH CONTROL

Clutch control consists of:

- clutch control lever on L/H side of handlebar
- clutch cable (from control lever to lever on gearbox)
- clutch operating lever on gearbox
- clutch outer body and circlip
- cage complete with balls in gearbox
- clutch inner body in gearbox
- clutch pressure rod and pressure cap

CHECKING CLUTCH CONTROL

Check that clutch cable is unimpaired, without broken wires. If necessary replace it.

CHECKING CLUTCH OPERATING LEVER ON GEARBOX

Check that lever dowel is in perfect condition.

OUTER BODY

Check surface contacted by lever dowel. If impression is very deep, replace body.

CAGE C/W BALLS

Check that balls are in perfect condition, otherwise replace them.

INNER BODY

Check surface engaged by cage balls. If damaged, replace part.

PRESSURE ROD

Check that rod is not damaged or deformed, otherwise replace it.

PRESSURE ROD CAP

Check that it is not very damaged or worn out, otherwise replace it.

OUTER BODY SEAL RING

Check that seal ring has not lost elasticity and that is not crumbled, otherwise replace it.

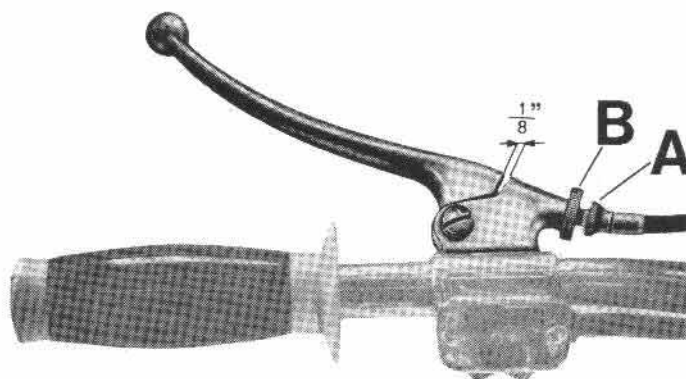

CLUTCH ADJUSTMENT

Check that clutch lever on L/H side of handlebar has the correct free movement of about 4 mm. (1/8") between lever and static body of same. If play is more or less than that, adjustment is needed. Slacken thumb screw (B) and obtain correct distance screwing in or out adjuster (A). Adjustment can also be made slackening nut (D) and acting on adjuster (C) bolted on the battery support plate (see Fig. 73).

After adjusting, remember to lubricate cable terminals, operating lever a few times in order to allow lubricant to get inside cable sheathing.

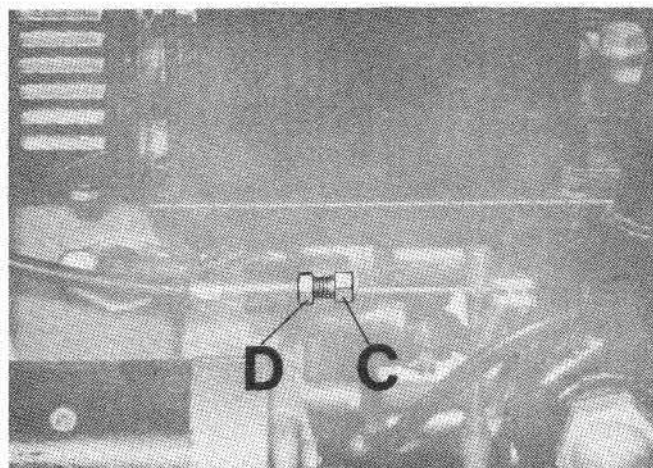

Fig. 73

GEAR BOX (see Fig. 74)

Separate case bolted on crankcase, constant mesh gear, frontal engagement.

Engine - gearbox ratio 1:1.373 (16-22)

Internal gear ratios:

— Low gear 1:1.933 (15-29)

— Second gear 1:1.263 (19-24)

— Third gear 1:0.954 (22-21)

— Top gear 1:0.754 (24-18)

GEAR BOX DESCRIPTION

Mainshaft, driven by driving gear on clutch shaft, drives layshaft. Mainshaft is provided with four fixed gears. Layshaft is provided with four frontal engagement gears, two sliding sleeves and speedometer drive gear, and it is secured outside gear box cover by lock ring and tab washer. Gearshift is directly operated by rocker pedal on the R/H side of machine.

Operating the rocker pedal, this will control the selector shaft whose toothed sector will engage gear on inner selector body. The latter, complete with springs, pawls and plungers, operates in selector drum cavities and on camplate, thus controlling selector drum. On selector drum there are five holes (Low gear - Idle - 2nd gear - 3rd gear - Top gear). Depending on the gear engaged at the moment, a pawl, pressed by a spring, will be positioned in one of the five holes. This pawl is drilled through and it is incorporated in gearbox drain plug, also working as a gearbox breather.

Selector drum, by means of slots in same, controls gear selector forks which in turn operate sliding sleeves frontally engaging the selected gear. Gearbox is also provided with a neutral indicator unit electrically connected to control panel. When inserting ignition key (pos. 2),

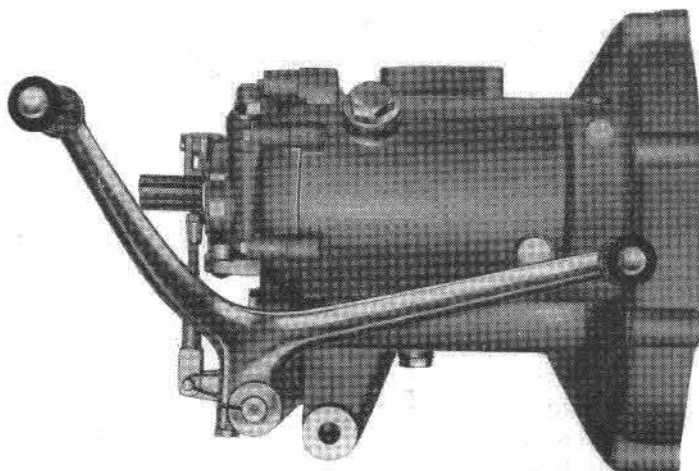

Fig. 73/1

should any gear be engaged, orange warning light will **not** show. Remember not to start engine if warning light is not on.

GEAR BOX CONTROL (see Fig. 75)

Gearshift is controlled by rocker pedal located on R/H side of machine. Pushing front bar of

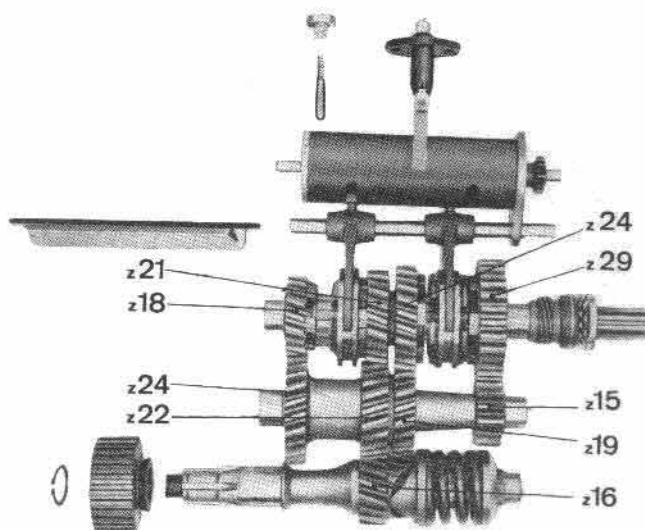

Fig. 74

pedal will shift to a higher gear, while pushing back bar will shift to a lower one. Idle running is between low gear and 2nd gear. To select idle gear shift back to low gear and then push front bar half way down.

GEAR BOX STRIPPING

Before beginning to strip down the gearbox drain oil contained therein by unscrewing drain plug (see Fig. 75).

Remove the following:

- clutch operating lever
- rocker pedal
- speedometer cable
- layshaft lock ring by means of special wrench No. 12905400 (see 5 on Fig. 76), after having disengaged tab washer by means of tool No. 12907100 (see 18 on Fig. 76).
- layshaft spacer
- speedo drive gear
- selector cover, c/w shaft and sector, spring and offset adjusting screw, by unscrewing cover screws.
- gear box cover, after removal of the 10 screws securing same to gear box.
- clutch outer body, clutch cage and pressure rod.

From inside gearbox remove now the following:

- clutch inner body circlip and inner body
- oil pick-up plate.
- breather plug, spring and pawl acting on selector drum.

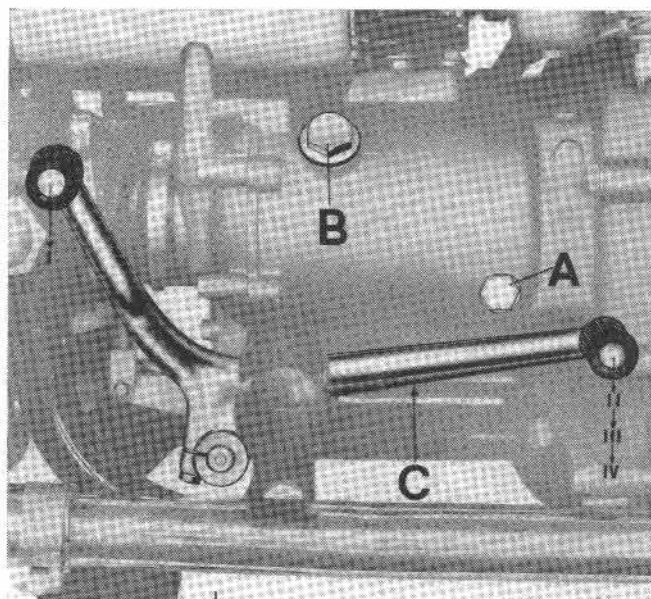

Fig. 75

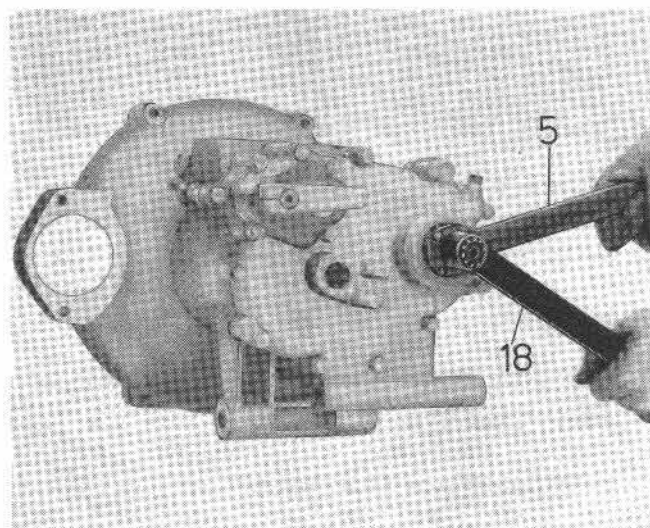

Fig. 76

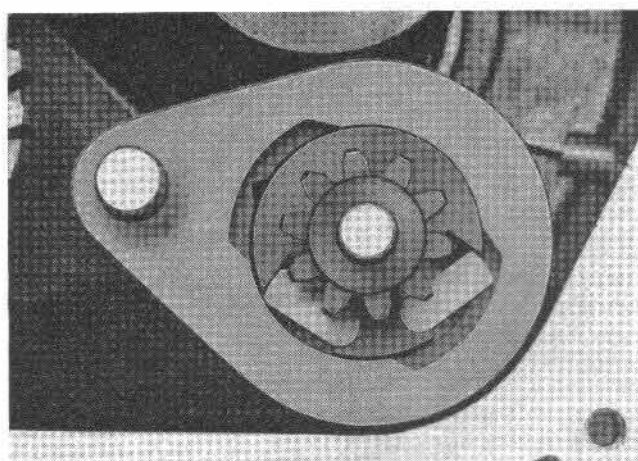

Fig. 76/1

- gear control cam plate.
- selector inner body, c/w plungers, pawls and springs (see Fig. 76/1).
- selector drum rod, extracting then selector drum after disengaging fork ends.
- fork shaft, removing then forks from layshaft.
- layshaft c/w gears and sliding sleeves.

Remove now the following parts from layshaft:

- adjusting washer
- low gear
- circlip
- 2nd speed gear.
- 4th speed gear floating bush.
- 4th speed gear
- thrust washer
- 3rd speed gear
- mainshaft, thrust washers and intermediate washer, top gear side.
- clutch shaft c/w cush drive.

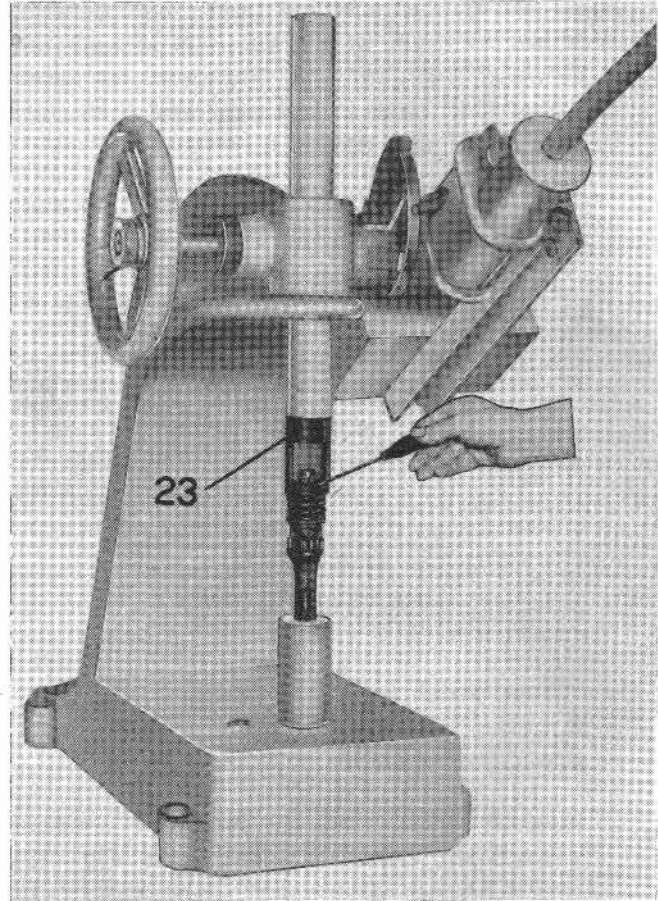

Fig. 78

Remove from clutch shaft (see note below) the following parts:

- the two cush drive plate semicollars.
- cush drive plate.

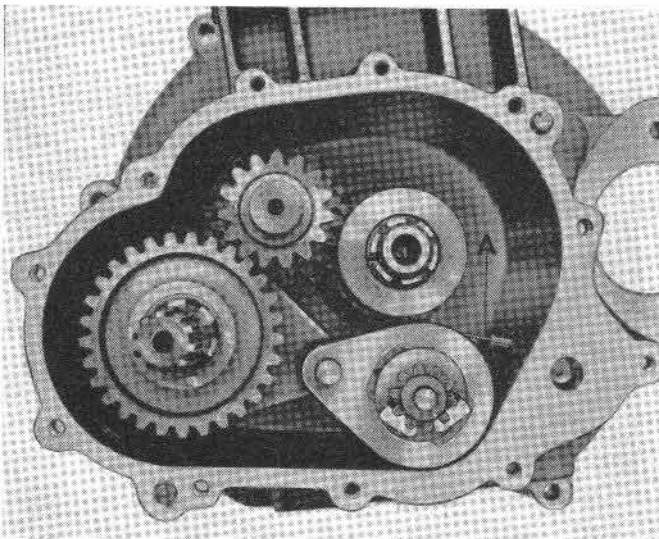

Fig. 77

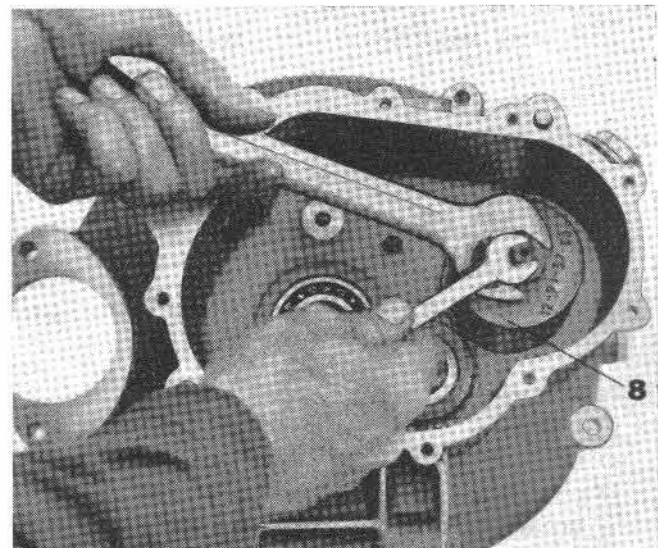

Fig. 79

- cush drive spring.
- sliding muff.
- clutch shaft to mainshaft driving gear.

Note: To remove the above parts from clutch shaft it is necessary to position the shaft on a pressing machine and after having fitted tool No. 12905900 (see 23 on Fig. 78), press down enough to remove the two semicollars from shaft groove.

Further parts to be removed are:

- neutral indicator unit (see A on Fig. 77).
- Filler plug and drain plug (B and A on Fig. 75).
- Seal in gear box, for clutch shaft.
- Seal, in box cover, for layshaft.

GEAR BOX

Remove from gearbox the following parts:

- Ball bearing for layshaft, using puller No. 12913700 (see 8 on Fig. 79).
- Roller bearing for mainshaft, using puller No. 12913100 (see 9 on Fig. 80).
- Ball bearing for clutch shaft, by means of round punch.

GEAR BOX COVER

Remove:

- Ball bearings for mainshaft and clutch shaft, using puller No. 12907000 (see 10 on Fig. 81 - 82).
- Ball bearing for layshaft, by means of round punch.

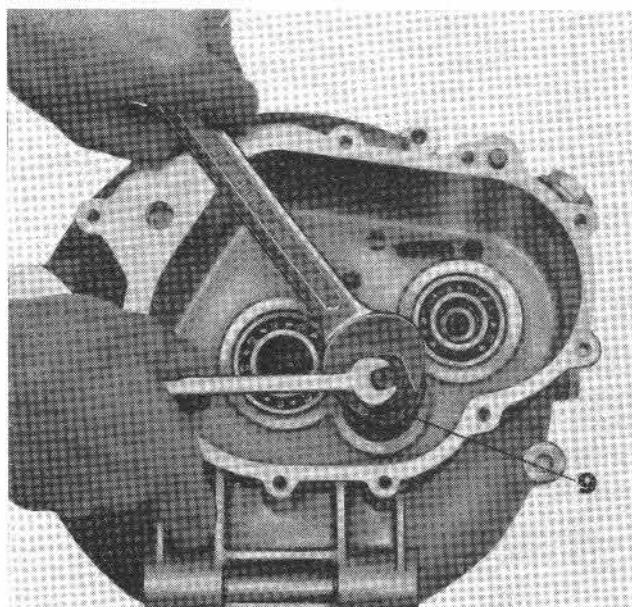

Fig. 80

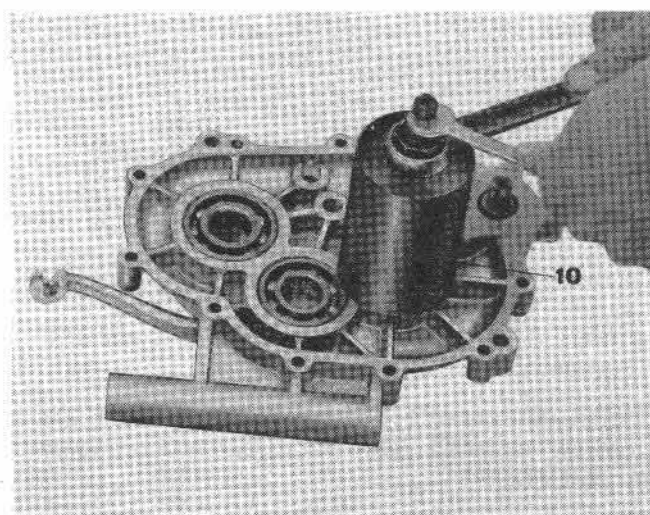

Fig. 81

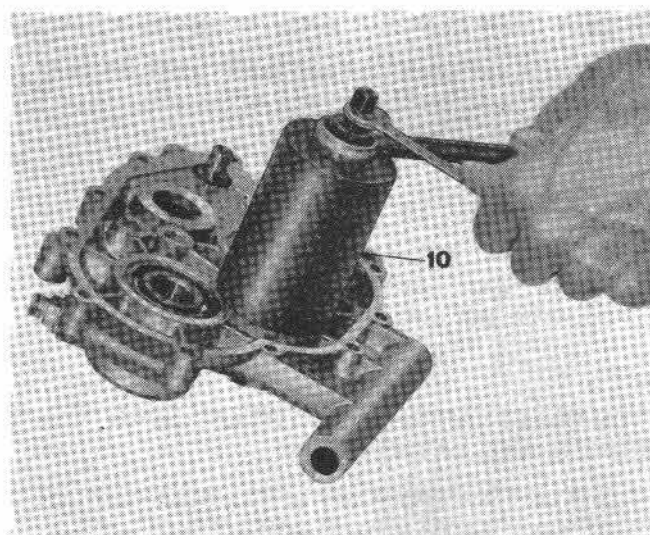

Fig. 82

Check and overhaul of the gearbox unit parts

GEARBOX AND COVER

- gear box must not show any cracks.
- surfaces coupled to crankcase and cover must not be scored or damaged.
- threads of bosses must not be stripped.

SEAL RINGS

Check that seal rings have not lost their flexibility and are not burred. If necessary replace them.

BALL BEARINGS AND ROLLER BEARINGS

- bearings must be in perfect condition and must not have an excessive slack.
- rolling surfaces must be even and smooth.
- balls and rollers must be unimpaired and smooth all over.

Should any imperfection be detected, bearings must be replaced (see paragraph «Bearings» on page 80).

MAINSHAFT

- gear teeth must not show excessive wear.
- contact surfaces of gear teeth must be very smooth, without chippings or cracks.

LAYSHAFT

Layshaft must not show any pit or chipping anywhere and surfaces contacting bushings must be perfectly smooth.

FITTING CLEARANCE BETWEEN GEAR BUSHINGS AND LAYSHAFT

- I/D of 1st - 2nd - 3rd speed gear bushing: 27.040 - 27.061 mm. (1.0646 - 1.0655")
O/D of layshaft bushing support for the 1st,

2nd, and 3rd speeds: 26.987 ÷ 27.000 mm. (1.0624 ÷ 1.0630")

- bushing - layshaft fitting clearance: 0.040 - 0.074 mm. (.0016 - .0029")
- I/D of top gear floating bushing: 20.007 - 20.028 mm. (.7877 - .7885")
O/D of layshaft floating bush support for the high speed gear: 19.987 ÷ 20.000 mm. (.7868 ÷ .7874")
- bushing - layshaft and fitting clearance: 0.007-0.041 mm. (.0003 - .0016")

LAYSHAFT GEARS

Gears must not show any imperfection or excessive wear on teeth or frontal engagement face teeth.

Contact surfaces of teeth must be perfectly smooth, without any imperfection. When bushings fitted in above gears are too worn out, they must be replaced.

After pressing in, the new bushings must be rebored to the sizes shown in following paragraph.

FITTING CLEARANCE BETWEEN BUSHINGS AND GEARS ON LAYSHAFT

- O/D of 1st - 2nd - 3rd speed gear bushings: 31.060 - 31.099 mm. (1.2228 - 1.2243")
- I/D of 1st - 2nd - 3rd speed gears: 31.000 - 31.025 mm. (1.2205 - 1.2214")
- gear bushings negative allowance: 0.035 - 0.099 mm. (.0014 - .0039")
- O/D of 4th gear floating bush: 22.960 - 22.939 mm. (.9039 - .9031")
- I/D of 4th speed gear: 23.021 - 23.000 m. (.9063 - .9055")
- 4th speed gear - floating bushing fitting clearance: 0.040 - 0.082 mm. (.0016 - .0032")

SLIDING MUFFS

Sliding surfaces must be positively smooth and frontal engagement teeth must not show any chipping or mark.

CLUTCH SHAFT

It must not show any imperfection or excessive wear, otherwise replace it.

CLUTCH SHAFT SEAL RING

Check it has not lost flexibility and it is not burred. If necessary replace it.

INNER BODY

Teeth must not show any deterioration or excessive wear, contact surfaces of teeth must be positively smooth, without chippings or marks. If necessary replace it.

CUSH DRIVE PLATE SEMICOLLAR

Check that they are not cracked, and if necessary replace them.

CUSH SPRING PLATE

It does not require any particular check, except for the internal grooves which must be very smooth.

CUSH DRIVE SPRING

Check that it is perfectly efficient. Spring compressed at 35 mm. (1.378") must show a load of Kg. 109 (240 lbs.). If any deformation or yielding is noticed, spring must be replaced.

SLIDING SLEEVES

Check that internal splines are perfectly smooth and that wear of engaging surface is not excessive.

IDLE GEAR

Idle gear must not show any imperfection or excessive wear. Contact surfaces of teeth and inner splines must be smooth, without chipping or marks.

GEAR SELECTOR DRUM

Check:

- drum grooves. Side faces of same must be perfectly smooth.
- camplate and cavities engaged by selector inner body. Wear must not be excessive.
- the drilled-through selector pawl and its spring. Check spring has not lost elasticity and it is not deformed. Pawl head must not be damaged and ensure that through-hole is not clogged up.
- teeth of selector inner body. Wear must not be excessive.
- elasticity of plunger springs. Wear of plungers and pawls must not be excessive.

PRESELECTOR SHAFT WITH SECTOR GEAR

Check that teeth of sector gear does not show excessive wear and that contact surface of teeth is very smooth, without chipping or marks. Also check that splines for fitting operating lever are very smooth.

PRESELECTOR SHAFT RETURN SPRING

Check that spring has not lost elasticity and it is not cracked. If necessary replace it.

GEARSHIFT OPERATING LEVER

Check that internal splines are perfectly smooth and that thread for securing screw is not stripped. If necessary replace part.

GEAR SELECTOR FORKS AND FORK SHAFTS

Check that forks controlling sliding sleeves have working surfaces positively smooth and not worn out to the extent of having lost their hardness.

ASSEMBLING OF GEARBOX

To assemble the gearbox unit, operate in reverse sequence than for stripping down, that is to say as follows:

- press in bearings. Pressing layshaft bearing in box remember to insert bottom plate to lubricate 4th speed floating bush.
- fit on box, clutch shaft seal ring.
- fit mainshaft, bearing in mind to insert thrust washer, intermediate washer and the other thrust washer between roller bearing and shaft at 4th speed gear side.
- lay on bearing the 4th speed gear c/w floating bush and the thrust washer and then insert layshaft c/w gears (except 1st speed gear) inside thrust washer, 4th speed gear and finally inside bearing box.
- fit clutch shaft c/w idle gear, sliding muff, cush drive spring cush spring plate and semicollars. When housing clutch shaft in gearbox, to avoid to damage seal ring use tool No. 12910700 (14 on Fig. 83).
- fit selector forks over the two sliding sleeves in layshaft.
- fit selector drum.
- locate fork ends in selector drum grooves.
- fit fork shaft into fork eyes and fit camplate on fork plate.
- rotate selector drum to allow selector pawl to enter 4th gear position hole and sliding sleeve to be engaged in 2nd speed gear.
- fit selector inner body c/w springs, plungers and pawls, as shown on Fig. 76/1.
- fit 1st speed gear on layshaft.
- fit adjusting washer.
- fit oil pick-up plate in its housing in gearbox.
- insert neutral indicator unit, ensuring positive contact between gear box and cover.
- fit gearbox cover, tightening screws in crossed sequence.
- fit speedo driving gear on layshaft.
- fit spacer on layshaft.
- fit tab washer.

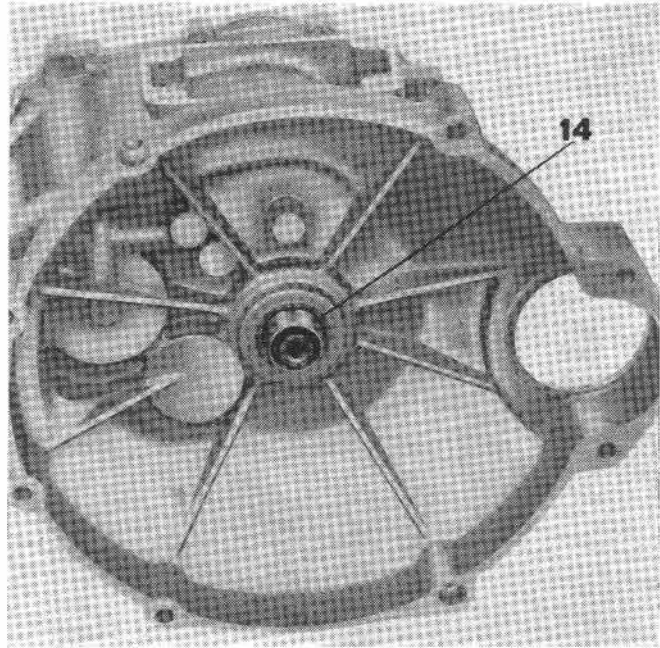

Fig. 83

- fit lock ring, using tool No. 12907100 (see 18 on Fig. 76) and special wrench No. 12905400 (see 5 on Fig. 76). Then bend down tab in lock ring slot.
 - fit in selector cover the following parts: pre-selector shaft with sector gear, return spring and offset adjusting screw c/w washer and nut.
 - fit selector cover assy, inserting new gasket and making sure that sector gear is engaged on selector inner body. Tighten short and long screws in crossed sequence.
 - fit gearshift operating lever, securing same to preselector shaft by means of two circlips to be positioned in grooves in clutch shaft.
 - fit clutch rubber tube, pressure rod, inner body, cage and outer body c/w seal ring.
 - fit clutch operating lever to gearbox, by means of pin and cotter pin.
 - fit oil drain plug.
 - pour into oil filler 0.750 liters (1-3/4 pts.) of SHELL Spirax 90 E.P. oil and check that oil starts to leak out from level hole. Both filler cap and level plug with their washers can now be replaced on crankcase.
 - adjust gear shifting release, acting on offset screw. Don't forget to re-lock the nut.
- The Gearbox Unit is now ready to be assembled to engine.

REAR WHEEL DRIVE

DESCRIPTION

Universal double joint and «GLEASON» type bevel gear. Double joint fitted on rear swinging fork bearing, coupled at one end to serrated gearbox layshaft and at opposite end to serrated drive shaft located inside R/H arm of rear fork. Drive shaft and serrated bevel gear pinion coupled by sleeve. Pinion teeth directly engage crown teeth of bevel gear set which, thru internally toothed sleeve, drives rear wheel.

Layshaft - bevel gear ratio:

1:4.625 (8.37)

Overall gear ratios:

Low gear : 1: 12.292

2nd gear : 1: 8.031

3rd gear : 1: 6.066

Top gear : 1: 4.794

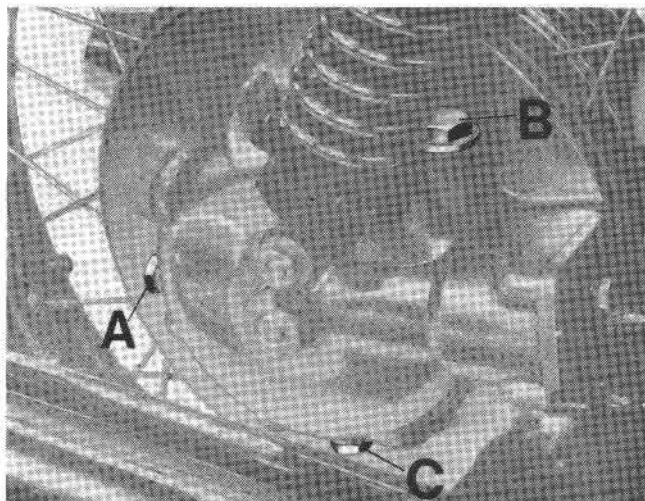

Fig. 84

STRIPPING OF REAR WHEEL DRIVE

First drain oil from drive box by removing drain plug and gasket (see C on Fig. 84) located at bottom of same and then proceed to strip as follows:

When engine-gearbox group is fitted over the machine:

- remove rear wheel (see paragraph «Rear wheel» on page 75).
- unscrew the four nuts (or bolts) with spring washers and remove drive box c/w sleeve and drive shaft.
- remove drive shaft from sleeve and remove the two circlips from shaft.
- remove sleeve from bevel pinion.
- remove gasket and oil seal from drive box.
- by means of tool No. 12907100 and special wrench (see 18 on Fig 85) remove locking securing bevel pinion, after having flattened safety washer.
- remove bearing housing, and from housing extract bevel pinion, the two bearings, shims and distance piece.
- remove housing - drive box gasket and seal ring.

- unscrew the 8 bolts securing flange to drive box, after flattening lock plates.
- remove complete flange and from same remove seal ring and ball bearing.
- remove the two gaskets (one between flange and shim and one between shim and drive box).
- remove shim.

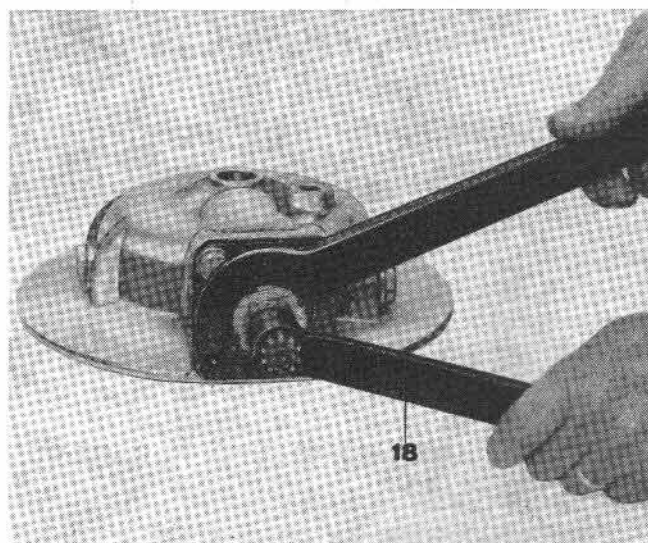

Fig. 85

- remove internally toothed sleeve for rear wheel coupling, c/w bevel crown.
- from internally toothed sleeve, after flattening lock plates and undoing bolts, remove bevel gear crown.
- remove bearing stop screw and plate.
- remove roller bearing cage and inner race.
- remove roller bearing race by means of pulley No. 12906900 (see 2 on Fig. 86).
- remove roller bearing cage retaining ring.
- remove oil seal from drive box.
- remove rear wheel-drive box distance piece.
- remove from drive box filler plug (B) and level plug (A) c/w gaskets (see Fig. 84).

Stripping down of universal double joint, gaiters and bands will only be possible after removal of engine - gearbox group from frame or removal of rear fork.

CHECK AND OVERHAUL OF REAR WHEEL DRIVE ASSEMBLY

REAR WHEEL DRIVE BOX

- box must not show any cracks.
- bearing housing must not be scored or marked.
- contact surfaces must not be scored or marked.
- seal ring must be unimpaired. If burred or without elasticity, replace it.
- always remember to fit new gaskets.

DRIVE BOX FLANGE

- flange must not show any cracks.
- contact surface must not be scored or marked.
- bearing and seal ring housings must not be scored or marked.
- seal ring must be unimpaired. If burred or without elasticity, replace it.

DISTANCE SHIMS

Available in six different thicknesses:

- 0.8 mm. (.0315") - 0.9 mm. (.0354")
- 1.00 mm. (.0393") - 1.1 mm. (.0433")
- 1.2 mm. (.0472") - 1.3 mm. (.0512").

Check that coupling surfaces are not scored or marked.

INTERNALLY TOOTHED SLEEVE FOR REAR WHEEL COUPLING

- surface supporting ball bearing must be flawless and positively smooth.

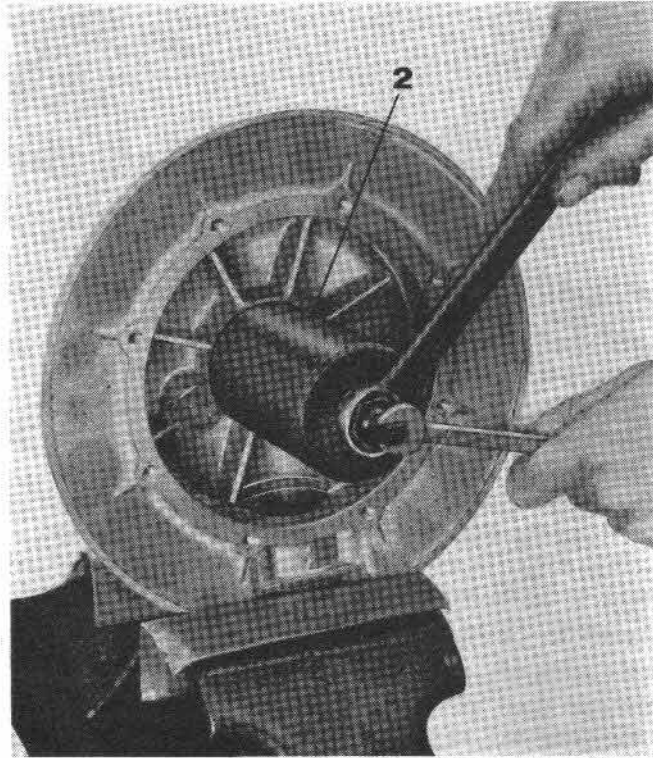

Fig. 86

- internal teeth must not be damaged or marked.

BEVEL GEAR SET

- Bevel gear set consisting of pinion and crown. Teeth must not show any chipping or excessive wear. Pinion shank must be without marks and splines must be smooth, without marks.

CAGE RETAINING RING

- Contact surface must not show any mark or excessive wear. If necessary, replace it.

REAR WHEEL - DRIVE BOX DISTANCE PIECE

Check that contact surfaces are not damaged.

BEARING HOUSINGS

- coupling surfaces must not be scored or marked.
- bearing housings must not be worn or damaged.
- always replace gasket.

ADJUSTING WASHERS

— Contact surfaces must not be damaged.

SHIMS

Coupling surfaces must not be marked or worn out.

BEVEL GEAR DISTANCE PIECE

Surfaces must be very smooth and without scoring.

LOCKRING SAFETY WASHER

If safety tongues are damaged, replace washer.

LOCKRING

Thread must be faultless. If stripped or damaged, replace part.

SEAL RINGS

They must not be burred or lacking elasticity, otherwise must be replaced.

DRIVE SHAFT-BEVEL PINION SLEEVE

Internal splines must be faultless, without chipping or marks. If necessary replace sleeve.

DRIVE SHAFT

Splines must be unimpaired, without chippings or marks. If necessary replace shaft.

DOUBLE JOINT

Internal splines of joint must be smooth, without chipping or marks. Check that articulation is not too slack or too tight. If necessary replace joint.

BANDS

They must be in perfect condition, otherwise replace them.

RUBBER GAITERS

They must not show any crack or loss of elasticity. If necessary replace them.

BALL BEARINGS AND TAPER ROLLER BEARINGS

Bearings must be in perfect condition, without excessive slack. Races must be even and smooth. Balls and rollers must be unimpaired all over their surfaces. If any fault is detected, replace them (see paragraph « Bearings » on page 77).

ASSEMBLING OF REAR WHEEL DRIVE

To assemble rear wheel drive operate in the following sequence:

- replace oil drain plug (see C on Fig. 84).
- insert rear wheel-drive box distance piece.
- press oil seal in drive box.
- fit cage retaining ring.
- fit roller bearing outer race.
- fit roller bearing cage and inner race.
- secure bearing stop screw and plate.
- secure bevel crown to internally toothed sleeve by means of bolts and lock plates (after tightening bolts, remember to bend down lock plates ends).
- press ball bearing and seal ring in box flange.
- position new gaskets on drive box and box flange.
- secure flange to box by means of bolts and lock plates (lock plates ends must be bent down **after** bevel gear adjustment).
- fit into bearing housing: front bearing, distance piece, adjusting washers and rear bearing.
- fit shim and adjusting washers on bevel pinion and insert pinion shank into bearing housing, securing it by lockring and lockring safety washer, using tool No. 12907100 and special wrench (see 18 on Fig. 85). Lockring must be locked by washer tongue after adjustment of bevel gear set.
- secure bearing housing c/w bevel pinion to drive box by means of nuts and washers, after making sure of correct adjustment of bevel gear set.

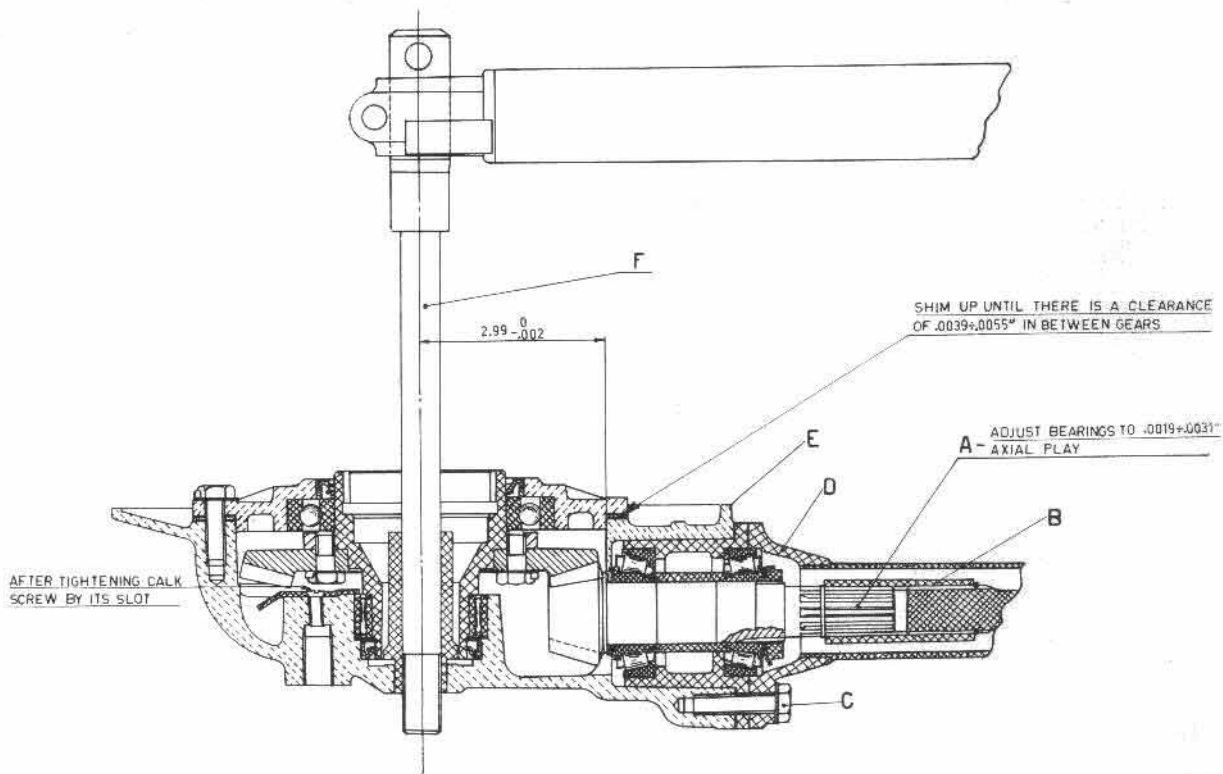

Fig. 87

- fit ball bearing on fork, securing it by circlip.
- now insert double joint in fork ball bearing and fit gaiters over joint, securing them by band on fork side only. Front side of gaiters will be secured only when engine-gearbox group will be assembled to frame.

ASSEMBLING GEAR WHEEL DRIVE TO R/H ARM OF REAR FORK

To assemble rear wheel drive to rear fork operate as follows (see Fig. 87):

- after positioning circlips in drive shaft grooves insert shaft into double joint and shaft bevel drive sleeve.
- insert splined portion of bevel pinion (A) into sleeve (B) and screw up without locking the four bolts and washers (C) securing drive box (E) to rear fork arm (D). Then insert rear wheel spindle (F) thru L/H side arm of rear fork and inside drive box, screw down the four bolts (C) and extract spindle (F). Finally, pour 0.300 lt. (5/8 pints) of Shell Spi-

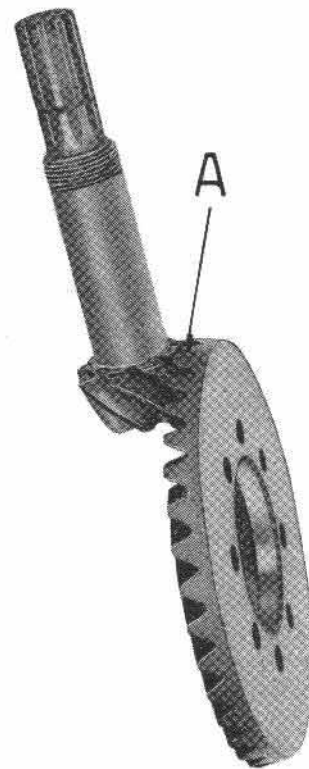

Fig. 88

Fill with 90 E.P. oil into the drive box. Refit level plug A and filler plug B (fig. 84) using new washers.

CONTACT CHECK AND ADJUSTMENT OF BEVEL GEAR TEETH

Give bevel gear set a pinion-crown clearance of 0.10-0.15 mm. (.0039-.0059") and before checking teeth contact make sure of correspondence of planes formed by gear set outer surfaces normal to generating pitch line (see A on Fig. 88).

Teeth contact check is carried out as follows:

- smear crown teeth with lead oxide and then rotate pinion keeping crown braked so that rotation will take place under load and contact marks will appear on painted surface of crown.

Contact is correct when marks left by pinion teeth on crown teeth are even all along flank (see Fig. 89).

Contact between teeth could be incorrect and the following instances might arise:

- 1 - Excessive contact at bottom of tooth flank (see Fig. 90). This means that pinion is too

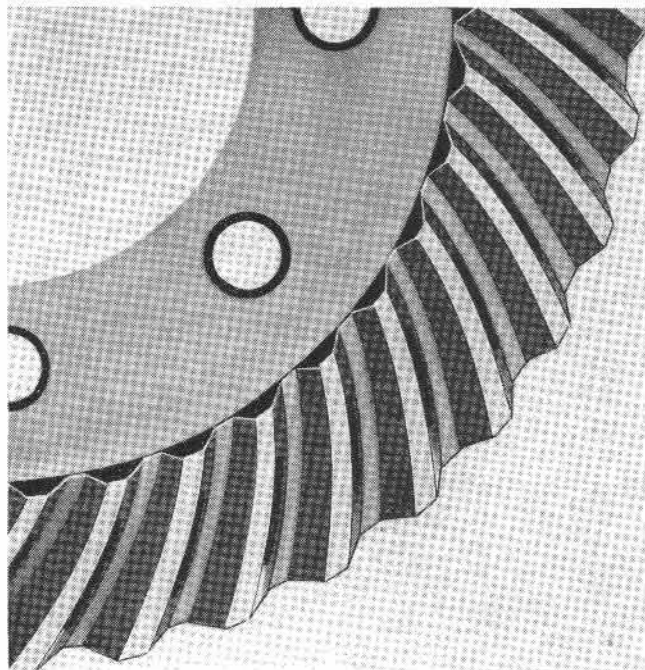

Fig. 90

deeply inserted into crown. Withdraw pinion reducing adjusting shims.

- 2 - Excessive contact at tooth heel (see Fig. 91). This means that crown is too far apart from pinion. Approach crown to same adopting an o/s shim.

- 3 - Excessive contact at tooth crest (see Fig.

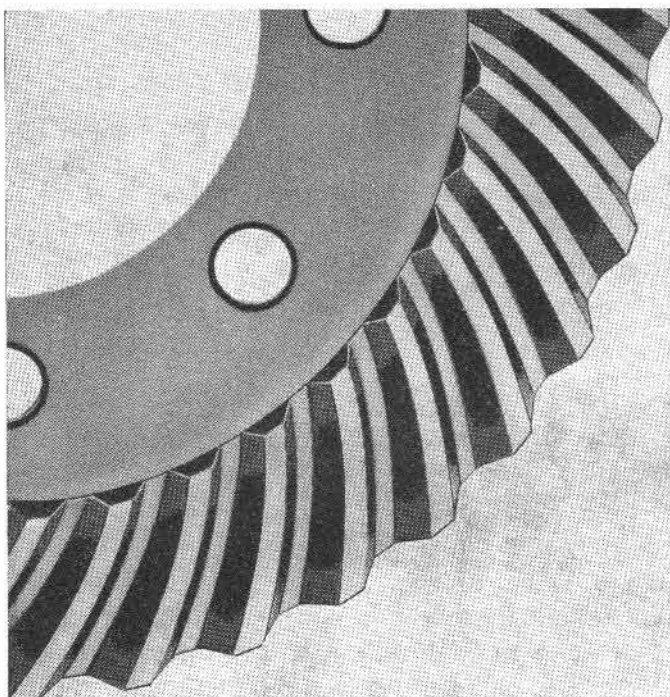

Fig. 89

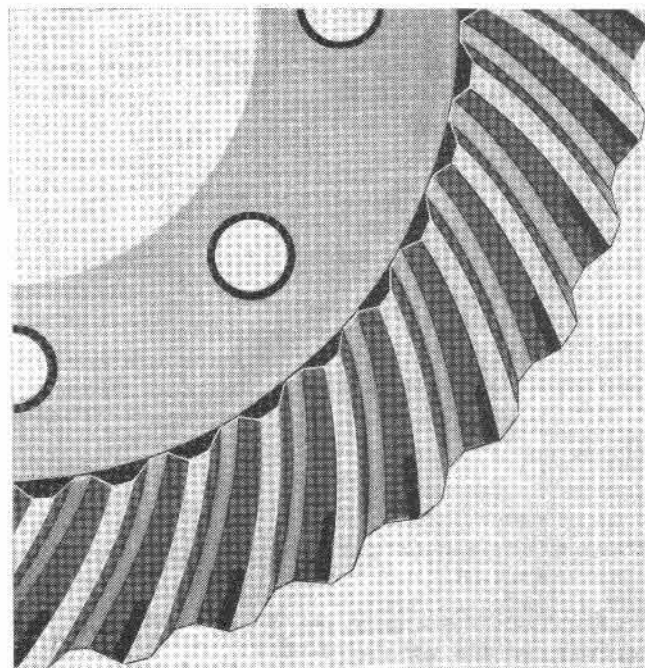

Fig. 91

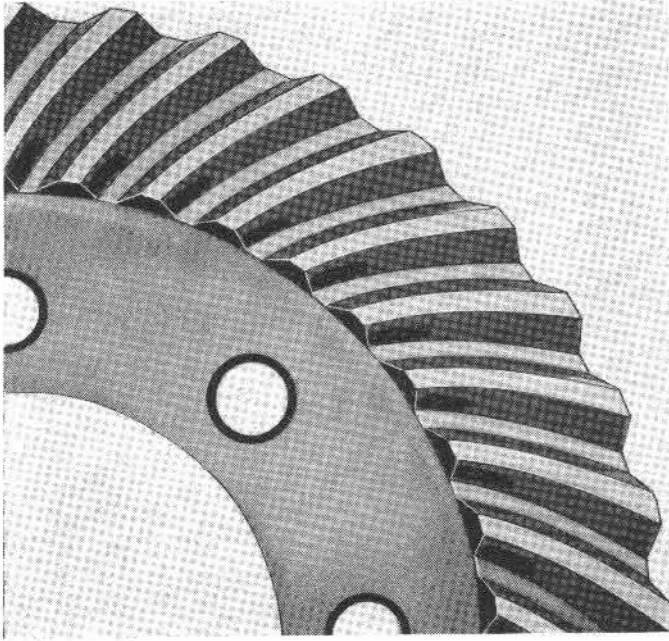

Fig. 92

92). This means that pinion is too far apart from crown. Approach pinion to same increasing adjusting shims.

4 - Excessive contact at top land (see Fig. 93).

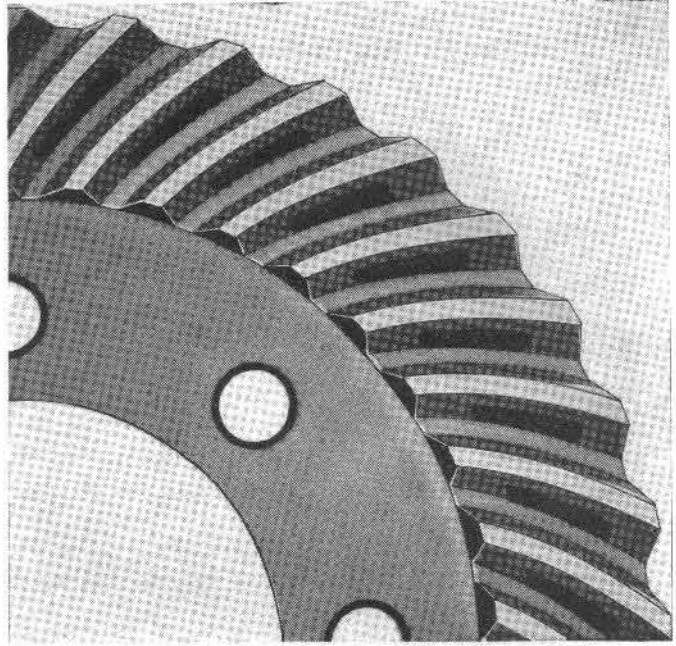

Fig. 93

This means that crown is too close to pinion. Move it away adopting u/s shim. After any of the above operations it will be necessary to re-set correct pinion-crown clearance.

REAR SUSPENSION

STRIPPING FROM FRAME

Unscrew nuts and remove suspensions from bosses on frame, rear fork and drive box.

CHECK AND OVERHAUL

Check suspension efficiency. If not normal, providing this is not due to imperfect operation of shock absorbers within, check spring load (see Fig. 94).

FITTING UP ON FRAME

Position suspensions in bosses on frame, rear fork and drive box and secure them by means of nuts and washers.

Adjust suspensions to desired position (1-2 or 3) using special wrench No. 12912700 (see 6 on Fig. 95).

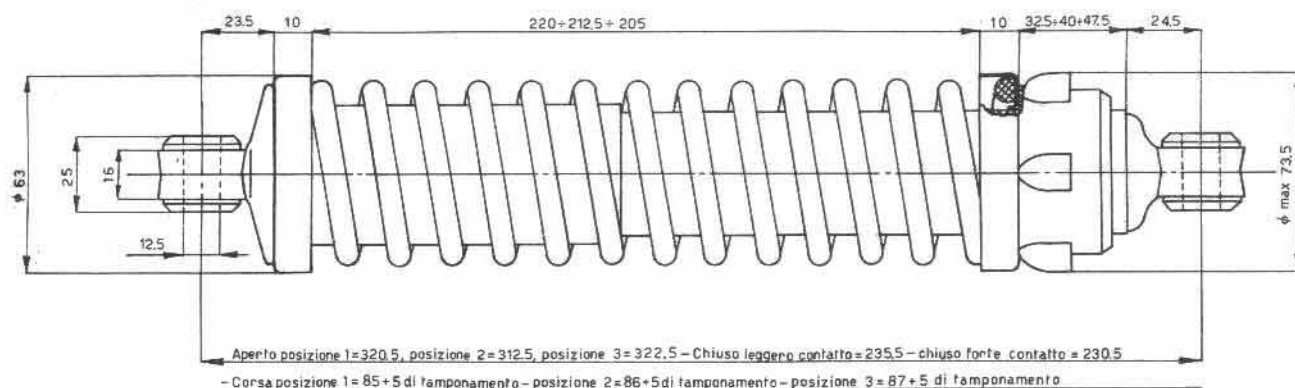

Fig. 94

Position 1:

Springs compressed at 220 mm. (8.66") must show a load of 57 Kgs. (125.6 lbs.).
At 135 mm. (5.31") load must be 184-191 Kgs. (405-421 lbs.).

Position 2:

Springs compressed at 212.5 mm. (8.36") must show a load of 68 Kgs. (149.9 lbs.).
At 126.5 mm. (4.97") load must be 192-202 Kgs. (423-445 lbs.).

Position 3:

Springs compressed at 205 mm. (8.06") must show a load of 79 Kgs. (174 lbs.).
At 118 mm. (4.65") load must be 206-213 Kgs. (454-469 lbs.).

Should loads be found to be below 96% of above figures, springs will need to be replaced. If imperfect operation is due to shock absorbers, it is suggested to apply directly to manufacturer of same.

FLEXIBLE BUSHINGS

Check that they are not burred or lacking flexibility.

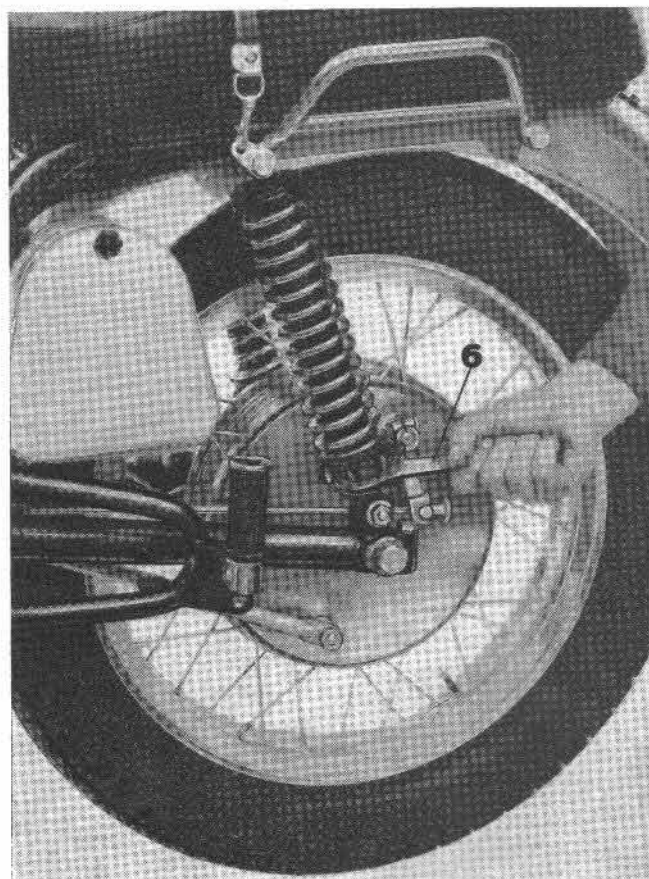

Fig. 95

FRONT SUSPENSION AND STEERING

STRIPPING

To strip down handlebar, front fork and steering operate as follows:

- remove handlebar, after disconnecting control cables, undo clamp screws and remove clamp caps.
- undo screws which secure instrument panel, disconnect electric cables and speedo drive from speedometer.
- remove instrument panel, after removal of the 4 screws which secure same to fork top linking plate.
- remove speedometer from instrument panel.
- from top linking plate remove nut and fork top plugs.
- remove top linking plate, by means of ring wrench and tool No. 60910500 (see 3 on Fig. 96).
- remove steering tube lockring (B) and lock cap (A) as shown on Fig. 97.
- undo bolts securing bottom yoke to fork rods.
- remove bottom fork covers c/w fork rods and spring housings, avoiding to spill the oil contained inside.

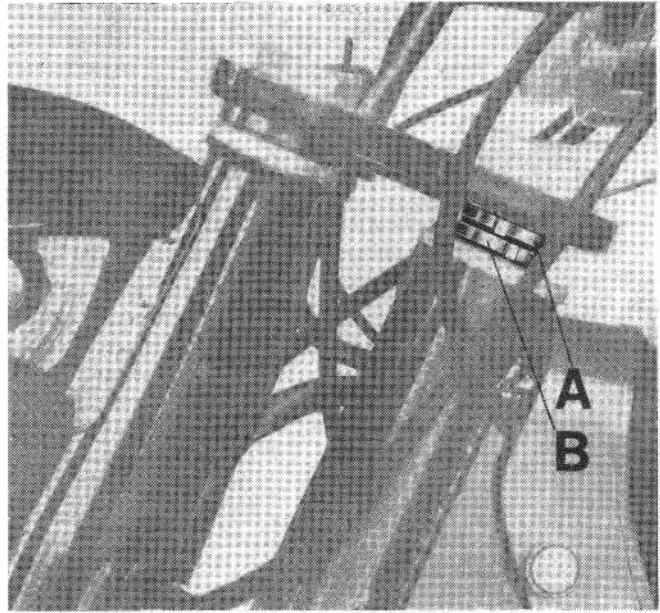

Fig. 97

- drain oil from dampers (after stripping down fork, oil can be drained by removing drain plugs (see A on Fig. 98) from both fork covers).



Fig. 98

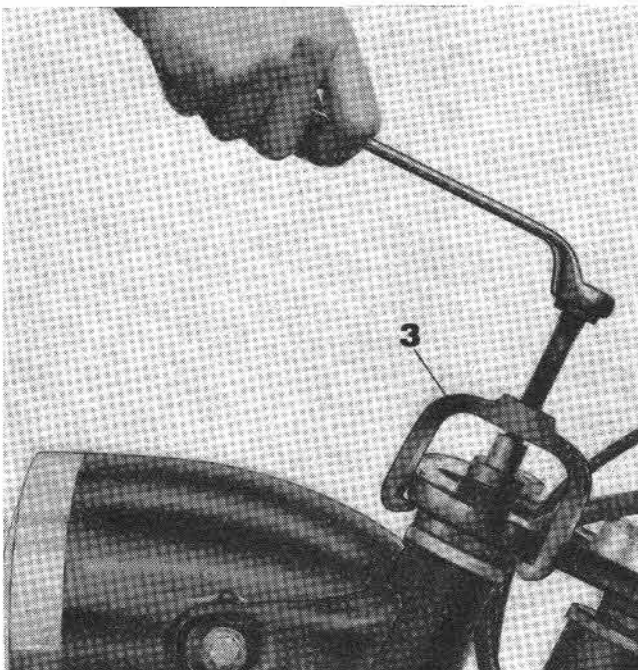

Fig. 96

- remove spring housings and springs.
- remove headlight bracket bottom plate.
- remove spring housings.
- from spring housing remove seal ring and rubber ring.
- remove circlip and adjusting washer.
- remove fork cover c/w bush.
- remove bottom link bush locking and extract bush.
- after undoing nut, remove bottom yoke steering tube.

- Rod-bottom bushing fitting clearance:
0.020 - 0.044 mm. (.0007-.0017")

TOP BUSHING

Surfaces must be without any scoring or marks.
Stroke 120 mm. (4.7244")

- I/D: 34.760 - 34.800 mm. (1.3685-1.370")
- O/D: 40.010 - 39.971 mm. (1.5751-1.5735")

OVERHAUL OF TELESCOPIC FRONT FORK AND STEERING

Check C/Ls distance (see Fig. 99).

BOTTOM BUSHING

Surfaces must be without any scorings or marks.

- I/D: 34.700 - 34.739 mm. (1.3661-1.3676")
- O/D: 39.950 - 39.911 mm. (1.5728 - 1.5712").

FORK RODS

Check that chromium plated portion of fork rod sliding inside bushings is without scoring or marks. Rods must be perfectly straight and thread must be in perfect condition.

- Rod diameter at chromium plated portion:
34.720 - 34.695 mm. (1.3669-1.3659")
- Rod-top bushing fitting clearance:
0.040 - 0.105 mm. (.0015-.0041")

FORK BOTTOM COVERS

Check that inner surface is perfectly smooth, without scorings or marks.

- I/D of cover 40.010 - 40.050 (1.5751-1.5767")
- cover-top bushing fitting clearance:
0 - 0.079 mm. (0.-.0031")
- cover-bottom bushing fitting clearance:
0.099 - 0.100 mm. (.0038-.0039")

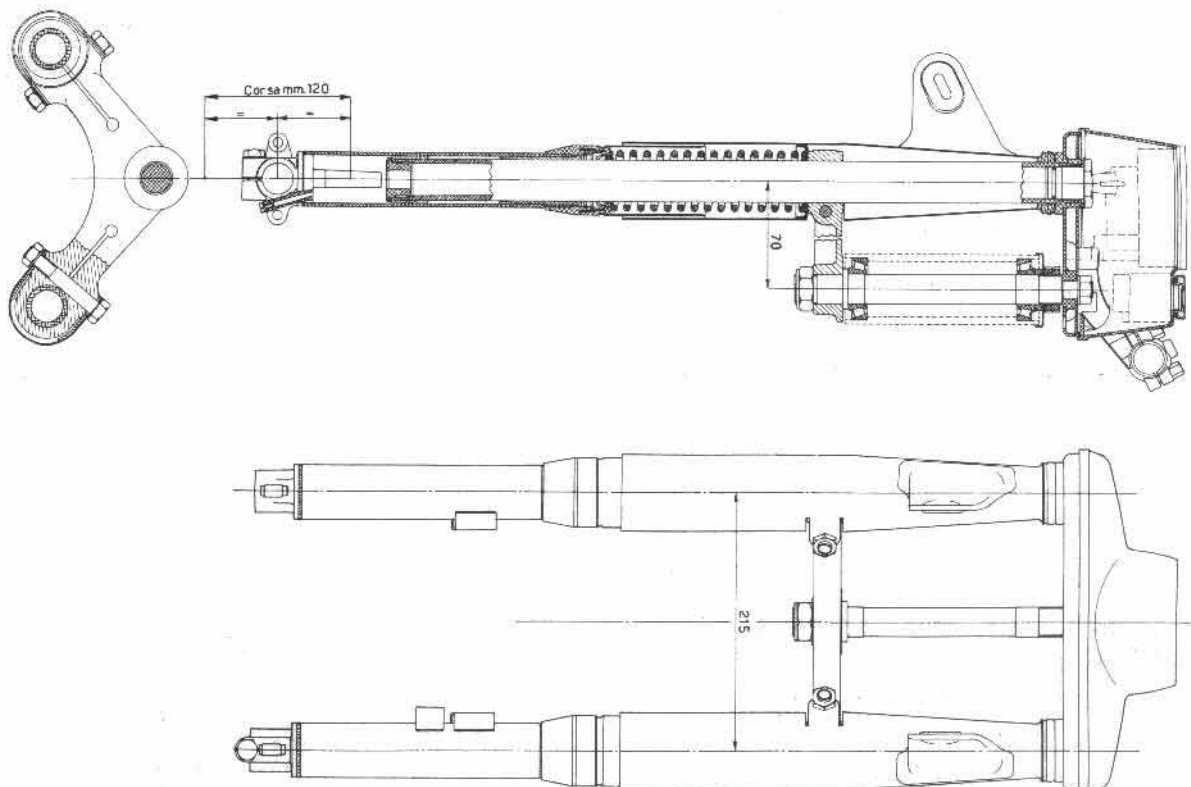

Fig. 99

FORK SPRINGS

Check that springs are not deformed or cracked. Length of new spring at rest is 230 ± 15 mm. (9.0551"). Required load for compressing spring down to 170 mm. (6.6929") is 50 ± 2 Kgs. (110 \pm 4 lbs.), while 105 ± 3.5 Kgs. (231 — 8 lbs.) will be required to compress spring down to 104 mm. (4.0945").

With spring at rest, check its length reduction. If same is more than 3%, replace spring.

SPRING HOUSINGS

Remove seal ring and gasket and check perfect condition of same. If burring, wear or lack of elasticity is detected, replace part.

TOP PLUG RUBBER RINGS

Check that they are in perfect condition, otherwise replace them.

TOP PLUG SEALS

Check that rubber is not burred, worn or lacking elasticity. If necessary replace part.

STEERING TAPER ROLLER BEARINGS

Bearings must be in perfect condition, without excessive slack. Races must be perfectly even and smooth. Rollers must be unimpaired all over their surfaces. If any fault is detected, bearing must be replaced. (see paragraph « Bearings » on page 77).

STEERING ADJUSTING LOCKRINGS

Check that they are not cracked and that threads are in perfect condition, otherwise replace them.

STEERING TUBE

Check that threaded portions of tube are unimpaired, not damaged or marked.

ASSEMBLING FORK AND STEERING ON FRAME LUG

To assemble fork and steering in frame lug operate as follows:

— fit top and bottom bushings on fork cover and secure bushing lockring.

- fit fork rod c/w fork bottom covers.
- position adjusting washer in top part of cover and then fit circlip in cover groove.
- position gasket fork cover and spring housing.
- after pressing in seal ring, fit spring housing, by means of special wrench No. 12912600 (see 11 on Fig. 100).
- fit spring over fork rod, positioning same in spring housing.
- insert fork rod in bottom yoke and headlight bracket, positioning it by means of tool No. 12909500 previously connected to fork rod (see 4 on Fig. 101).
- fit clamp bolt and secure headlight bracket.
- secure steering tube to bottom yoke by means of suitable nut.
- fit drain plugs and gaskets on both fork covers.
- pack steering bearings with grease and fit them in frame lug, then insert steering tube inside frame lug.

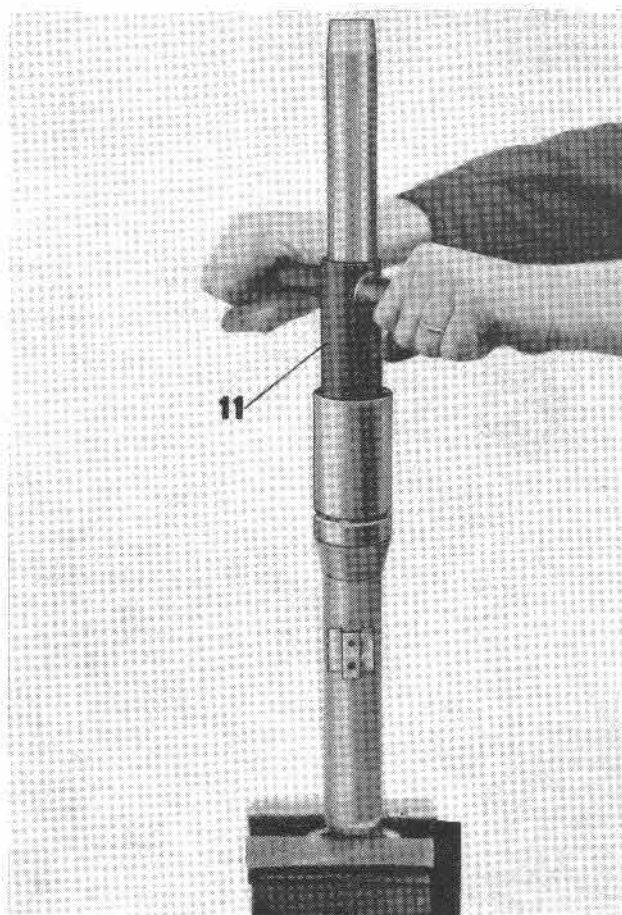

Fig. 100

- fit steering tube cap.
- fit steering tube lockring (see B on Fig. 97) and adjust steering play. Then secure lock cap (see A on Fig. 97) by means of special wrench.
- position rubber rings and caps in headlight brackets, and then fit top linking plate.
- thru filling plug (see B on Fig. 98) pour into each fork tube 0.160 liters 5.4 oz.) of « SHELL Tellux 33 » oil.
- fit top fork plugs and washers, previously positioning plug seals.
- fit linking plate washers and screw down nut securing top linking plate to steering tube.
- secure handlebar clamps to top linking plate, by means of screws and washers.
- fit speedometer on instrument panel, after connecting all electric cables and speedo drive .
- secure instrument panel to top linking plate by means of screws.
- fit handlebar on clamps by means of clamp caps and screws.



Fig. 101

STRIPPING OF REAR SWINGING FORK

After removal of rear wheel drive, operate as follows:

- remove cap nuts from fork support spindle.
- remove lock nuts from fork support spindle.
- remove fork support spindles, using special wrench.
- remove spacers.
- remove seal rings.
- remove the two roller bearings. To pull outer races from fork, use tool No. 12904700 (see 1 on Fig. 102).

OVERHAUL OF REAR FORK

Check that rear fork has not got any abnormal bending or misaligned part. Bearing housings must be in good condition and flange surface contacting drive box must be even and smooth. Check measures on Fig. 103.

NUTS AND LOCKNUTS

Check that thread is unimpaired, without any damage .

SUPPORT SPINDLES

Check that thread is unimpaired, without any damage.

SEALS

Check that they have not lost elasticity and are not burred.

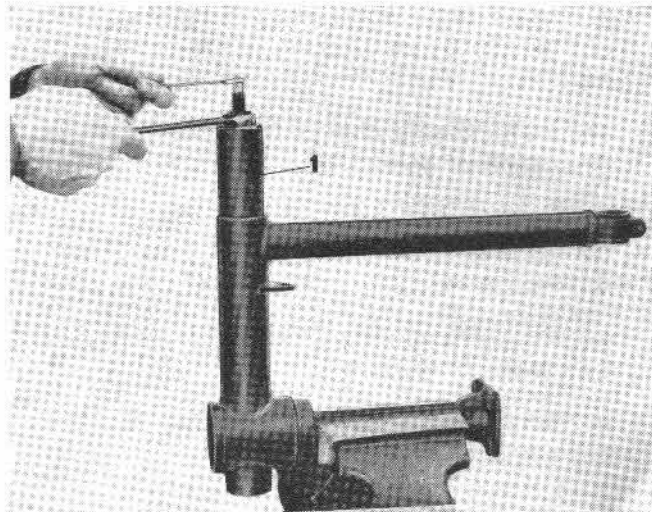

Fig. 102

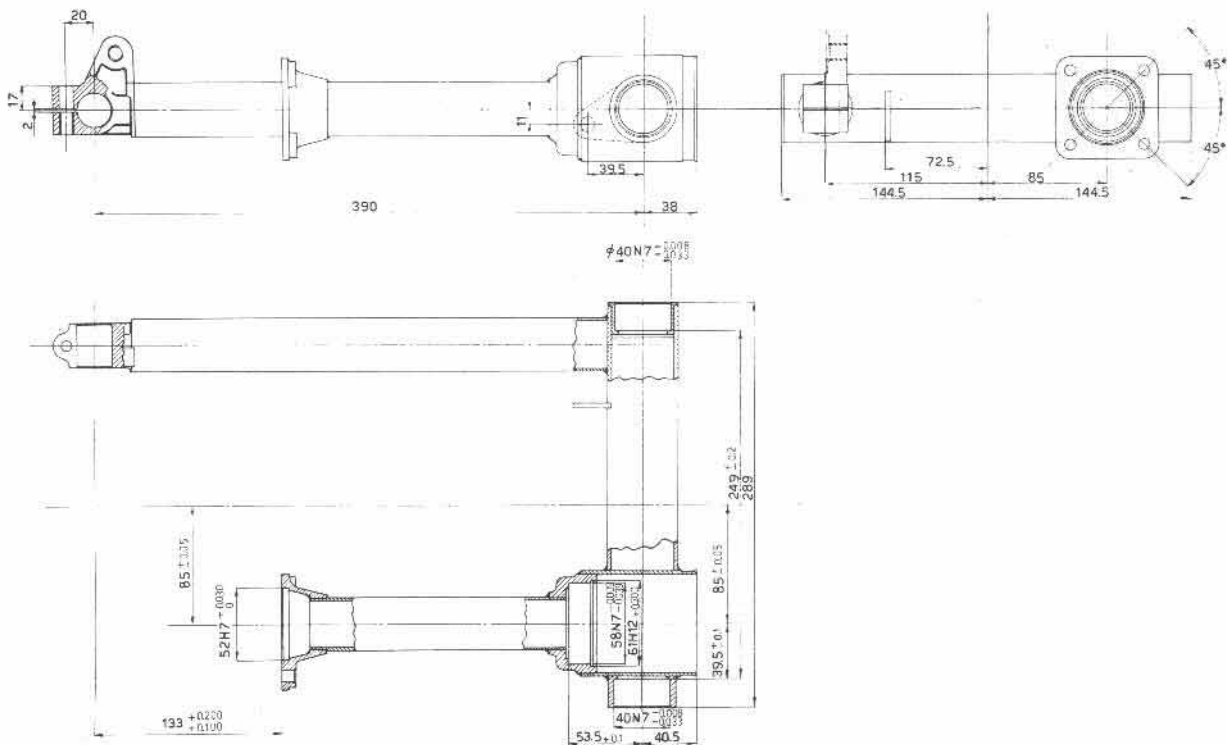

Fig. 103

BALL BEARINGS AND TAPER ROLLER BEARINGS

Bearings must be in perfect condition, without excessive slack. Races must be perfectly even and smooth. Rollers and balls must be unimpaired all over their surface. If any fault is detected, bearing must be replaced (see paragraph « Bearings » on page 77).

FITTING UP REAR FORK

Fitting up is carried out as follows:

- press taper roller bearings in their housings.
- press in the two seal rings.
- position spacers.
- fit fork on frame.
- insert support spindles.
- tighten locknuts allowing fork to swing freely. Use special wrench No. 12903000 (see 13 on Fig. 104) and open wrench to hold locknut.

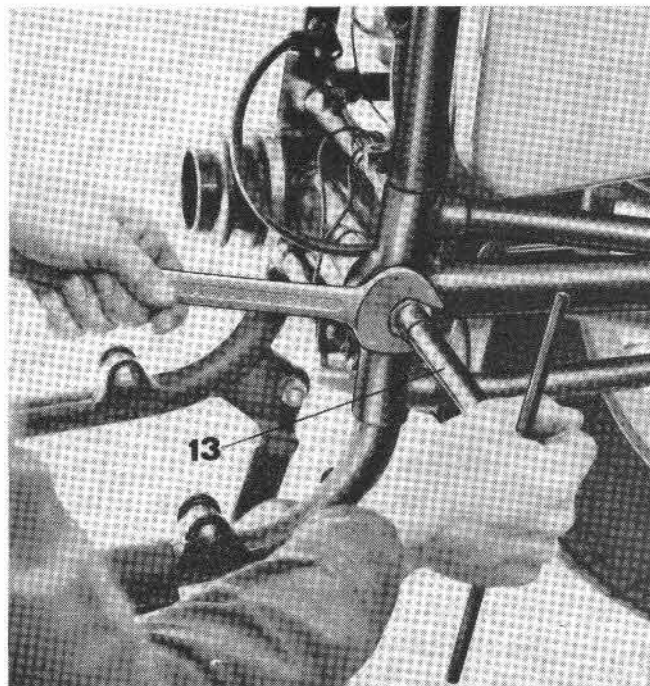

Fig. 104

WHEELS AND BRAKES

FRONT WHEEL (see Fig. 105)

To remove wheel from front fork operate as follows:

- disconnect front brake cable from brake lever on hub cover (A) and unscrew cable adjuster (B).
- undo nut (C) which secures wheel spindle to R/H fork bottom cover and also undo wheel spindle locking bolt (D).
- take out wheel spindle.
- push wheel downwards just enough to free hub cover from anchoring lug on L/H fork bottom cover, then remove wheel.

To strip down wheel hub, operate as follows:

- remove complete hub cover.

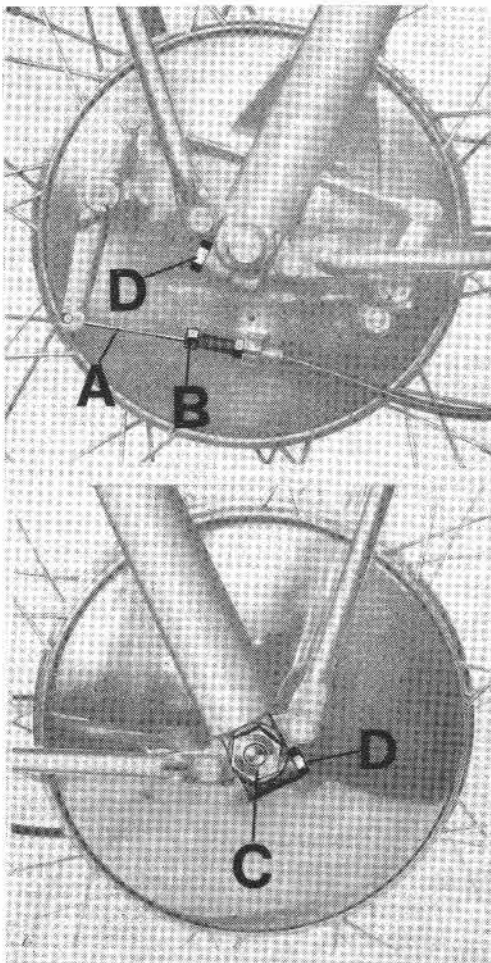

Fig. 105

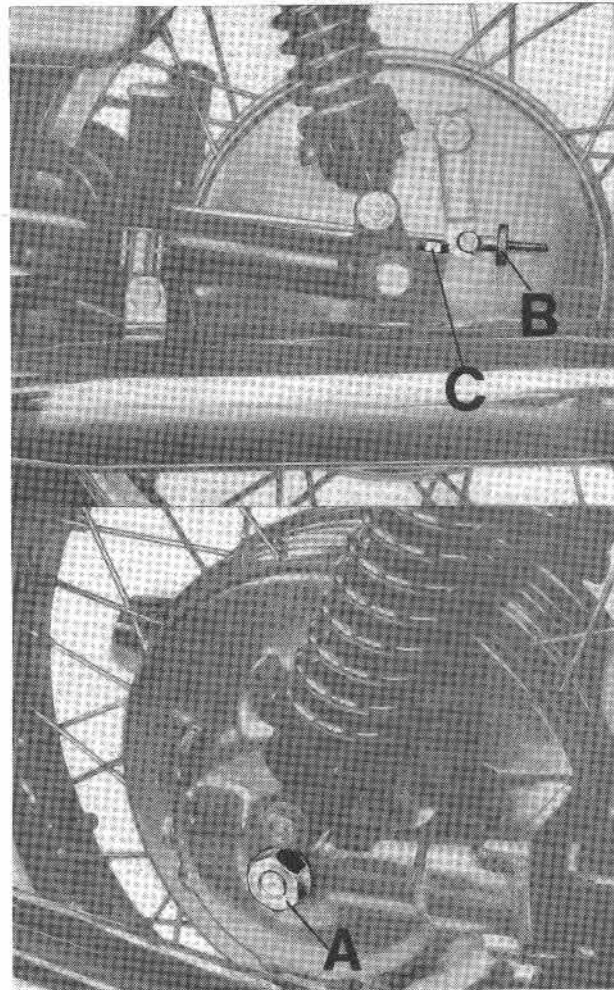

Fig. 106

- after undoing bolts which secure lever to cam, remove levers and rod from hub cover.
- remove brake shoes, cams and brake shoe pins.
- from L/H hub cover remove the following: seal ring, bearing housing, taper roller bearing, adjusting washers and distance piece.
- from R/H hub cover remove the following: seal ring, bearing housing and roller bearing.

REAR WHEEL (see Fig. 106)

To remove rear wheel from rear fork and drive box operate as follows:

- unscrew nut (A) which secures wheel spindle to drive box.
- unscrew nut which secures brake block to anchoring lug.
- undo rear brake adjusting thumb screw (B)
- remove bolt (C) which locks the spindle to rear fork, and take out wheel spindle.

- push the wheel on the left just enough to free central body of same from internally toothed sleeve in drive box.
- tilt machine on R/H side and take out wheel.

To strip down rear wheel hub, operate as follows:

- remove complete hub cover.
- after undoing bolts which secures lever to cam and nut on shoe pin, remove from hub cover brake shoes and take out cam and shoe pin.
- from L/H hub cover remove the following: seal ring, bearing housing, taper roller bearing, adjusting washers and bearings spacer.
- from R/H hub cover remove the following:

seal ring, bearing housing and taper roller bearing.

- remove central body, after undoing the six bolts which secure same to wheel hub.

Wheels and brakes check

WHEELS

Check wheel truing and if any spoke is broken or has got a stripped thread, replace. When fitting new spokes, wheel truing will have to be re-checked operating as follows: clamp into a

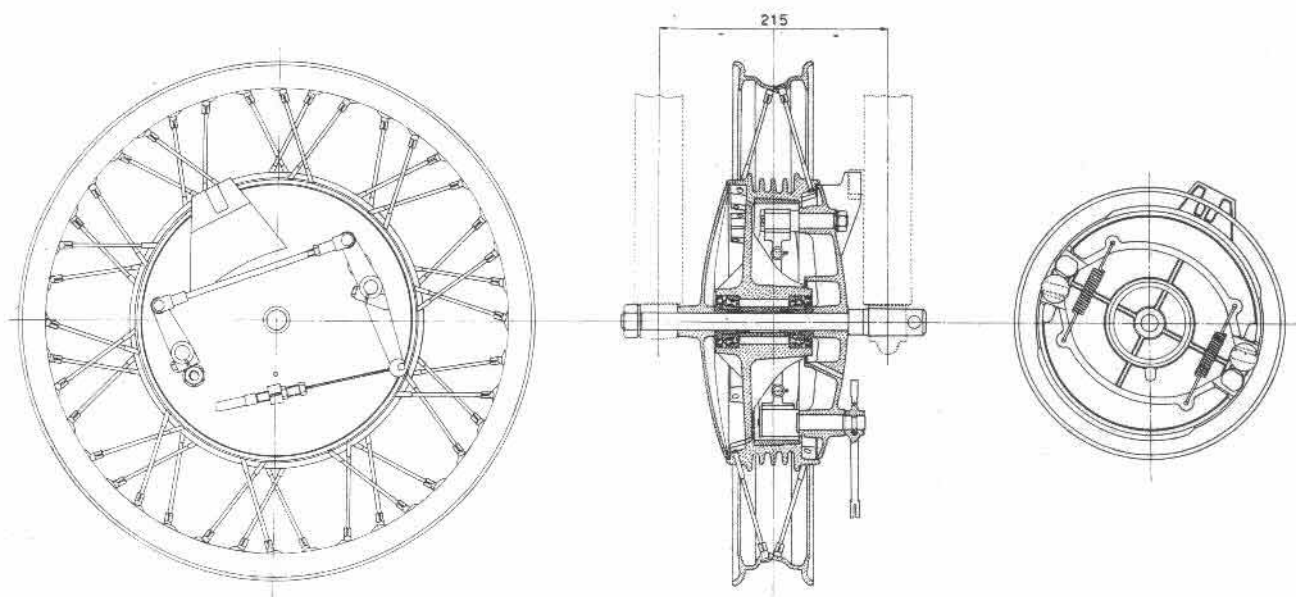

Fig. 107

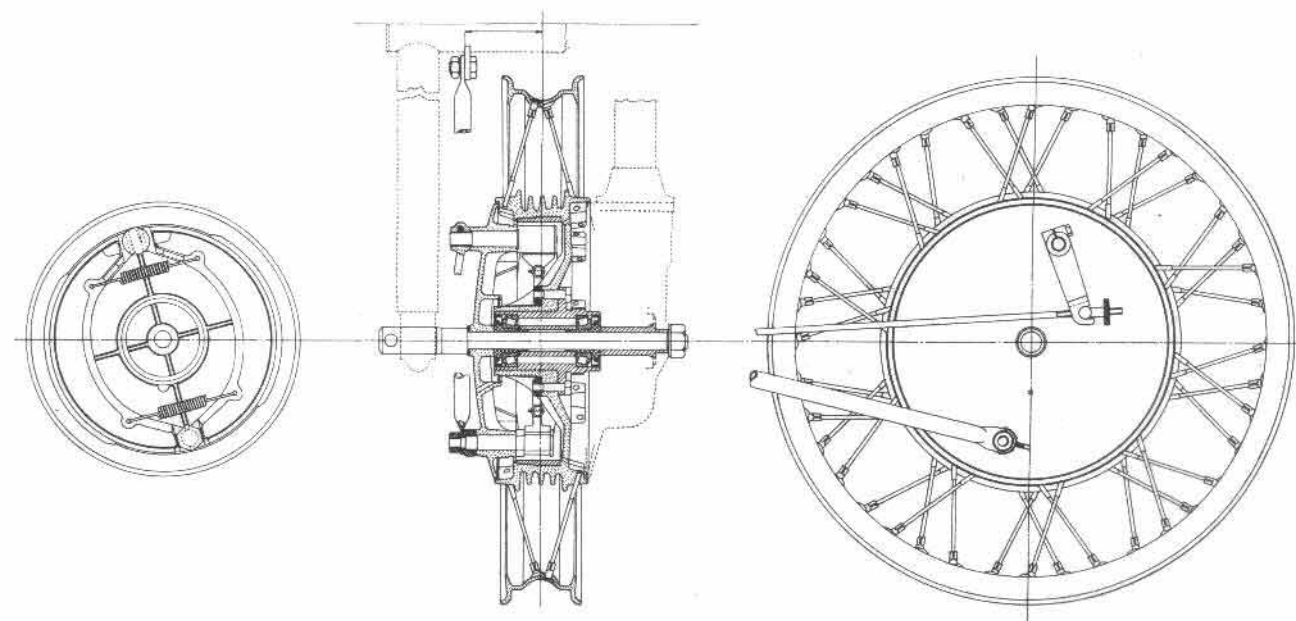

Fig. 108

vice the suitable fork made for this purpose, then position wheel on fork and rotate same checking peripheral shiftings, both in radial and axial sense. To eliminate radial shiftings, if any, it will be necessary to tighten or loosen the spokes (both R/H and L/H) near the point of maximum shifting. To eliminate axial shiftings it will be necessary to tighten R/H spokes and loosen L/H ones (near shifting point), or viceversa.

True wheels on front fork and rear fork referring to Fig. 107 for front wheel and Fig. 108 for rear wheel.

RIMS

Check that rims have no deep marks or cracks otherwise replace.

SPOKES

Check that no spoke is broken or has got a stripped thread. If necessary replace and re-set wheel truing as described on paragraph « Wheels ».

BRAKE SHOE LININGS

Check that linings are not too worn out, cracked or greasy. Thickness of new linings is about 5 mm. (.1968"). If same is found to be below 2.5 mm. (.0984") linings must be replaced. If linings are only greasy on surface, clean with pure gasoline and recondition using a wire brush. If deeply greased or showing cracks or cuts, replace them.

BRAKE SHOE SPRINGS

Check that springs are not deformed or lacking elasticity. Front brake shoe spring, under a load of 21 kgs (46.2 lbs), must extend to 98 mm. (3.8583"). Rear brake shoe spring, under a load of 60 kgs (132.2 lbs), must extend to 98 mm. (3.8583"). Load allowance: about 5%.

BRAKE SHOE CAM

Check that surface of cam stem is very smooth and that splined end does not show any mark. Also check that cam surface is not too worn out. If necessary, replace part.

BRAKE SHOE PINS

Check that surface contacting shoes is smooth, without scoring or marks, and check that thread is in perfect condition.

BRAKE DRUMS

Check that inner surface of drum, where brake shoes operate, is not scored. Slight scoring can be eliminated by smoothing surface with emery cloth, but should scoring be very deep, drums will have to be turned. In front wheel brake drum check that taper roller housings are smooth, without marks.

REAR WHEEL CENTRAL BODY

Check teeth which is coupled to internally toothed sleeve in rear wheel drive box. Teeth must be unimpaired, without chipping or marks, and taper roller bearing housings must be without scoring or marks.

HUB SEALS

Check that seal rings are not burred or lacking elasticity, and if necessary replace them.

TAPER ROLLER BEARING HOUSINGS

Check that surface on which bearing is pressed is without scoring or marks and that contact ends are unimpaired.

TAPER ROLLER BEARINGS

Bearings must be in perfect condition, without excessive slack. Races must be perfectly even and smooth. Rollers must be unimpaired all over their surfaces. If any fault is detected, bearings must be replaced (see paragraph « Bearing » on page 77).

ADJUSTING WASHERS

Check that faces are smooth, without scoring or marks, otherwise replace washer.

BRAKE CAM LEVER

Check that inner splines are smooth, without marks.

FRONT BRAKE CABLE

Check that cable and sheathing are in good condition, otherwise replace them.

FRONT BRAKE ADJUSTMENT (see Fig. 109)

The lever is correctly adjusted when there is about 20-25 mm. ($\frac{3}{4}$ to 1") play at the lever tip before the linings contact the drum. To adjust undo thumb screw (A) and operate on adjuster (B) to obtain correct play. This adjustment can also be made acting on adjuster (C) and nut (D) situated on front hub cover.

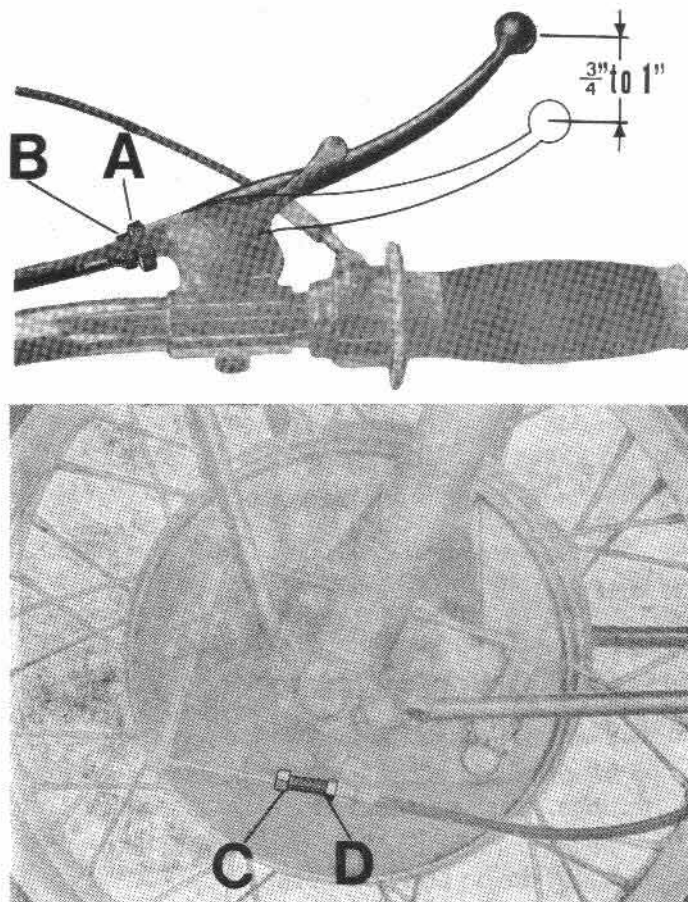

Fig. 109

REAR BRAKE ADJUSTMENT (see Fig. 110)

The lever is correctly adjusted when there is about 20-25 mm. ($\frac{3}{4}$ to 1") play at pedal end (B) before the linings contact the drum. To adjust operate on thumb screw (A) fitted on the threaded portion of brake rod. Generally, when adjuster reaches the end of rod threaded portion it means that shoe linings are completely worn out.

ASSEMBLING OF WHEELS

After having carried out the different checks, overhauls and replacements, assemble all parts on wheel hubs and secure complete wheels to front fork and rear fork.

ASSEMBLING OF FRONT WHEEL HUB

To assemble front wheel hub operate as follows:

- fit following parts on R/H hub cover: taper roller bearing, bearing housing and seal ring.
- fit following parts on L/H hub cover: bearings distance piece, adjusting washers, taper roller bearing, bearing housing and seal ring.

If end play is excessive, remove one adjusting washer, while if wheel does not rotate freely it will be necessary to increase washers.

- fit hub cover, after positioning the following parts: brake shoes, cams, shoe pins, levers and rod. If excessive rod play is noticed, disconnect rod from double acting lever, undo adjusting nut and screw up fork on rod just enough to take up play. Re-lock nut and connect rod fork to lever by means of pin and cotter pin.

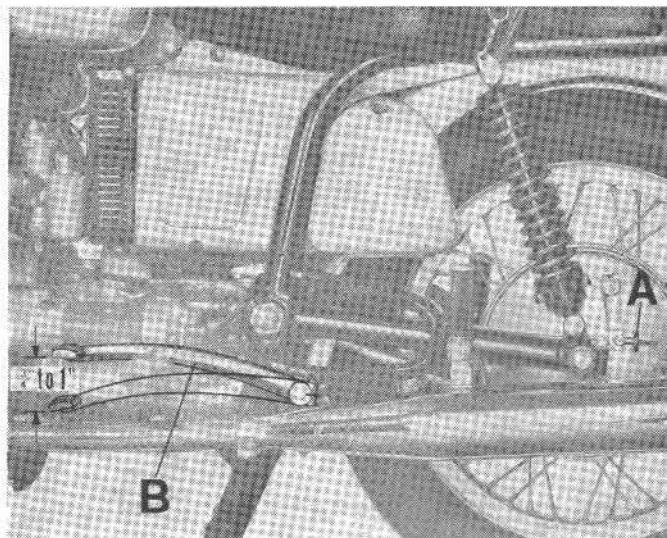

Fig. 110

FITTING FRONT WHEEL ON FORK

(see Fig. 105)

To fit front wheel on front fork operate as follows:

- insert complete wheel between fork members, making sure that hub cover stay is anchored to lug on L/H fork bottom cover.
- insert wheel spindle thru L/H fork bottom cover, wheel hub and R/H bottom cover.
- screw down locking bolt (D) on L/H fork bottom cover and nut (C) on R/H fork bottom cover.
- screw cable adjuster (B) on hub cover and connect front brake cable to brake lever on hub cover.

ASSEMBLING OF REAR WHEEL HUB

To assemble rear wheel hub operate as follows:

- secure central body to hub by means of six bolts, washers and nuts.
- fit taper roller bearing, bearing housing and seal ring on L/H hub cover.

If end play is excessive, remove one adjusting washer, while if wheel does not rotate freely it will be necessary to increase washers.

- fit hub cover, after positioning the following parts: shoe pin, cam and brake shoes.

FITTING REAR WHEEL ON FORK AND DRIVE BOX (see Fig. 106)

To fit rear wheel on swinging fork and drive box operate as follows:

- tilt machine on R/H side and insert complete wheel, engaging central body teeth with internally toothed sleeve in drive box.
- insert rear brake control in cam lever on hub cover, position pin and adjusting thumb screw (B).
- insert wheel spindle thru L/H fork arm, wheel hub and drive box.
- secure anchor rod to hub cover and rear fork, by means of bolts, washers and nuts.
- screw up bolt (C) on L/H fork arm and tighten dead.
- fit nut (A) and washer, securing wheel spindle to drive box.

BALL BEARINGS AND TAPER ROLLER BEARINGS

All ball bearings and taper roller bearings used in this machine are generously dimensioned for longer life.

Inspection:

Examine very carefully outer raceway of inner ring and inner raceway of outer ring. Raceways must be perfectly smooth and glossy. Should any crack or surface imperfection be detected, complete bearing must be replaced. Balls and rollers must be unimpaired and positively smooth all over their surface. If any fault is detected, replace bearing. Never try a partial

replacement because it is extremely difficult to get a good result from repaired bearings. When fitting bearings, pressure must only be applied to the ring which is going to be coupled to housing or shaft.

Bear in mind that new bearings, before being pressed into housing or onto shaft, show a slight backlash (in the range of thousandths of mm. only). Such backlash will diminish after bearing is fitted, but nevertheless it must not disappear completely, otherwise balls or rollers would work under stress and bearing would then rapidly deteriorate. In journal bearings or thrust bearings it is allowed a sensible end play (hundredths of mm.).

ELECTRICAL EQUIPMENT BATTERY

FEATURES

Tension: 12 V
 Capacity: 32 Ah
 Length: 230 mm. (9.0551")
 Width: 139 mm. (5.4724")
 Height: 180 mm. (7.0866")
 Weight: about 13 kgs (28.6 lbs)
 (electrolyte included)
 Battery is located in central part of machine
 (see Fig. 112).

INSPECTION AND MAINTENANCE

Access to the battery is made possible by removing the two battery covers. To remove battery, undo nuts of the two securing studs and remove bracket which secures same to frame.

CLEANING

Battery must always be kept clean and dry, especially on its top part. Clean using a hard brush. Cleaning operation is better carried out keeping the cell plugs fitted, to prevent any impurity from entering the electrolyte. Check that there are no cracks in the sealing compound of the single cells (and consequent leaks). Eliminate leaks, if any, because electrolyte always causes corrosion of any material it might contact.

CHECK AND SMEARING OF TERMINAL BLOCK

Cable terminal locking nuts must always be tightened or loosened by means of suitable open ended wrench. Never hit the cable terminals in order to ease the fitment or removal of same from battery terminal blocks, because such stress could originate leaks in battery lid or detachment of terminal blocks, thus causing electrolyte leaks as mentioned above. Should

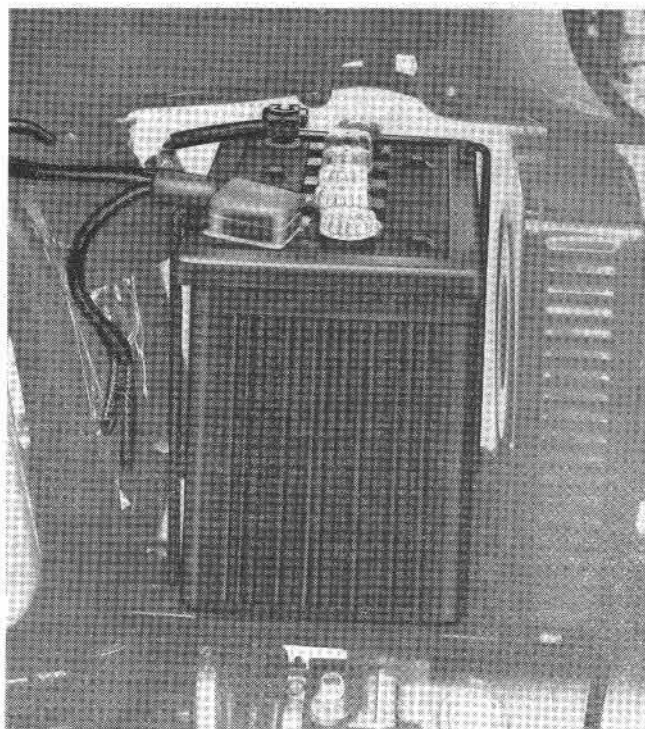

Fig. 112

cable terminals or cables be deteriorated, they must be positively replaced.

After thorough cleaning, cable terminals and terminal blocks must be smeared with pure vaseline jelly in order to prevent oxidation. Smear with particular care the bottom parts of cable terminals and terminal blocks, where electrolyte is more likely to be present.

For this purpose never use lubricating grease. After cleaning and smearing with vaseline, secure cable terminals to terminal blocks very tightly, in order to reduce contact resistance.

ELECTROLYTE LEVEL

Water is the only component of the electrolyte which is subject to consumption. Always top up level with distilled water only, never with sulphuric acid. Every 3000 kms (1800 miles) or 25 hours of effective running (or even more often, especially during the hot season) check electrolyte level in each cell and if necessary

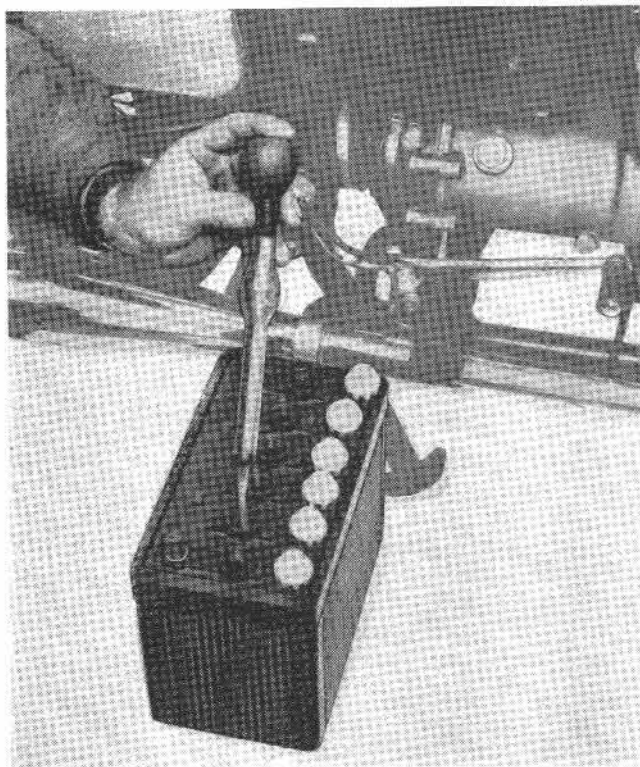

Fig. 113

top up with distilled water. This must be done when battery is cold and it has not been in use for 5-6 hours. Correct level is attained when electrolyte tops the plate separators by about 5 mm. (3/16").

Bear in mind that distilled water container, funnel, tubes, spouts, etc. must be in glass or plastic. In any case they must be perfectly clean. Make sure that distilled water does not get in touch with any metal container.

CHARGE CHECK

To find out charge condition of a battery it is necessary to measure the density of the electrolyte. Never use a fork type voltmeter because this instrument would cause a high discharge spark which, besides damaging the tested cell would also involve a remarkable energy absorption.

Charge condition is checked by means of a hydrometer (see Fig. 113) at a room temperature of about 25° C (77° F).

Density can be read at floating point of hydrometer, keeping the instrument perfectly vertical and checking that hydrometer can float freely on electrolyte. After reading, pour electrolyte back in the same cell from which it had been sucked.

Density sp. gr.	Battery charge in %
1.28	100% - Normal service
1.25	75% - Service in tropical conditions
1.22	50%
1.19	25%
1.16	Nearly discharged (normal service)
1.11	Nearly discharged (tropical conditions)

When battery is nearly discharged (that is to say when density is 1.16 for normal service and 1.11 for tropical conditions) it will be necessary to charge same with an intensity of 4A. If the machine is kept out of use for a long time, the battery should be given a charge every 30-40 days, otherwise it would quickly deteriorate.

BATTERY FAULTS

FAULTS EXAMINATION

Diagnosis of battery faults requires a long specific experience. However we will list here below the main causes which may affect battery life, and main operation irregularities.

FACTORS WHICH REDUCE BATTERY LIFE:

Overcharge

Overcharge (excessive intensity or far too long charge period) will cause the following faults:

- decomposition of water from electrolyte. Besides requiring more frequent top-ups to restore level, this will also cause melting and dripping of paste, due to gas formations.
- corrosion of positive grids and damage to separators, thus causing short circuits between plates.
- battery overheating and consequent damage to internal parts of same. Beyond a certain limit this will also cause deformation of cell containers and damage to sealing compound.

UNDERCHARGE

This fault is less frequent than the above and its consequences are less conspicuous. However, a prolonged undercharge condition or inactivity condition without adequate charge will cause sulphation in active material, very difficult to be eliminated.

LACK OF WATER

If electrolyte level is left to go down below the top edge of plates, serious damage (often irreparable) will then ensue to active material and separators.

IMPERFECT SECURING

If battery is not perfectly secured to support bracket, vibrations and shocks received while the machine is running might cause damage

to separators and to plates, from which active material might fall apart. Furthermore an imperfect securing might cause cracks in cell containers, damage to covers and also leaks of acid from cell plugs.

ELECTROLYTE FREEZING

In winter freeze a discharged battery is subject to electrolyte freezing. Ice formation inside battery can disintegrate plates.

INSPECTION OF INNER PARTS

Never open and strip a battery without having previously tried to charge same and restore correct density. Nevertheless, when a short circuit is certainly detected, it will be necessary to carry out an internal inspection by skilled personnel in order to try to remove the fault and find out the cause of same.

This inspection should always be made with a suitable charged battery

SHORT CIRCUITS

Short circuits mainly happen by plate edges and they are generally due to the following reasons:

- « bridges » or branches of spongy lead caused by presence of active material in electrolyte. This type of short circuit, of course, is more likely to happen if plate separators are not properly centered or if they are damaged,
- Lead flashes or drops between plates.

INSPECTION OF POSITIVE PLATES

- check corrosion of grids. Should corrosion marks be detected on vertical ribs or on plate frames, plates must be regarded as useless.
- check that plates are not bent. Positive plates may be found bent, but should such bending exceed 5-6 mm. (.019-.023") reconditioning is unlikely to be possible.

- drop of active material. In this case the pits will be found empty, while grid will still be in good condition. Space underneath plates will be covered with a sort of mud.

INSPECTION OF NEGATIVE PLATES

- scratch paste with a fingernail, in order to check that same has not hardened. If the lead, which is the main component of the negative charge, is still in a spongy state, consistence will be soft and a shiny track will appear.

Hardening of negative paste must be considered as virtually unavoidable in batteries after long service on machine. Generally this fault reduces battery efficiency but does not jeopardize normal service.

- check if there is any fall of negative active material. This is a rather unusual fault and it mainly happens in consequence of long overheating or because of electrolyte density above normal.

INSPECTION OF SEPARATORS

Separators edges and corners must be unimpaired and viewing separators against light no perforation must be detected. If the battery had to withstand excessive vibrations or shocks, more or less deep abrasions could be found on separator corners.

INSPECTION OF CELL CONTAINERS

Inspection of cell containers must be carried out even before opening the single cells. Possible electrolyte leaks are detected by applying compressed air to plug holes and leaving then battery for a few hours (previously washed and dried outside) over a clean paper sheet. Spots on paper will denounce possible leaks from battery bottom. Any leak due to cracks in battery walls will be detected by acid trasudation. To detect possible cracks in partitions between cells, apply compressed air to each plug hole and check if there is any leak in adjacent cells.

GENERATOR

DESCRIPTION

The generator fitted on this machine is a MARELLI DN 62 N Type (see Fig. 114).

Features are the following: 300 W - 12 V - 2400 RPM - bipolar - dia. 101 mm. (4") - open construction type - separated regulator unit. Rotor supported at ends by two sealed-for-life ball bearings, which do not require any maintenance. Covers are secured to generator casing by means of two studs passing thru interpolar spaces. On outer side of generator cover (commutator side) there are the terminals D+/51 and DF (see A and B on Fig. 114). D+ terminal is connected to positive brush, while DF terminal is connected to one end of the inductor winding. D+ and DF generator terminals must be connected respectively to D+ and DF terminals of regulator unit.

OPERATION

When generator is connected to regulator unit and set into rotation, generated current gradually increases as R.P.M. increase. No current will be delivered until contacts of regulator unit are closed. After closing of regulator unit contacts, current originated from generator will flow to battery and utilizers and intensity of current will depend on charge condition of battery and absorption of inserted utilizers, accordingly to the setting of regulating section, which consists of tension regulator and current limiter.

It must be remembered that generator must always work connected to its own regulator unit. Therefore, when carrying out bed tests or engine tests it is not advisable to connect DF terminal directly to D+ terminal, because in such condition the generator will act as a simple generator shunt-excited and its tension will then increase following revs increase. High tension thus generated will cause a strong exciting current which might damage inductor winding.

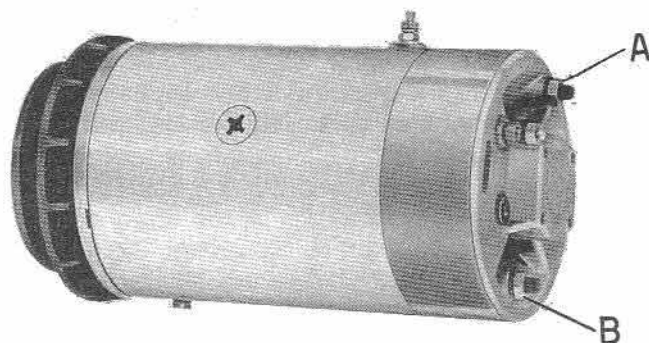

Fig. 114

REGULATOR UNIT

Regulator unit is a MARELLI IR 50 BA Type, located on upper frame beam (see Fig. 115). Being the generator driven by the engine with a rotation range subject to accentuate variations, the adoption of the generator is subordinate to the availability of a device able to keep the tension originated from the generator practically independent from the No. of revs of same. The regulator unit fitted on this machine con-

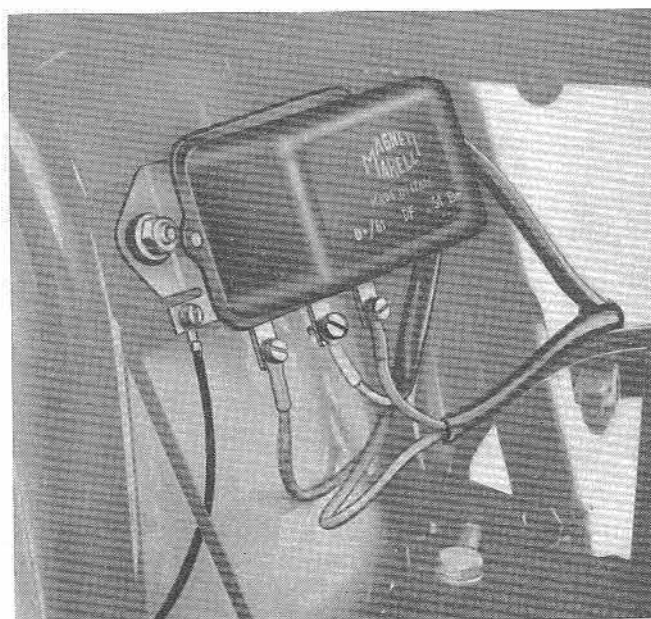

Fig. 115

sists of three separate devices, each one performing his own task. The three devices are the following: circuit breaker, tension regulator and current limiter. The task of the latter, as already said, is to avoid that the generator is required to deliver an amount of current exceeding the rated value.

The advantage obtained by the adoption of this type of regulator in place of the types with one or two cores only consists in the fact that the current limiter, working separately from tension regulator, enables the latter to deliver a constant current also when load varies. In other regulator units current limitation is obtained by battery intervention and this causes tension yieldings. Operating features of the three cores regulator unit are clearly shown on Fig. 116. Diagrams on Fig. 116/1 show the different operating stages.

In diagrams of Fig. 116/1, position A shows rest condition, when generator is running at low speed. Position B is when generator reaches connecting speed (connection with battery). Position C shows the beginning of regulation and position D shows operation of current limiter in case of overload on generator.

The current limiter enters into action when the maximum of a predetermined current is reached for instance when there is contemporary insertion of utilizers with a discharged battery. In the very moment the maximum current is exceeded, the regulator keeper is attracted by the field electromagnet which is rated for such maximum. Current limiter contacts (CL) open, thus causing connection of resistance (RRL) in circuit (CD) of generator excitation field.

When current regulation begins, generator tension lowers and therefore current regulator

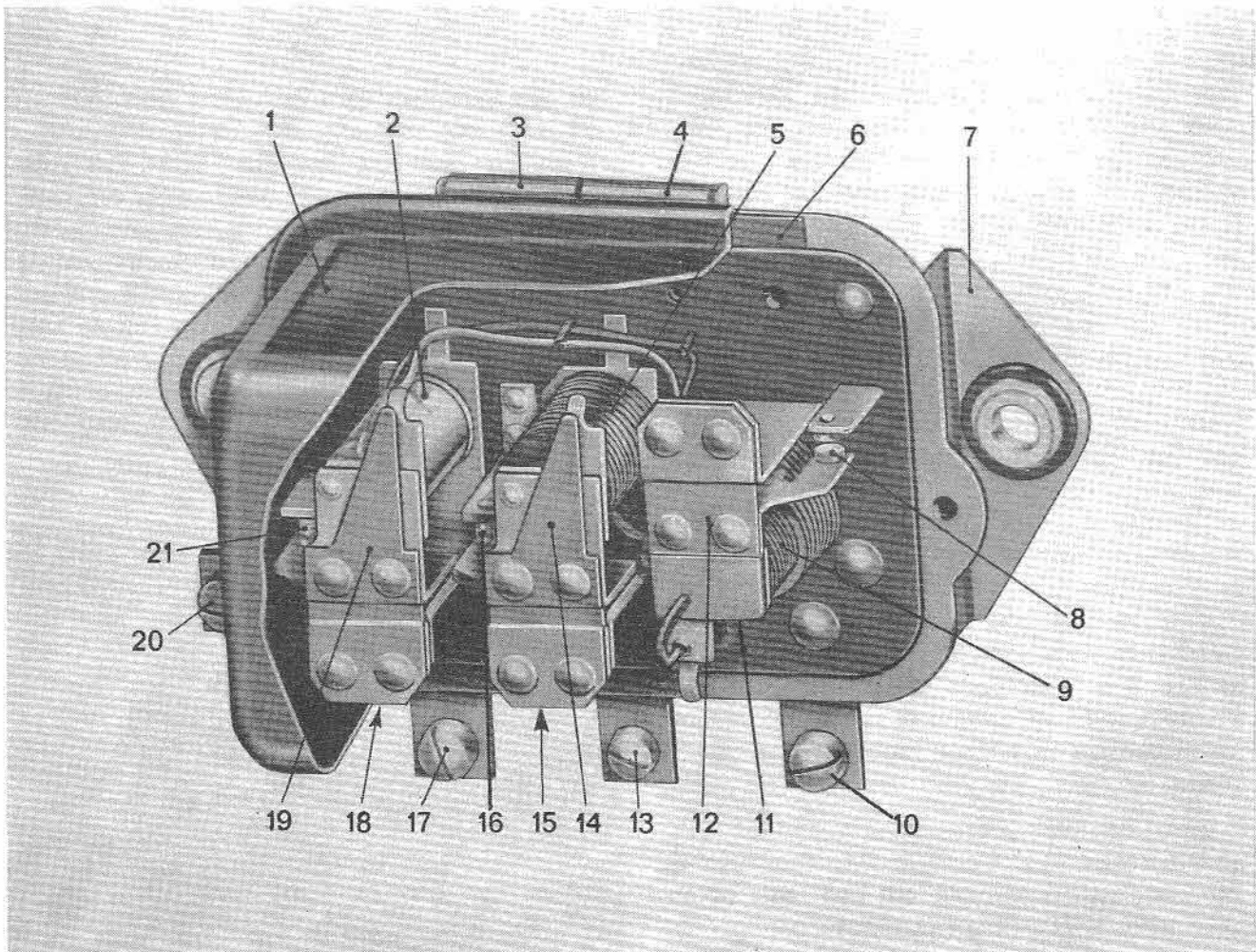

Fig. 116 - Cutaway view of three-core regulator unit.

- 1) Cover - 2) Regulator voltage coil - 3) Voltage resistance - 4) Regulator and limiter resistance - 5) Limiter current coil - 6) Cover gasket - 7) Regulator securing flange - 8) Circuit breaker contacts - 9) Circuit breaker current coil - 10) Battery positive pole terminal (30/B+) - 11) Circuit breaker - 12) Circuit breaker keeper - 13) Generator excitation terminal (DF/67) - 14) Limiter keeper - 15) Current limiter - 16) Limiter contacts - 17) Generator positive terminal (D+/51) - 18) Tension regulator - 19) Regulator keeper - 20) Negative terminal (D-/31) - 21) Regulator contacts.

ceases to work. If the current which caused the tension rise does not cease, current limiter will act as a current regulator, keeping the current delivered by the generator down to the rated value. The current limiter, therefore, protects the generator down to the rated value. The current limiter, therefore, protects the generator power and besides that it adjusts

tension (and consequently battery charge current, in order to allow a more regular charge of same. Regulation tension must not exceed battery overcharge tension, in order to avoid a too high charge current, and it must not be too quick reduction of charge tension and a prolongation of charge, which would prevent the battery from reaching a good charge condition.

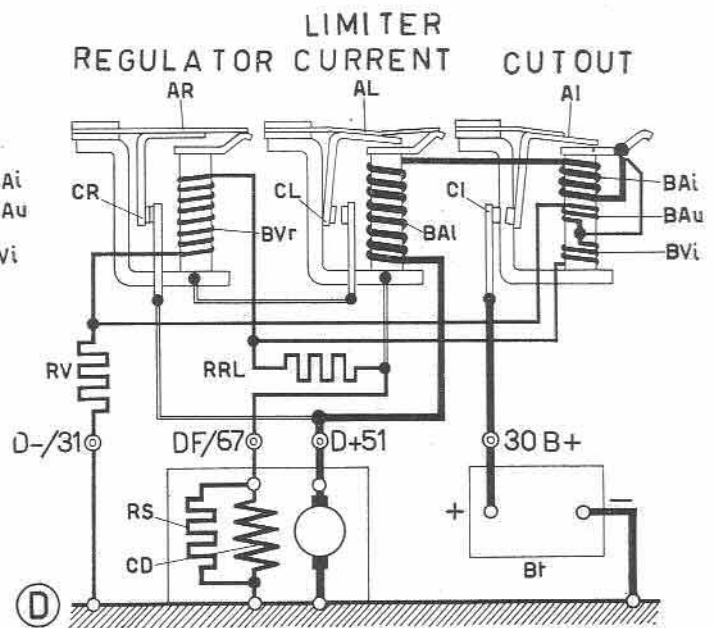
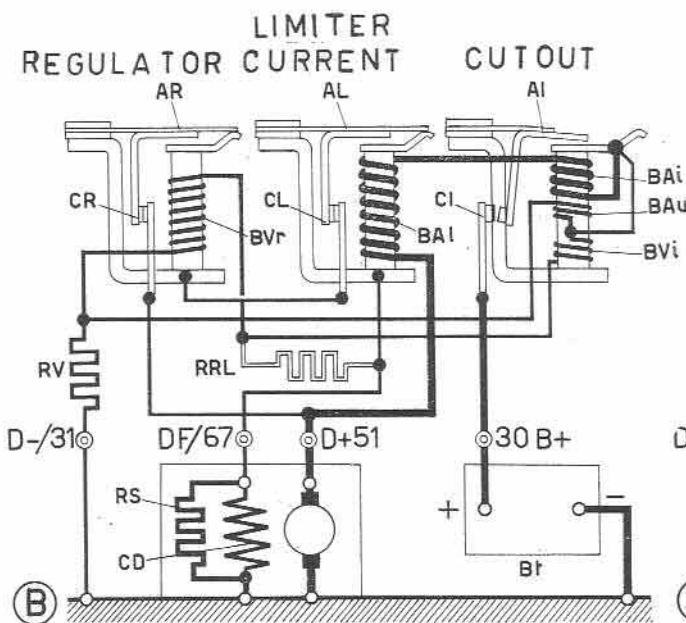
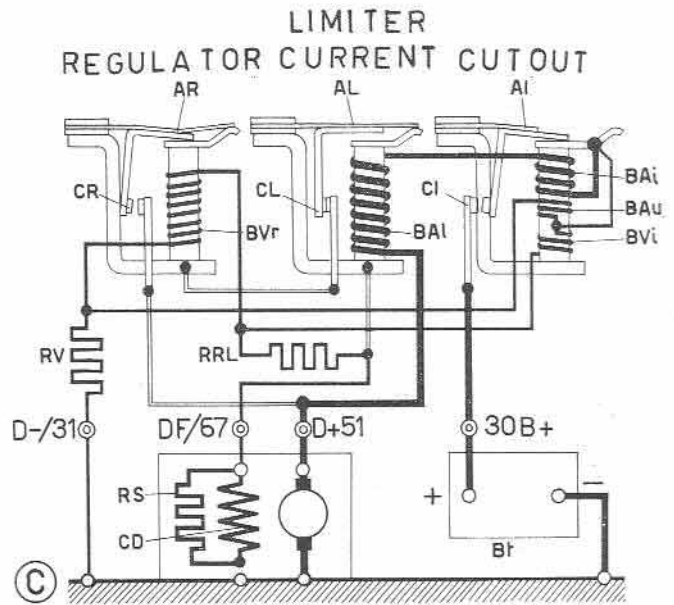
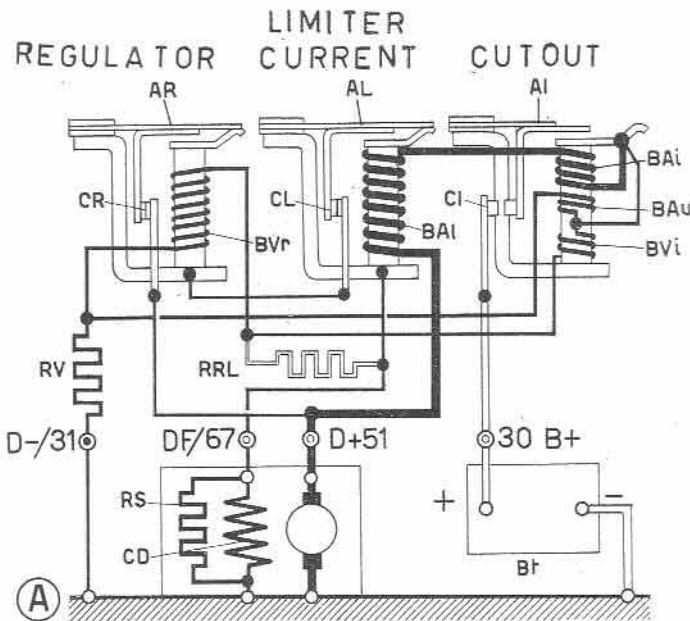

Fig. 116/1 - Operating stages of the three-core regulator unit. AI: circuit breaker keeper. AL: limiter keeper. AR: regulator keeper. BAI: circuit breaker current coil. BAI: limiter current coil. Bt: battery. BVi: circuit breaker voltage coil. BVR: regulator voltage coil. CD: generator field. CI: breaker con-

acts. CL: limiter contacts. CR: regulator contacts. D+51: generator positive terminal. D-/31: generator negative terminal. DF/67: generator excitation terminal. M: ground. RRL: regulator and limiter resistance. RS: damping resistance. RV: voltage resistance. 30/B+: battery positive terminal.

GENERATOR TESTING DATA

FEATURES

Type No.	Rated voltage	Current	Direction of rotation	Operating speed		Regulator unit	
	V			A	min. (*)	max.	Type No.
DN 62 N	12	25	CW	2400 RPM	10000 RPM	IR 50 BA	3

(*): at full power.

Bipolar type generator, casing dia. 101 mm. (4").
 Open type construction.
 Oscillating axle type fixation.
 Regulator unit separated from generator.

GENERATOR WITHOUT REGULATOR

Electrical tests (at room temperature of 20° C (68° F))

Overall resistance of field winding (CD) . . .	4.6 ± 0.2 Ω
Rating of damping resistance (RS)	—
Connection speed with no load (tension 13 V)	1500 RPM
Load rating (tension 13 V, current 23 A) . . .	2300 RPM

TENSION AND INSULATION TESTS

Check dielectric rigidity by feeding for 3 sec.s with 500 V, 50 Hz, A.C. Check insulation resistance by feeding with 500 V, D.C. - Resistance value must be over 2 M Ω.

NB: When carrying out above tests, temporarily disconnect possible groundings.

MECHANICAL TESTS

Brush springs load	1000-1100 gms.	(2.2-2.4 lbs.)
I/D of pole shoes after fitment	65.7-66.0 mm.	(2.5865-2.5984")
O/D of rotor	64.9-65.0 mm.	(2.551 - 2.559")

GENERATOR WITH REGULATOR

Regulator	Connection voltage	Recovery current	No-load adjusting voltage	Loaded adjusting voltage	Current limiter on	Load at rated voltage
	V	A	V	V	A	W
IR 50 BA	11.5 ÷ 13	2 ÷ 8	13.8 ÷ 14.4	—	28,5 - 30,5	300

ADJUSTMENT OF GENERATOR BELT TENSION

Generator belt might slacken with use and slipping might then ensue. It is necessary therefore to check correct tension (see Fig. 116/2). Normal slack is 1 cm. per 10 kgs. pressure (.39"/21 lbs). To obtain correct belt tension proceed as follows:

- unscrew bolts (C) which secure the outer half-pulley to the hub.
- remove outer half-pulley.
- remove one or more adjusting collars, thus reducing width of pulley race.

If more than one collar is removed, fit these back at the front and rear end of the pulley. Refit outer half-pulley tightening up the 3 securing bolts (C).

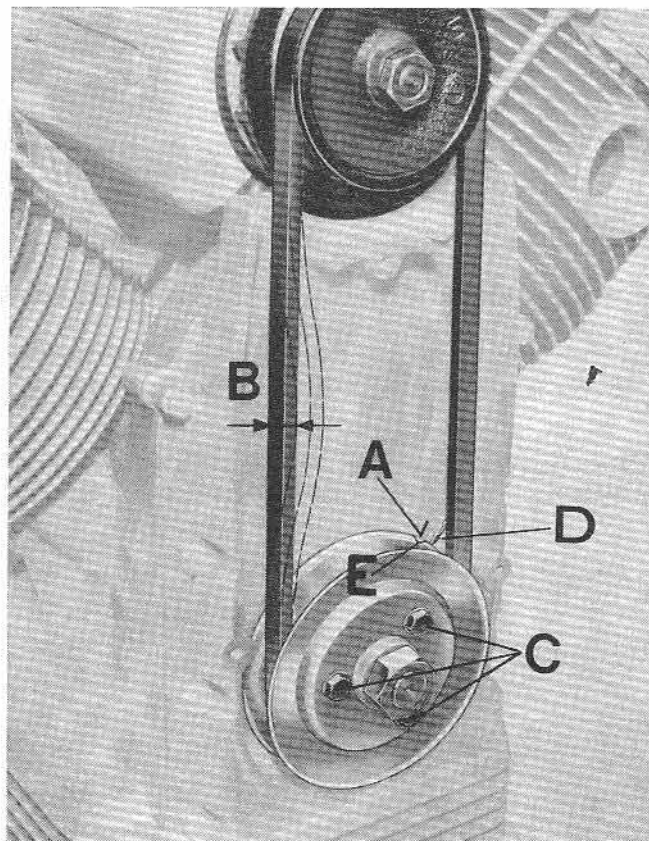

Fig. 116/2

GENERATOR FAULTS

FAULTS	POSSIBLE CAUSES	REMEDIES
<p>Generator does not charge battery.</p>	Blown fuse on generator or battery positive terminal.	Check and if necessary replace fuse. Fuse contact could also be defective or fuse could be not properly housed in its seat.
	Break in charge circuit.	Locate break and repair it. Breaks are generally due to loose or oxidated terminals.
	Direction of rotation contrary to normal.	Reset correct direction of rotation.
	Slack generator belt.	Adjust belt to correct tension.
	Faulty battery.	Check battery.
	Defective contact of brushes with commutator; dirty commutator; brushes not freely sliding in holders or worn out.	Clean commutator, clean brush holders or replace brushes.
	Grounded brush holder.	Reset brush holder insulation and if necessary replace it.
	Grounded or broken rotor winding.	Replace rotor.

FAULTS	POSSIBLE CAUSES	REMEDIES
	Short-circuited rotor.	Clean carefully between rotor blades. Make sure that there are no welding drops on front face and especially on back side of commutator ring. If so, remove them. Failing to attain a good result, replace rotor.
	Rotor unwelded from commutator.	If rotor does not show any other fault, renew welding.
	Broken field windings, or short-circuited or grounded.	Replace field coils, unless grounding is spotted and eliminated.
	Generator lacks residual magnetism.	Re-excite generator by connecting for an instant positive and negative field winding terminals to positive and negative battery terminals.
	Circuit breaker out of setting.	Set circuit breaker accordingly to testing data.
	Oxidation of circuit breaker contacts.	Clean circuit breaker contacts.

FAULTS	POSSIBLE CAUSES	REMEDIES
<p>Generator is slow to start battery charge.</p>	<p>Jammed contact breaker keeper; deformed movable contact spring; broken or short-circuited contact breaker windings.</p>	<p>Replace regulator unit and send it for repair to an Authorized Dealer.</p>
	<p>Tension regulator out of setting.</p>	<p>Reset tension regulator accordingly to testing data.</p>
	<p>Oxidation of tension regulator contacts.</p>	<p>Clean tension regulator contacts.</p>
	<p>Broken tension regulator windings or broken current circuit and excitation circuit.</p>	<p>Replace regulator unit and send it for repair to an Authorized Dealer.</p>
	<p>Faulty regulator unit.</p>	<p>Replace regulator unit.</p>
	<p>Partially short-circuited rotor.</p>	<p>Replace rotor.</p>
	<p>Partially short-circuited field windings.</p>	<p>Replace field coils.</p>
<p>Grounded field windings.</p>	<p>Unless grounding can be eliminated, replace windings.</p>	

FAULTS	POSSIBLE CAUSES	REMEDIES
<p>Battery gets only partially charged.</p>	<p>Circuit breaker out of setting.</p> <p>Low setting of regulator unit.</p> <p>Oxidation of regulator unit contacts.</p> <p>Loose or defective connections inside regulator unit.</p> <p>Faulty battery.</p>	<p>Reset circuit breaker. If good result is not attained, replace same.</p> <p>Set regulator accordingly to testing data.</p> <p>Clean regulator unit contacts.</p> <p>Check and make connections efficient.</p> <p>Check battery.</p>
<p>Generator overcharges battery.</p>	<p>Faulty generator grounding.</p> <p>Excitation circuit and generator positive in direct short circuit.</p> <p>High setting of regulator unit.</p> <p>Faulty regulator windings.</p>	<p>Re-establish connection.</p> <p>Overhaul system and eliminate fault.</p> <p>Set regulator accordingly to testing data.</p> <p>Replace regulator and send it for repair to an Authorized Dealer.</p>

FAULTS	POSSIBLE CAUSES	REMEDIES
Battery discharges over generator.	Faulty regulator unit.	Replace regulator unit.
Generator tension is not constant and exceeds prescribed value.	Faulty regulator unit.	Replace regulator unit.
Tension oscillates: it is not constant.	Oxidation of regulator unit contacts.	Clean regulator unit contacts.
	Regulator unit with altered air gaps, loose screws, etc.	Send regulator unit to an Authorized Dealer for repair.
Overheating of generator.	Short-circuited rotor.	Replace rotor.
	Regulator unit damaged or out of setting.	Reset regulator unit or replace it.
Brushes wear out too quickly.	Offset commutator.	Turn commutator and remove excess of mica.
	Excessive pressure of brush holder springs.	Take spring pressure down to correct load.

FAULTS	POSSIBLE CAUSES	REMEDIES
Excessive sparking at commutator.	<p>Brushes of poor quality.</p> <p>Break in rotor winding.</p> <p>Rotor unwelded from commutator.</p> <p>Offset commutator.</p> <p>Loose brush holder springs.</p> <p>Worn out brushes.</p> <p>Mica protruding from commutator bars.</p>	<p>Replace brushes, fitting original parts.</p> <p>Replace rotor.</p> <p>If rotor does not show any other fault, renew weldings.</p> <p>Turn commutator and remove excess mica.</p> <p>Replace springs or restore correct spring load.</p> <p>Replace brushes.</p> <p>Remove excess mica.</p>
Noisy generator operation.	<p>Rotor rubs against pole shoes.</p>	<p>Check if pole shoes are correctly secured to casing. Replace bearings.</p>

STARTER MOTOR

The starter motor fitted on the «V7» is a MARELLI MT 40 Type. Main features are the following:

- Tension 12 V
- Rated output 0.7 HP
- Direction of rotation CW
- Poles 4
- Series excitation type winding.

DESCRIPTION (see Fig. 117)

This starter motor is provided with an electromagnetic control (6) which is secured by means of bolts to a suitable housing in support casting (26). Inside such housing are located the portion of keeper (2) which protrudes from the electromagnet, the return spring (1) and the lever (27) which controls the advancement of the pinion. Solenoid switch is provided with big terminals to be respectively connected to the battery and to one end of field winding. Solenoid switch is also provided with plug (9)

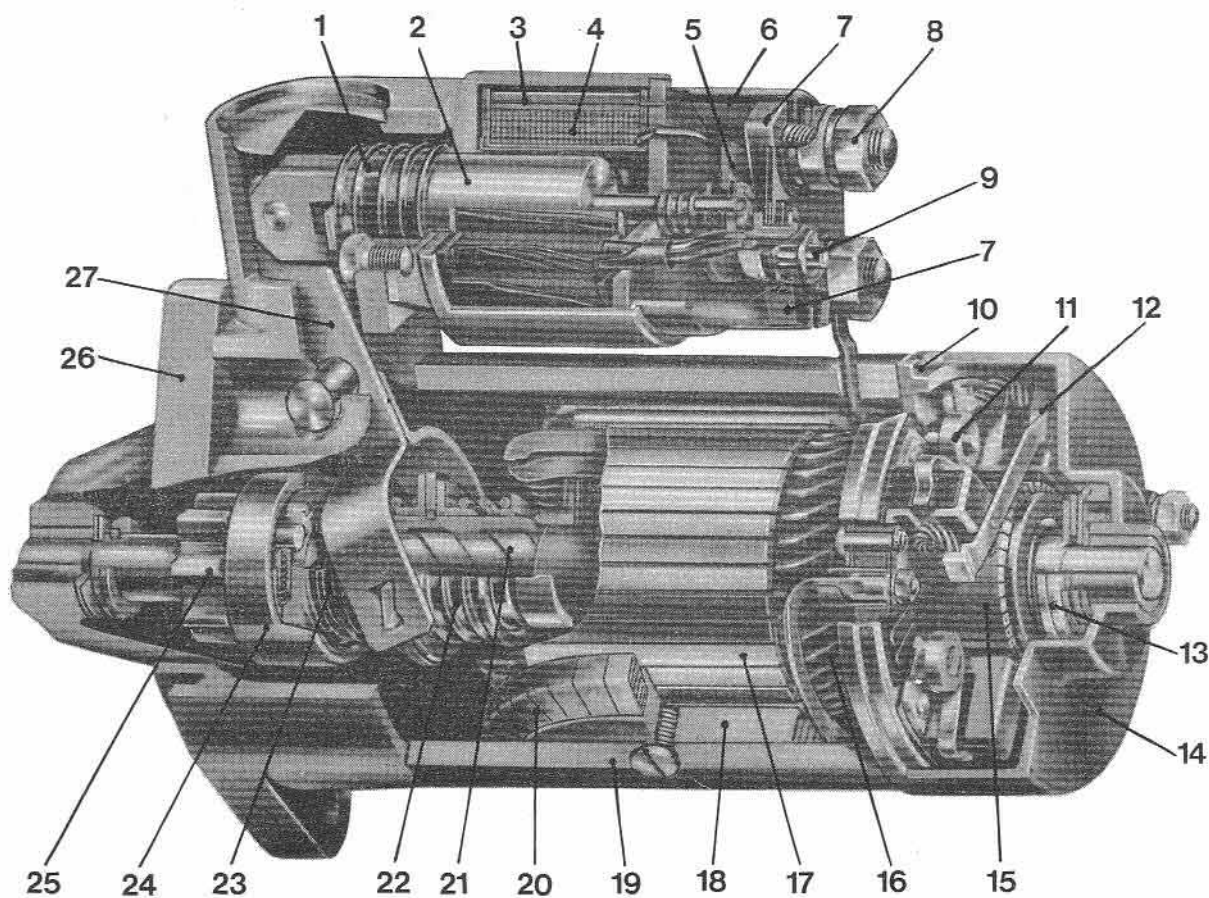

Fig. 117 - Cutaway view of starter motor.

1. Keeper return spring - 2. Solenoid keeper - 3. Retaining coil - 4. Coupling coil - 5. Movable contact - 6. Solenoid switch - 7. Switch contacts - 8. Terminal for connection to battery - 9. Terminal for connection to ignition key - 10. Brush holder ring - 11. Brush spring - 12. Brush - 13. Disc

brake - 14. End cover, commutator side - 15. Commutator - 16. Rotor winding - 17. Rotor - 18. Pole shoe - 19. Casing - 20. Field winding - 21. Fast pitch thread - 22. Release spring - 23. Coupling spring - 24. Roller freewheel - 25. Pinion - 26. End cover, pinion side - 27. Coupling control lever.

for connection of electromagnet feeding cable. Winding of electromagnet consists of two coils in parallel, namely coupling coil (4), wound up with copper wire dia. about 1 mm. (.039"), and retaining coil (3), located around the above and wound up with copper wire of half the above dia. The double coil is particularly useful owing to the fact that the solenoid, because of the wide air gap existing between the keeper and the core when the lever is at rest, must initially exercise a remarkable traction force on the keeper. Such force is obtained by concomitant action of the two coils. However, when keeper reaches the position in which the movable contact (5) closes on the stationary contacts (7), Owing to the particular arrangement of the circuits the coupling coil is cut off, so that keeper is retained solely and sufficiently by attractive force generated by retaining coil, being now the air gap virtually nonexistent. The two coil arrangement also enables to obtain a reduction of battery current consumption and it avoids voltage drops at starting moment, when load on battery is already high because of the starter motor operation.

Cam windows have been abolished in this motor, and consequently also brushes protective band, so that casing length could be reduced. Brushes (12) still in quantity of 4, are provided with brush holders inside light alloy die-cast ring (10), which is positioned by means of suitable ledge at casing end (19). Brush holder ring is secured to casing by means of two studs, together with cover (14) which incorporates rotor support bushings and protects brushes and rotor from dust, water, etc.

OPERATION (see Fig. 118)

In rest condition, shown in position A, pinion is free and there is no current in the starter motor windings.

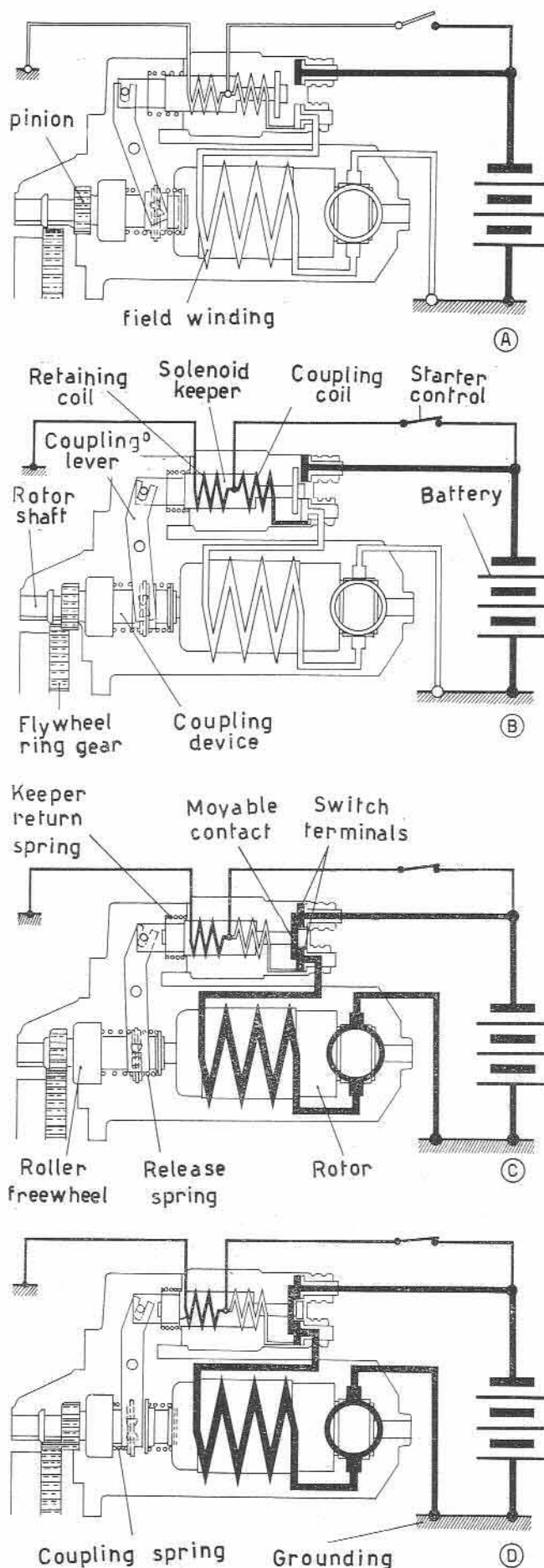

Fig. 118 - Operation of thrust-screw combined coupling device.

In position B, following the action of ignition key on instrument panel, the current flows from the battery thru coupling coil and solenoid retaining coil. The pinion, which in this type of motors can slide together with all coupling device along a variable pitch thread on rotor shaft, is thrust towards outside by the coupling lever in such a measure as to engage the flywheel ring gear. Coupling lever is controlled by solenoid keeper.

In position C, owing to the shifting of the solenoid keeper, the movable contact attached to same closes the switch contacts and the motor field windings are then run thru by main current. Motor rotor begins to rotate and the pinion, which so far couldn't rotate owing to the mechanical resistance of the flywheel ring gear, screws itself along rotor shaft thread, thus compressing release spring, and thrusts itself until full engagement of its teeth and ring gear teeth is attained. As soon as the pinion gets in touch with suitable limit stop on rotor shaft, positive coupling of pinion and rotor is obtained and flywheel is then driven by starter motor.

If after the engine is started the flywheel speed exceeds the pinion speed, this is disengaged from rotor shaft by means of the roller freewheel device, and remains engaged to the flywheel until ignition key is released by rider and coupling lever is shifted back to rest position by keeper return spring. Without the freewheel device both pinion and rotor would be driven to whirling speed, owing to the high flywheel-pinion ratio, thus risking rotor to get shattered by centrifugal force.

Also in this motor a disc brake device allows a rapid stoppage of rotor. This will avoid damage to pinion and ring gear teeth, as it would happen if, failing a first engine starting, the rider should try the next starting before the rotor is still. During this phase (position C) the keeper is retained by the action of retaining coil only. The coupling coil, short-circuited, is cut off. Position D shows the possibility that the pinion, during its advancement, does not engage the ring gear because the pinion teeth, even if provided with bevel, get frontally stuck against ring gear teeth, thus preventing coupling

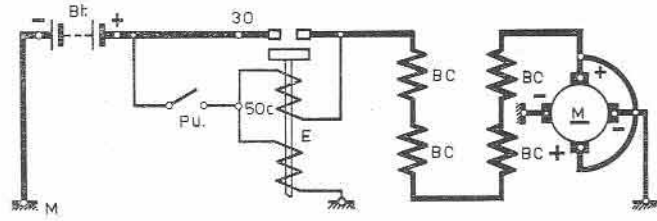

Fig. 118/1 - Wiring diagram.

BC: Field coil.
Bt : Battery.
E : Electromagnet.
Pu : Ignition key.
M : Ground.

from being attained. In this case the switch contacts can close all the same, being the coupling lever elastically connected to the pinion thru the coupling spring. As soon as the rotor will begin to rotate, the pinion, pushed by coupling spring, will at once engage flywheel ring gear.

Operating features of this coupling device will be more easily understood by looking at Fig. 119, which shows a cutaway view of same. As to wiring diagram, refer to Fig. 118/1.

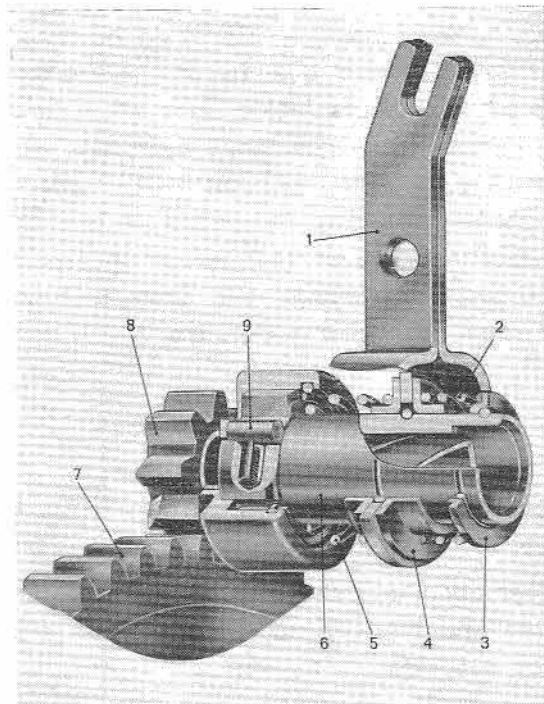

Fig. 119 - Cutaway view of the thrust-screw combined coupling device.

1. Control lever - 2. Release spring - 3. Release spring housing ring - 4. Sleeve - 5. Coupling spring - 6. Coupling hub - 7. Flywheel ring gear - 8. Pinion gear - 9. Roller freewheel.

STARTER MOTOR TESTING DATA

FEATURES

Type No.	Rated voltage	Rated output	Direction of rotation	Pinion gear		Solenoid switch
	V	HP		No. of teeth	Module	Type No.
MT 40 H	12	0.7	CW	8	2.5 D.P.	IE 13 DA

- 4 pole type, casing dia. 76 mm. (3").
- Pinion gear coupling device of thrust-screw
- type, operated by electrical control.
- Flange mounted.

ELECTRICAL TESTS

Operating condition	Voltage V	Current A	RPM	Torque	
				Kg.cm.	ft.lb.
— No-load	11.6	≅ 25	11000-11500	—	—
— Full load	10	≅ 100	3200-3500	0.15	1.08
— Short circuit	7	≅ 300	—	0.75	5.42

VOLTAGE AND INSULATION TEST

Check dielectric rigidity by feeding for 3 sec.s with 500 V, 50 Hz, A.C. Check insulation resistance feeding with 100 V, D.C. - Resistance

value must be 2 MΩ.
NB: When carrying out above tests, temporarily disconnect possible ground connections.

MECHANICAL TESTS AND DIMENSION

- Torque moment for rotation of pinion gear (shifting in freewheel motion) : 0,4-0,5 Kg/cm² (2.89-3.61 ft. lb.)
- Rotor braking moment (moment in which the rotor, with coupling lever at rest, is stopped by disc brake device) : 2.5-4.0 Kg/cm² (18-28.9 ft. lb.)
- Diameter of pole shoes : 52.6-53.0 mm. (2.0708 - 2.0865")
- O/D of rotor : 51.9-52.0 mm. (2.0468 - 2.0472")
- I/D of bushing, coupling side : $10 \begin{matrix} + \\ - \end{matrix} \begin{matrix} 0.015 \\ 0 \end{matrix}$ mm. (.3937 $\begin{matrix} + \\ - \end{matrix} \begin{matrix} .0005'' \\ 0 \end{matrix}$)
- I/D of bushing, commutator side : $10 \begin{matrix} + \\ - \end{matrix} \begin{matrix} 0.015 \\ 0 \end{matrix}$ mm. (.3937 $\begin{matrix} + \\ - \end{matrix} \begin{matrix} .0005'' \\ 0 \end{matrix}$)

SOLENOID SWITCH TEST

Type No.	Absorption	Coupling voltage	Release voltage	Load force		Total core travel
				Kg.	lbs.	
DE 13 DA	27-53	4	1-6 0.4-2	15	33.06	9.5 mm. (.374")

TEETH CONTRAST TEST

Making one pinion tooth face to contact one ring gear tooth face, the coupling lever must still have 1 mm. (.0394") of travel left, that is to say that when switch contacts are completely close, coupling spring must still be compressed for one further mm. before its coils touch each

other. The test must be carried out as follows: Insert a steel plate, 1 mm. thick (.0394"), between pinion and ring gear, then push coupling lever and check by means of a lamp that the switch contacts are closed.

STARTER MOTOR FAULTS

FAULTS	POSSIBLE CAUSES	REMEDIES
<p>Motor does not rotate and there is no current absorption.</p>	<p>Break of circuit between battery and starter motor.</p>	<p>Locate break and repair it. Check battery terminal blocks and starter cable terminals. Tighten securing nuts perfectly.</p>
	<p>Break of circuit between starter motor and ignition key.</p>	<p>Locate break and repair it. Check condition of key switch contacts and if necessary clean them carefully, smoothing surface by means of suitable file.</p>
	<p>Oxidation of battery terminal blocks or loose terminals.</p>	<p>Clean battery terminal block and tighten terminals.</p>
	<p>Ignition key switch does not close circuit.</p>	<p>Clean contacts of ignition key switch or replace complete switch.</p>
	<p>Solenoid switch oxidated contacts or with grounded or broken winding.</p>	<p>Clean movable and stationary contacts of solenoid switch or replace winding.</p>
	<p>Brushes are too worn out and fail to contact the commutator.</p>	<p>Replace brushes, making sure to fit original parts.</p>

FAULTS	POSSIBLE CAUSES	REMEDIES
<p>Starter motor is absorbing current but does not rotate or rotates very slowly.</p>	<p>Rotor rubbing against polar shoes or jammed between same.</p> <p>Rotor shaft is seized.</p> <p>Rotor shaft is too tightly housed in bushings.</p> <p>Short-circuited or grounded field winding.</p> <p>Discharged battery, or deteriorated in one or more cells.</p>	<p>If bushings are too worn out, replace them. Check bearings alignment. Check rotor shaft. Check that polar shoes are properly housed and secured to casing.</p> <p>Replace bushings and recondition rotor shaft.</p> <p>Clean rotor shaft and bushings and lubricate. If not enough, replace bushings.</p> <p>Strip field coils and replace them, or, if possible, repair them.</p> <p>Charge or repair battery.</p>
<p>Starter motor rotates but fails to start engine.</p>	<p>Break or grounding in rotor.</p> <p>Short-circuited rotor.</p>	<p>Replace rotor.</p> <p>Remove copper and carbon dust from commutator and brush holders. Check rotor and if necessary replace it.</p>

FAULTS	POSSIBLE CAUSES	REMEDIES
<p>Starter motor sets itself regularly to work but makes excessive or unusual noise.</p> <p>Starter motor does not deliver full output.</p>	<p>Worn out ring gear teeth: pinion does not engage ring gear.</p>	<p>Replace flywheel ring gear.</p>
	<p>Incorrect assembling: ring gear is only partially engaged by pinion.</p>	<p>Check coaxiality and distance between pinion and ring gear.</p>
	<p>Impurities in coupling device assembly, which does not slide properly on rotor shaft.</p>	<p>Clean and lubricate. If necessary clean complete coupling device assembly.</p>
	<p>Pinion engages ring gear but no starting takes place.</p>	<p>Faulty pinion freewheel, to be replaced. Faulty clutch, to be overhauled or replaced. Partial operation of solenoid switch, which must then be repaired or replaced.</p>
	<p>Faulty mechanical parts.</p>	<p>Check bushings and if necessary replace them.</p>
	<p>Presence of foreign matters.</p>	<p>Eliminate foreign matters.</p>
<p>Brushes not making a good contact on commutator.</p>	<p>Replace brushes or make them match with commutator by setting the motor to work for a certain time without any load. Check load of brush springs and if any yielding is noticed replace them.</p>	

FAULTS	POSSIBLE CAUSES	REMEDIES
Brushes wear out too quickly.	<p>Brushes don't slide freely in brush holder.</p> <p>Ovalized commutator.</p> <p>Mica protruding from copper commutator blades.</p> <p>Loose brush holders.</p> <p>Brushes exercise an excessive pressure on commutator.</p> <p>Unsuitable brushes.</p>	<p>Clean brush holder guides or replace brush holder, if necessary.</p> <p>Turn commutator and remove excess of mica.</p> <p>Clean commutator and remove excess of mica.</p> <p>Tighten brush holder securing screws and rivets.</p> <p>Check springs load to be of the required value.</p> <p>Replace brushes, fitting original parts.</p>
Sparking at commutator.	<p>General overload.</p> <p>Loose brush springs.</p> <p>Mica protruding from copper.</p> <p>Loose brush holder.</p>	<p>Overhaul starter motor.</p> <p>Replace springs.</p> <p>Remove excess of mica and clean commutator.</p> <p>Tighten brush holder securing screws and rivets.</p>

IGNITION SYSTEM

The ignition system comprises:

- ignition coil, MARELLI BE 200D type
- distributor, MARELLI S123A type
- low tension and high tension cables
- spark plugs, MARELLI CW 225 CVT or BOSCH W 225 T 2 type
- energy source, consisting of generator - Battery assembly.

GENERAL INFORMATION

The energy required for generating the sparks is supplied by the battery, with which, as already said, the machine is provided. Battery, however, supplies low tension current, while high tension will be necessary for the ignition.

Such transformation is provided by the « ignition coil » whose specific purpose is to convert low voltage current into high voltage current.

In multicylinder engines it is also indispensable to distribute the high voltage current to the spark plugs so that sparks are produced at the most suitable moment and accordingly to firing order. Such duty is performed by the « ignition distributor ».

Distributor duties are of rather a complex nature. Actually this device must break low voltage current and distribute high voltage current to each plug accordingly to the advance required by the engine.

Distributor comprises: contact breaker unit, condenser, distributor rotor, distributor cap and a spark advance device, which is generally automatic.

COIL

Description

Ignition coil, MARELLI BE 200 D, consists basically of two windings: the primary winding (small number of turns wound up with thick

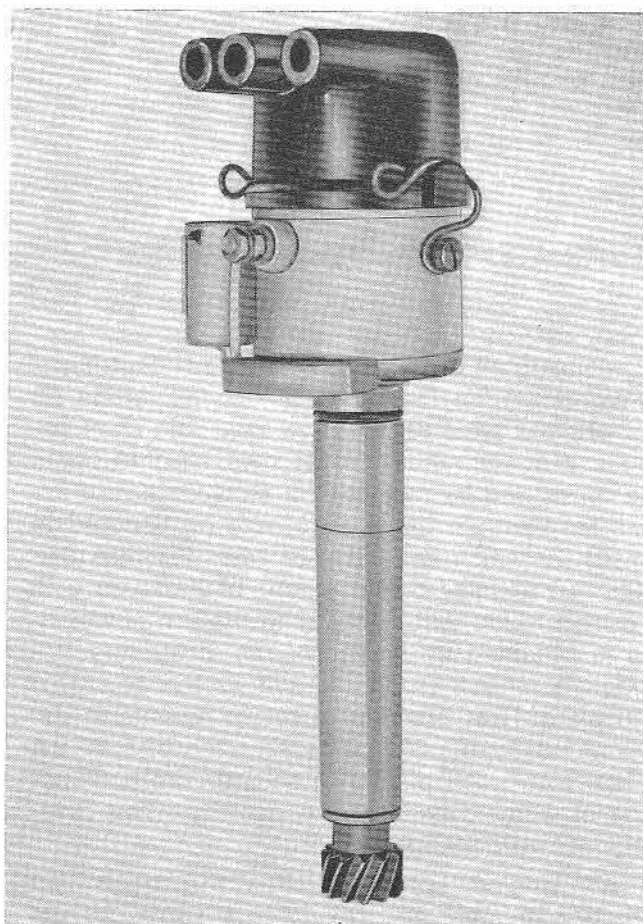

Fig. 120

gauge wire) and the secondary winding (high number of turns wound up with fine gauge wire).

DISTRIBUTOR (see Fig. 120)

Description

Ignition distributor is a MARELLI S123A type. This device comprises the automatic advance assembly, the contact breaker unit on low voltage circuit, the high voltage distributor cap and condenser.

Features

- Automatic advance: 14°
- Direction of rotation: CCW
- Automatic advance operating range: see diagram on Fig. 122.
- Contact breaker gap 0.42 - 0.48 mm. (.016 - .018").
- Contacts pressure: 475 ± 50 g.

AUTOMATIC SPARK ADVANCE DEVICE

(see Fig. 121)

Consisting of two suitably shaped centrifugal weights (1) having fulcrum on the studs (2) inserted in plate (3) which is solid with shaft (4). At a predetermined No. of revs weights begin to move and by means of a suitable slot in same they entrain the pins (5) and (6) secured to plate (7) which is solid with cam (8), thus causing an angular displacement of the cam with respect to the distributor shaft. Return of weights is obtained by means of return springs (10) hooked to the studs (2) and to the pins (11) on plate. Rest position of return springs is determined by pin (6) contacting the end of the plate slot. Lock plate (12) secures the positioning of weights and cam, especially when stripping down distributor rotor.

Every engine speed requires the equivalent ignition moment according to a curve (advance curve) which is then determined in relation

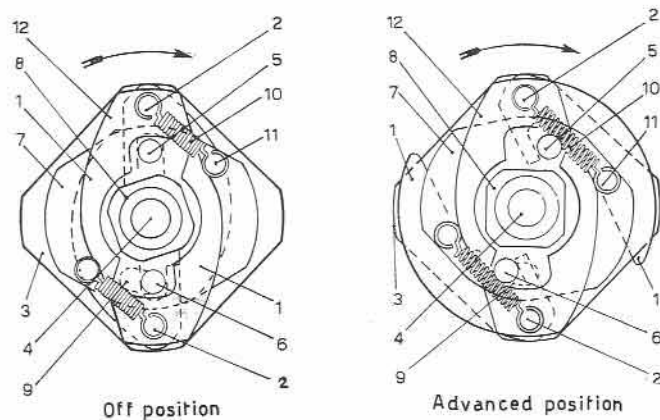
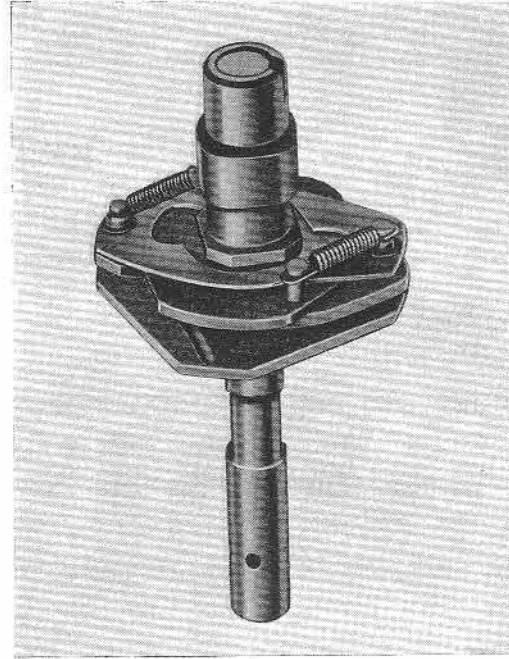

Fig. 121 - Operation of the automatic spark advance device.
1. Weight - 2. Stud - 3. Plate, solid with shaft - 4. Shaft - 5. Cam control pin - 6. Cam control pin - 7. Plate, solid with cam - 8. Cam - 9. Plate slot - 10. Return spring - 11. Spring stud - 12. Lock plate.

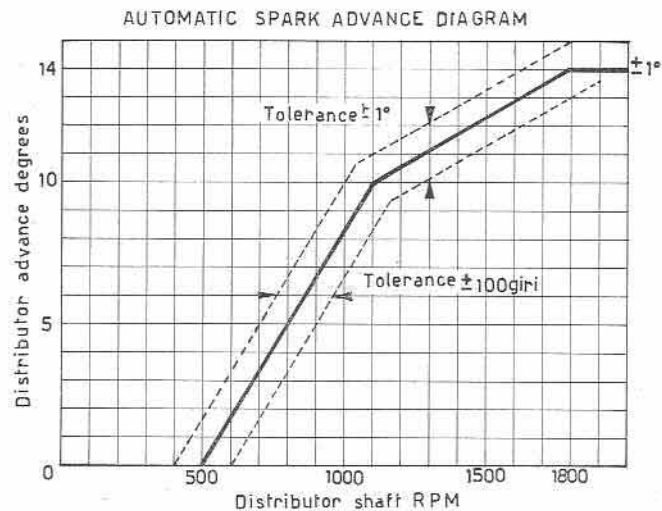

Fig. 122

to engine speed. Automation spark advance is then represented by a diagram (see Fig. 122) which shows the degrees of advance of the cam with respect to the speed of the distributor shaft.

CONTACT BREAKER (see Fig. 123)

The duty of the contact breaker is to break at intervals the low voltage current which flows in the primary winding of the ignition coil. Contact breaker consists of one plate (1), which is screwed to distributor body and which comprises the following parts:

- Fixed contact point holder (2) which can rotate for some degrees around pin (5) solid with plate and it is secured to plate by means of screw (3) in the most suitable position for obtaining a correct breaker gap.
- breaker arm (4) provided with movable contact point, pivoted on pin (5) and comprising flat spring (6) which secures contacts pressure and adherence of felt pad (7) to the two-nosed cam (8). Number of cam noses is always the same as the number of cylinders.

When contacts are closed, the low voltage current of the battery flows thru ignition coil primary winding and arrives to terminal (9). From here the current runs thru flat spring (6) and goes to ground thru contact point holder (2) and distributor body.

CONDENSOR

The condenser, which is inserted in parallel with contact breaker points, has the duty to make sharper the current break and in the meantime to damp the strong sparking originated at points by the break of primary winding. The condenser consists of two tin foil stripes, insulated by interpolation of paper stripes. The lot is then rolled up, dipped into special insulating oil and sealed in a casing. One of the tin foil stripes is internally connected to the metallic casing, while the other stripe is connected to an insulated terminal.

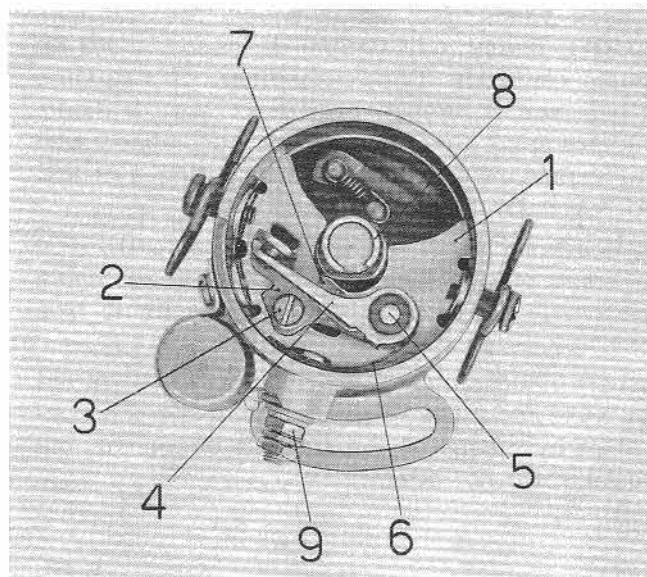

Fig. 123

1. Plate - 2. Fixed contact point holder - 3. Point holder securing screw - 4. Breaker arm - 5. Breaker arm pin - 6. Flat spring - 7. Felt pad - 8. Cam - 9. Terminal for connection to coil.

DISTRIBUTOR CAP AND ROTOR

Distributor cap and rotor can be described together because they form the high voltage current distribution system. Distributor cap and rotor are both in molded bakelite and include some metal parts which form separate circuits. One of these circuits, and exactly the central circuit, transfers the high voltage current received from the coil to the carbon brush which, owing to the pressure of a spring, is constantly in contact with the inner end of the rotor metal brush.

Rotor is positioned at top of cam spindle, thus rotating at the same speed of the distributor shaft. When rotor is in rotation, the outer end of the metal brush (contact piece) skims one after the other the metal sectors in distributor cap, thus transmitting the high voltage current pulses coming from ignition coil. After that, the current flows thru the two peripheral circuits of cap until reaching outlets in which are inserted the cables required to convey the current to the spark plugs. Ignition spark will take place between plug points. The number of the cylinder to which each cable must be connected is marked on the distributor cap.

SPARK PLUGS

Spark plugs fitted on this machine are MARELLI CW 225 LVT type or BOSCH W 225 T 2 type.

Check points gap, which should be 0.6 mm. (0.23"). If any adjustment is needed, act on outer electrode. Check condition of insulating piece and if breaks or cracks are detected, replace plug. Spark plugs can be cleaned with pure gasoline and a wire brush, using a needle to reach for the inner parts.

It is advisable not to change to a different type of spark plugs. Many engine irregularities could be avoided by constant use of the suitable type of spark plugs.

When fitting plugs, make sure they are started by hand for a few turns and complete the operation by means of the suitable wrench in the tool kit. Do not overtighten.

IGNITION TIMING

- Make sure that L/H cylinder (No. 2) is at T.D.C., on its compression stroke, i.e. with both valves closed. The arrow (see D on Fig. 124) on timing cover must be right opposite the slot (E) on generator belt pulley.
- Check that distributor contact gap (see A on Fig. 125) is 0.42-0.48 mm. (.016-.018). If not so, adjust by means of adjusting screw (B).
- Position the contact piece of rotor to skim the metal sector pertaining to cylinder No. 2 cable (this can be done by provisionally positioning the distributor cap and checking that contact piece of rotor is directed towards mark No. 2).
- Insert distributor in crankcase, making sure that driving pinion engages gear on camshaft and that distributor adjusting sector matches with threaded hole in crankcase, thus allowing fitment of adjusting bolt and washer.
- Rotate the generator belt pulley so to bring the slot (see E on Fig. 124) opposite to the mark (A) traced on timing cover. This mark is located in a 10° advanced position to the T.D.C. arrow indicator also embossed on the timing cover.

The distributor points should start to open in this position and to ensure that they do so, use a timing light which will light up at the exact time the points start to open.

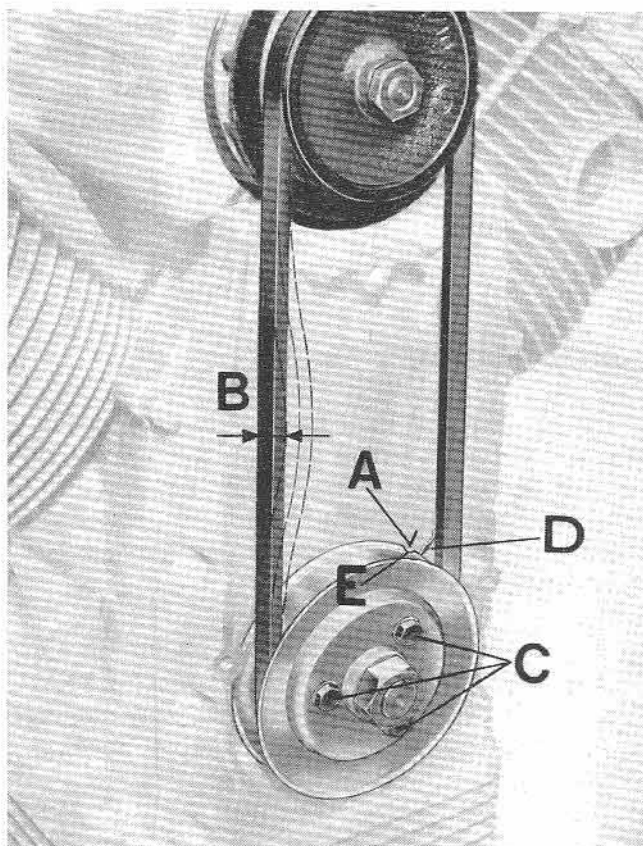

Fig. 124

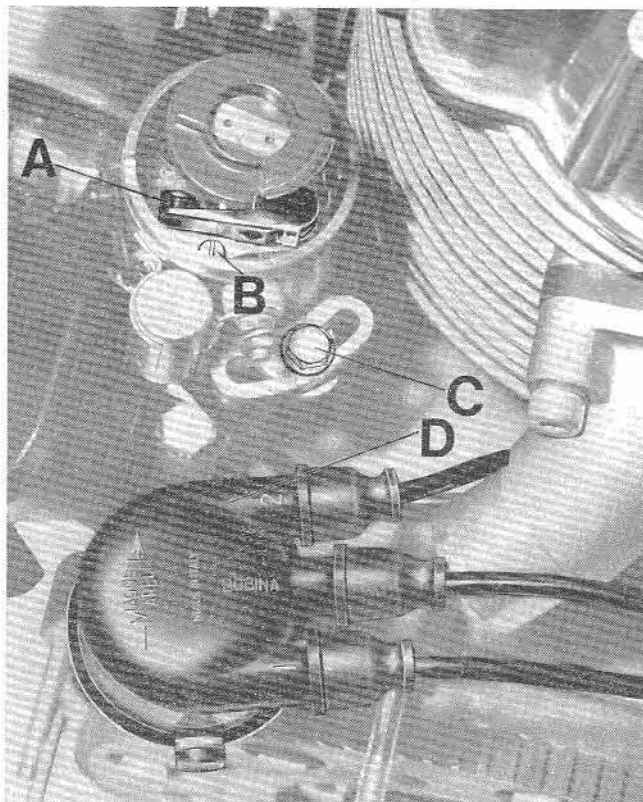

Fig. 125

If the points open before or after the specified mark, slacken distributor securing bolt (see C on Fig. 125) and turn the distributor to the right or to the left to obtain correct position in which the points will start opening at the proper time.

Fit distribution cap and connect cables to spark plugs and ignition coil. Bear in mind that cable

departing from cap outlet marked No. 2 must be connected to plug of cylinder No. 2 (L/H). Cable departing from cap outlet marked No. 1 must be connected to plug of cylinder No. 1 (R/H). Cable departing from cap outlet marked « BOBINA » must be connected to ignition coil (see Fig. 125).

IGNITION FAULTS

FAULTS	POSSIBLE CAUSES	REMEDIES
Misfiring.	<p>Grounded or uncertain H.T. connections.</p> <p>Ignition coil cap showing traces of discharge or burnouts.</p> <p>Distributor cap showing traces of discharge or burnouts.</p> <p>Distribution rotor showing traces of discharge or burnouts.</p> <p>Ignition coil with short-circuited or broken secondary winding (coil supplies very weak sparks).</p> <p>Contact breaker periodically grounded (current absorbed by primary winding does not drop to zero when points open).</p> <p>Contact breaker points are dirty, oxidated or burnout.</p>	<p>Fix or replace H.T. connections.</p> <p>Replace ignition coil.</p> <p>Replace distributor cap.</p> <p>Replace distributor rotor.</p> <p>Replace ignition coil.</p> <p>Check insulations and if necessary replace them. Clean contact breaker plate with pure gas.</p> <p>Clean contact breaker points thoroughly and if necessary smooth down surfaces using suitable file.</p>

FAULTS	POSSIBLE CAUSES	REMEDIES
Misfiring at high speed.	Irregular gap of contact breaker points, either due to excessive wear of same (gap too wide) or excessive wear of felt pad (gap too narrow).	Clean thoroughly contact breaker points and adjust gap. If necessary replace contact breaker set.
	Contact breaker points are out of alignment.	Align points, adjust gap and tighten down adjusting screw.
	Periodically short-circuited condenser, lacking insulation or broken (strong sparking at points).	Replace condenser.
	Grounded or uncertain H.T. connections.	Fix or replace H.T. connections.
	Ignition coil cap showing traces of discharge or burnouts.	Replace ignition coil.
	Distributor cap showing traces of discharge or burnouts.	Replace distributor cap.
Distributor rotor showing traces of discharge or burnouts.	Replace distributor rotor.	

FAULTS	POSSIBLE CAUSES	REMEDIES
	<p>Ignition coil with short-circuited or broken secondary winding (coil supplies very weak sparks).</p> <p>Uncertain L.T. connections.</p> <p>Contact breaker periodically grounded (current absorbed by primary winding does not drop to zero when points open).</p> <p>Contact breaker points are dirty, oxidated or burnout.</p> <p>Irregular gap of contact breaker points, either due to excessive wear of same (gap too wide) or excessive wear of felt pad (gap too narrow).</p> <p>Contact breaker points are out of alignment.</p>	<p>Replace ignition coil.</p> <p>Check connections, tighten screws and nuts, renew weldings etc.</p> <p>Check insulations and if necessary replace them. Clean contact breaker plate with pure gas.</p> <p>Clean contact breaker points thoroughly and if necessary smooth down surfaces using suitable file.</p> <p>Clean contact breaker points thoroughly and adjust gap. If necessary replace contact breaker set.</p> <p>Align points, adjust gap and tighten down adjusting screw.</p>

FAULTS	POSSIBLE CAUSES	REMEDIES
Spark failure.	Contact breaker arm too tightly fitted on its pin.	Clean and lubricate pin with few drops of suitable oil.
	Lack of pressure at contact breaker points.	Check and if necessary replace contact breaker arm. Check spring load to be as required by testing data.
	Periodically short-circuited condensor, lacking insulation or broken.	Replace condensor.
	Break in connections.	Locate break and repair or replace connections.
	Ignition coil cap perforated by H.T. or grounded.	Replace ignition coil.
	Distributor cap perforated by H.T. or grounded.	Replace distributor cap.
Distributor rotor perforated by H.T. or grounded.	Replace distributor rotor.	

FAULTS	POSSIBLE CAUSES	REMEDIES
	Short-circuited ignition coil winding (on test bed, ammeter shows absorption to be higher than normal).	Replace ignition coil.
	Grounded ignition coil primary winding (current flow does not stop even with open contact breaker points).	Replace ignition coil.
	Break in ignition coil primary winding (current does not flow thru coil).	Replace ignition coil.
	Too wide or too narrow contacts gap.	Adjust to correct gap and tighten down screw which secures fixed contact plate. If necessary replace contacts set.
	Contact breaker arm seized on pin.	Remove contact breaker arm. Clean pin and lubricate with a few drops of suitable oil. If necessary replace contact breaker arm.
	Short-circuited condensor.	Replace condensor.

ELECTRIC HORN (see Fig. 126)

The electric horn fitted on the « V7 » machine is a MARELLI T 12 DE/F type. The electric horn circuit consists of: horn - pushbutton control, located on left handlebar - ground, the latter being the frame of the machine.

Horn is provided with a diaphragm which is set into vibration by means of an electromagnet. Current flowing thru electromagnet winding originates a magnetic field, thus attracting a keeper which is secured to horn diaphragm.

The slight movement of the keeper flexes the diaphragm and at the same time electromagnet contacts open. In this condition the current does not flow anymore thru the electromagnet winding, the keeper is no more attracted and diaphragm then returns to original position. Contacts then close again and a new cycle starts.

The continuous flexure of the diaphragm causes a vibration, thus originating the sound of the electric horn.

OVERHAUL AND REPAIR INSTRUCTIONS

If electric horn is faulty in operation or fails to work at all, before stripping down make sure that possible cause is not in some other part of the electrical system.

If electric horn fails to work check that pushbutton control is not faulty and also check connections to headlight.

If electric horn gives an irregular sound, check bolts which secure horn unit to frame. If electric

horn sounds uninterruptedly, look for grounded contact in pushbutton control or in connection between pushbutton control and electric horn. Should above inspections fail to detect the fault, it is obvious that the cause lies inside electric horn and in such case it is suggested to apply to an Authorized Dealer.

To tune the sound of the electric horn, act on adjusting nut (see A on Fig. 126).

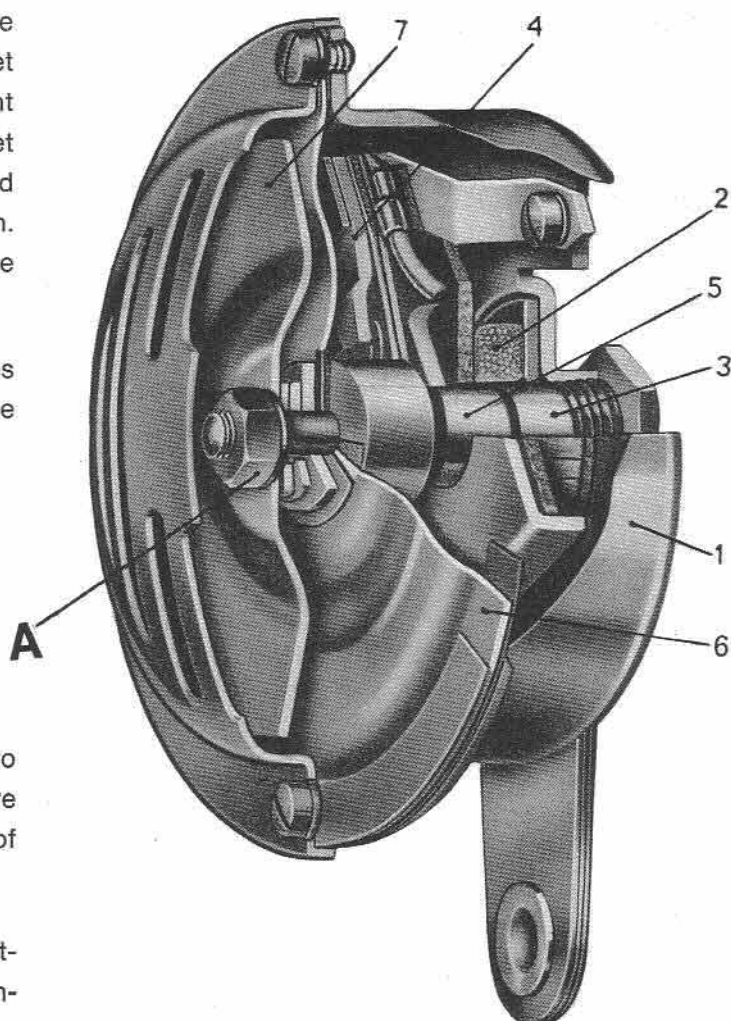

Fig. 126 - Electromagnetic horn (adjustable block core type).

1. Body - 2. Coil - 3. Core - 4. Breaker - 5. Keeper -
6. Diaphragm - 7. Resounding disc.

ELECTRIC HORN TESTING DATA

FEATURES

Type No.	Operating tension	Terminals	Cover	Support
T 12 DE/F	12 V	screw type	threaded locking ring	side bracket

Fixed air gap type electric horn, O/D mm. 103 (4.005").

ELECTRICAL DATA

Testing tension	13 V
Absorption	≤ 3 A
Coil resistance	1.02 Ω

TENSION AND INSULATION TESTS

Check dielectric rigidity by feeding for 3 sec.s with 450V, 50 Hz, A.C.

Check insulation resistance by feeding with 100V, D.C. - Resistance value must exceed 5 M Ω .

ACOUSTIC TESTS

Vibration frequency	415-440 Hz.
Sound level at a distance of 2 mt. (6.56ft)	105-125 D.B.

ELECTRIC HORN FAULTS

FAULTS	POSSIBLE CAUSES	REMEDIES
Horn fails to work.	Break in external connections.	Locate break and repair it.
	Break in internal connections.	Locate break and repair it.
	Short-circuited, broken or grounded coil.	Replace coil.
	Short-circuited condensor.	Replace condensor.
	Keeper out of adjustment.	Adjust keeper position.
	Breaker out of adjustment.	Adjust breaker.
	Dirty breaker contacts.	Clean contacts and adjust breaker.
Horn gives an irregular sound.	Burnout or unwelded breaker contacts.	Replace breaker.
	Faulty external connections.	Locate fault and repair it.
	Faulty internal connections.	Locate fault and repair it.
	Short-circuited coil.	Replace coil.
	Break in condensor.	Replace condensor.

FAULTS	POSSIBLE CAUSES	REMEDIES
Horn fails to work.	Break in external connections.	Locate break and repair it.
	Break in external connections.	Locate break and repair it.
	Short-circuited, broken or grounded coil.	Replace coil.
	Short-circuited condensor.	Replace condensor.
	Broken leaf spring	Replace leaf spring (when allowed by horn type).
	Diaphragm not correctly positioned.	Position diaphragm correctly.
	Deformed diaphragm	Replace diaphragm.
Horn sounds uninterruptedly	Horn assembly not properly secured to machine frame.	Tighten securing bolts.
	Grounded external connections.	Locate grounding and repair.
	Grounded coil.	Replace coil.

LIGHTING

12 V lighting equipment, including the following:

HEAD LIGHT (see Fig. 127)

Sealed beam insert, 168 mm. dia. (6.6"). Access inside headlight body is obtained undoing screw (1) and moving bottom side of rim so to disengage sealed beam unit from top retaining slot (2).

HEADLIGHT TERMINAL PLATE

Check good condition of all connections.

HEADLIGHT TERMINAL PLATE C/W FUSES

(see Fig. 127)

FUSES

All electricals are protected by four fuses (or more, depending on machine model). Before replacing a blown fuse it will be necessary to detect the cause, that is to say the short circuit which originated the fuse blowing. When trying to locate the fault, use wiring diagram (see Fig. 130 or 131). Replace with 25A fuses.

Fuses are located on top terminal plate, inside headlight body.

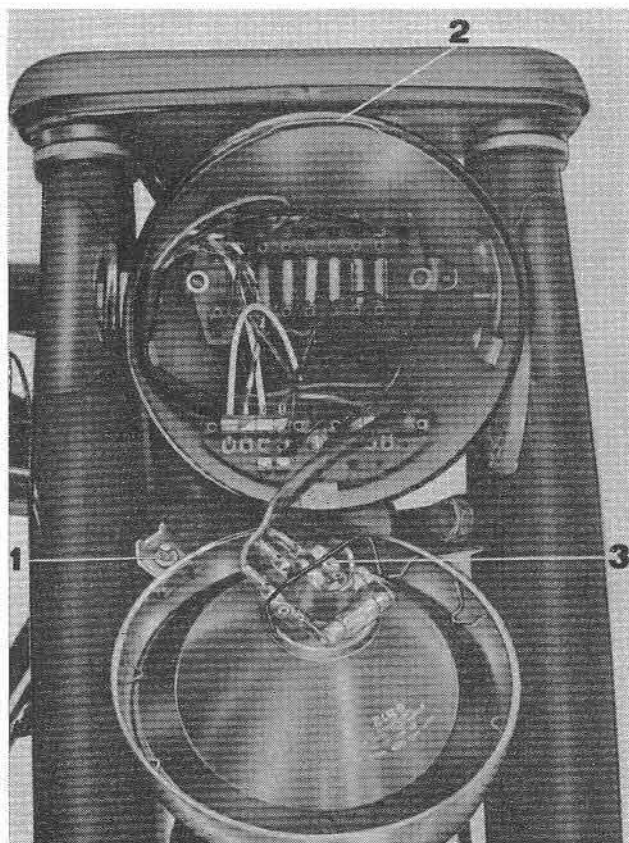

Fig. 127



Fig. 128

BULBS (12 V)

— Headlight	Sealed beam insert 168 mm. dia. (6.6")	45-40 W
— Tail light	two filament, round	20-5 W
Instruments panel: (see Fig. 128)		
— Speedometer (A)	round	3 W
— Dimmed light indicator (B)	round	3 W
— Ammeter (C)	round	3 W
— Neutral indicator (D)	round	3 W
— Oil pressure gauge (E)	round	3 W

TAIL LIGHT AND STOP LIGHT

Located in number plate holder on rear fender, fits a two-filament round bulb as shown above, secured to bayonet type lamp holder.

NB: When replacing, always use bulbs of similar type and capacity.

CABLES

Check and ensure of their perfect condition. If cracked, unwelded or deteriorated, cables must be positively replaced.

INSTRUMENTS AND CONTROLS

1 - Speedometer (See fig. 128) including:

- a) Mile calibrated clock;
- b) High beam indicator red light;
- c) Red warning light, ammeter. Indicating insufficient flow of current from generator for battery charge. Should go out when engine has reached a certain number of revolutions.
- d) Orange warning light. Neutral indicator. Does not light up when any gear is engaged;
- e) Red warning light. Oil pressure gauge. Goes out when there is sufficient oil pressure for engine lubrication.

IGNITION KEY

An ignition key and a duplicate are supplied with each machine. The number should be recorded. In case of loss, the key number should be reported to your dealer.

2 - Ignition key switch (Automotive type). This controls the entire electric equipment and engine starting. This key has the function of an antitheft device (See fig. 129).

This key has four positions:

- « 0 » = Machine at standstill, key removable, all electrics switched off.
- « 1 » = Machine standing, key removable, parking lights on.
- « 2 » = Running position or machine ready to set out. All controls on. For daylight riding no other position is necessary.
For night driving lever A on the left handlebar switch must be switched on.
- « 3 » = For starting only. The key returns automatically to position 2 when the engine has started.

4 - **Dimmer switch and horn button** (see fig. 8).

On left handlebar.

Switch A:

Position 1 = lights off

Position 2 = lights on

Switch B:

Position 3 = low beam

Position 4 = high beam

Push button C = horn control.

5 - **Twist grip throttle control**

It is fitted on the right handlebar. Throttle is opened by turning towards the rider.

6 - **Clutch lever**

It is located on the left hand handlebar and should be used only for starting and gear shifting.

7 - **Gearshift lever**

Of rocking type, on right hand side of machine.

8 - It is located on the left hand side of the machine.

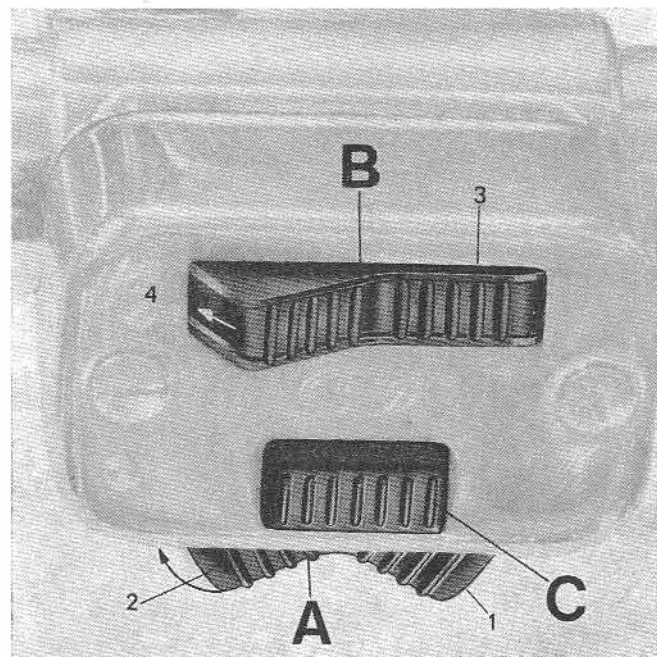

Fig. 129

KEY TO CABLE COLORS (Fig. 130) (U.S.A. MODEL)

- 1 - **Black:** battery V to starter motor relay Z
- 2 - **Red:** regulator U 51B+ to battery V +
- 3 - **Red:** battery V to ignition switch Q
- 4 - **Grey-red:** generator T to regulator U (D+)
- 5 - **White:** generator T to regulator U (DF)
- 6 - **Black:** terminal with fuses C to stop cut-out O
- 7 - **Yellow:** distributing block D to tail light bulb R
- 8 - **Green:** neutral cut-out N to warning light F on speedometer
- 9 - **Brown:** ignition switch Q (50) to starter relay Z
- 10 - **Blue-black:** terminal block C to H.T. coil I
- 11 - **Grey:** oil pressure cut-out P to speedometer L
- 12 - **Red:** generator T to warning light D on speedometer L
- 13 - **Black:** distributing block D to horn M (T—)
- 14 - **Red:** terminal block with fuses C to ignition switch Q
- 15 - **White:** distributing block D to warning bulb Q in speedometer L
- 16 - **Yellow-black:** distributing block D to warning light LA on speedometer
- 17 - **Brown:** terminal block C to ignition switch Q (Int.)
- 18 - **White-black:** terminal block C to speedometer L
- 19 - **Green:** distributing block C to light switch E
- 20 - **Green-black:** distributing block D to light switch E
- 21 - **Grey-red:** distributing block D to light switch E
- 22 - **Brown:** terminal block C to light switch E
- 23 - **Black:** distributing block D to light switch E
- 25 - **Black:** stop light cut-out O to tail light bulb S
- 26 - **Black:** regulator U to ground
- 27 - **Black:** battery V to ground
- 28 - **Black:** H.T. coil I to contact breaker H
- 29 - **Black:** H.T. coil I to distributor G
- 30 - **Black:** distributor G to spark plug F
- 31 - **Black:** distributor G to spark plug F
- 37 - **Black:** headlight earth to frame

- 41 - **Green-black:** distributing block D to high beam filament B
- 42 - **Green:** distributing block D to low beam filament B
- 41 - **Black:** headlight bulb B to ground on distributing block D

IGNITION KEY SWITCH

- 0 —
- 1 — 30/30 int.
- 2 — 30/30 int. 15/54
- 3 — 30/30 int. 15/54 - 50

WIRING DIAGRAM

- A - Headlight
- B - Main light bulb
- C - Terminal block with fuses
- D - Distributing block
- E - Light switch and horn button
- F - Spark plug
- G - Distributor
- H - Contact breaker
- I - H. T. coil
- L - Speedometer and warning light bulbs
- M - Horn
- N - Neutral indicator cut-out
- O - Stop light cut-out
- P - Oil pressure cut-out
- Q - Ignition switch
- R - Number plate and tail light
- Plate illumination and stop light
- T - Generator
- U - Regulator
- V - Battery
- Z - Starter motor relay
- X - Starter motor

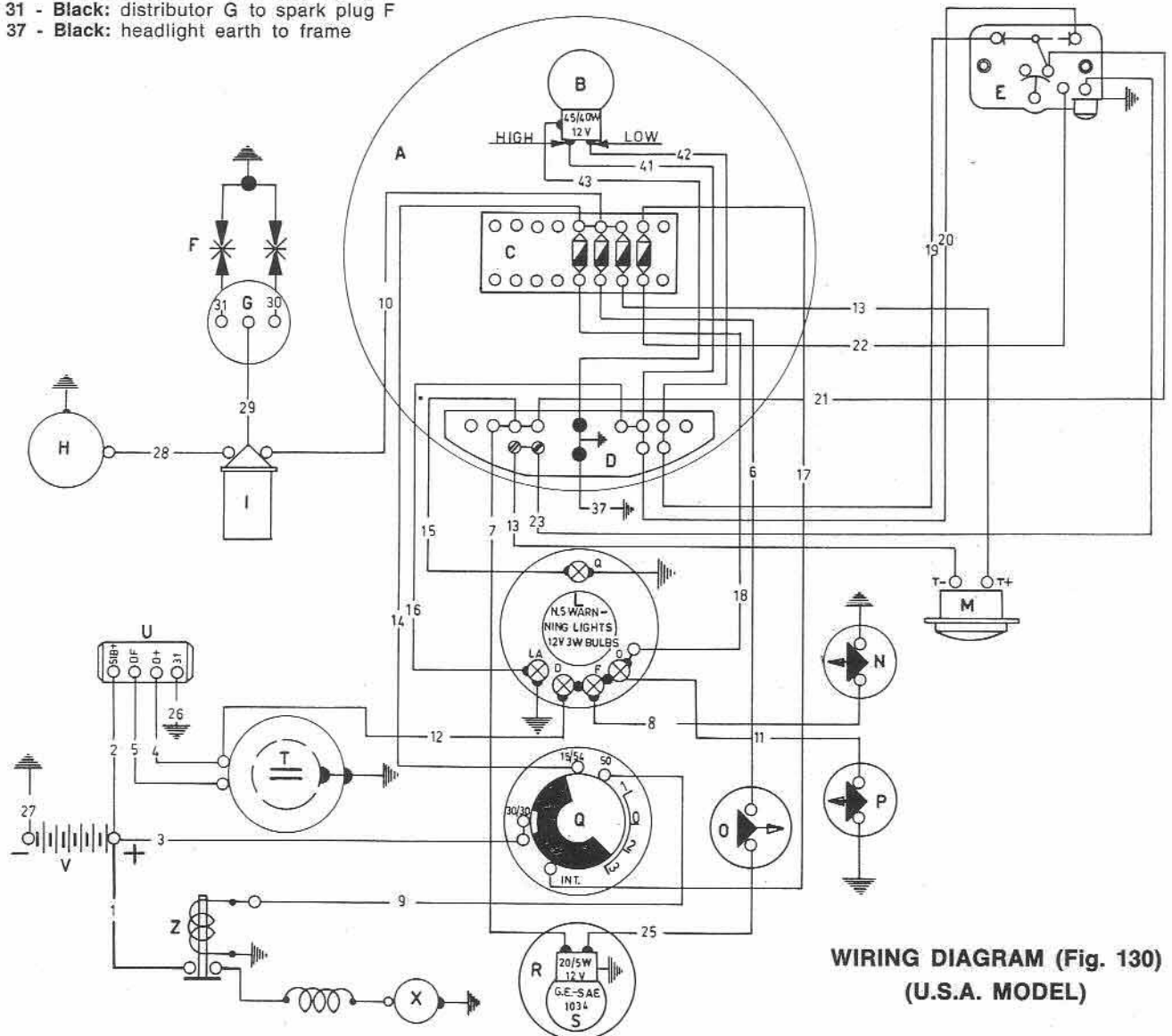

WIRING DIAGRAM (Fig. 130)
(U.S.A. MODEL)

STANDARD HEADLIGHT (Fig. 130/1)

All machines for sale in Italy and in countries other than USA are equipped with a different type headlight with a two-filament 12 V 45/40 W high and low beam round bulb and an elongated bulb for town driving. Both models incorporate the same type light switch and the town light is switched on by pushing A to the right.

KEY TO CABLE COLORS

- 1 - **Black:** battery + to starter motor
- 2 - **Red:** battery to regulator 51 B +
- 3 - **Red:** ignition switch 30/30 to battery +
- 4 - **Grey-red:** regulator to generator D +
- 5 - **White:** regulator DF to generator DF
- 6 - **Black:** terminal with fuses to stop cut-out
- 7 - **Yellow:** distributing block to tail light bulb
- 8 - **Green:** instrument board F to neutral indicator cut-out
- 9 - **Brown:** ignition switch to starter motor
- 10 - **Blue-black:** terminal block to coil
- 11 - **Grey:** instrument panel 0 to oil pressure solenoid
- 12 - **Red:** instrument panel D to generator D +
- 13 - **Black:** terminal box with fuses to horn
- 14 - **Red:** ignition switch 15/54 to terminal block
- 15 - **White:** instrument panel Q to distributing block

- 16 - **Yellow-black:** instrument panel LC to distributing block E
- 17 - **Brown:** ignition switch int. to terminal block with fuses
- 18 - **White black:** instrument panel D to terminal block with fuses
- 19 - **Green:** light switch to headlight bulb
- 20 - **Green-black:** light switch to headlight bulb
- 21 - **Grey-red:** light switch to distributing block
- 22 - **Brown:** light switch to terminal with fuses
- 23 - **Black:** horn button to distributing block
- 24 - **Blue:** town driving bulb to distributing block
- 25 - **Black:** stop cut-out to stop bulb
- 26 - **Black:** regulator to ground
- 27 - **Black:** battery to ground
- 28 - **Black:** H.T. coil to contact breaker
- 29 - **Black:** H.T. coil to distributor
- 30 - **Black:** distributor to spark plug
- 31 - **Black:** distributor to spark plug
- 37 - **Black:** headlight D to ground

IGNITION KEY SWITCH

- 0 —
- 1 — 30/30 int.
- 2 — 30/30 int. 15/54
- 3 — 30/30 int. 15/54 - 50

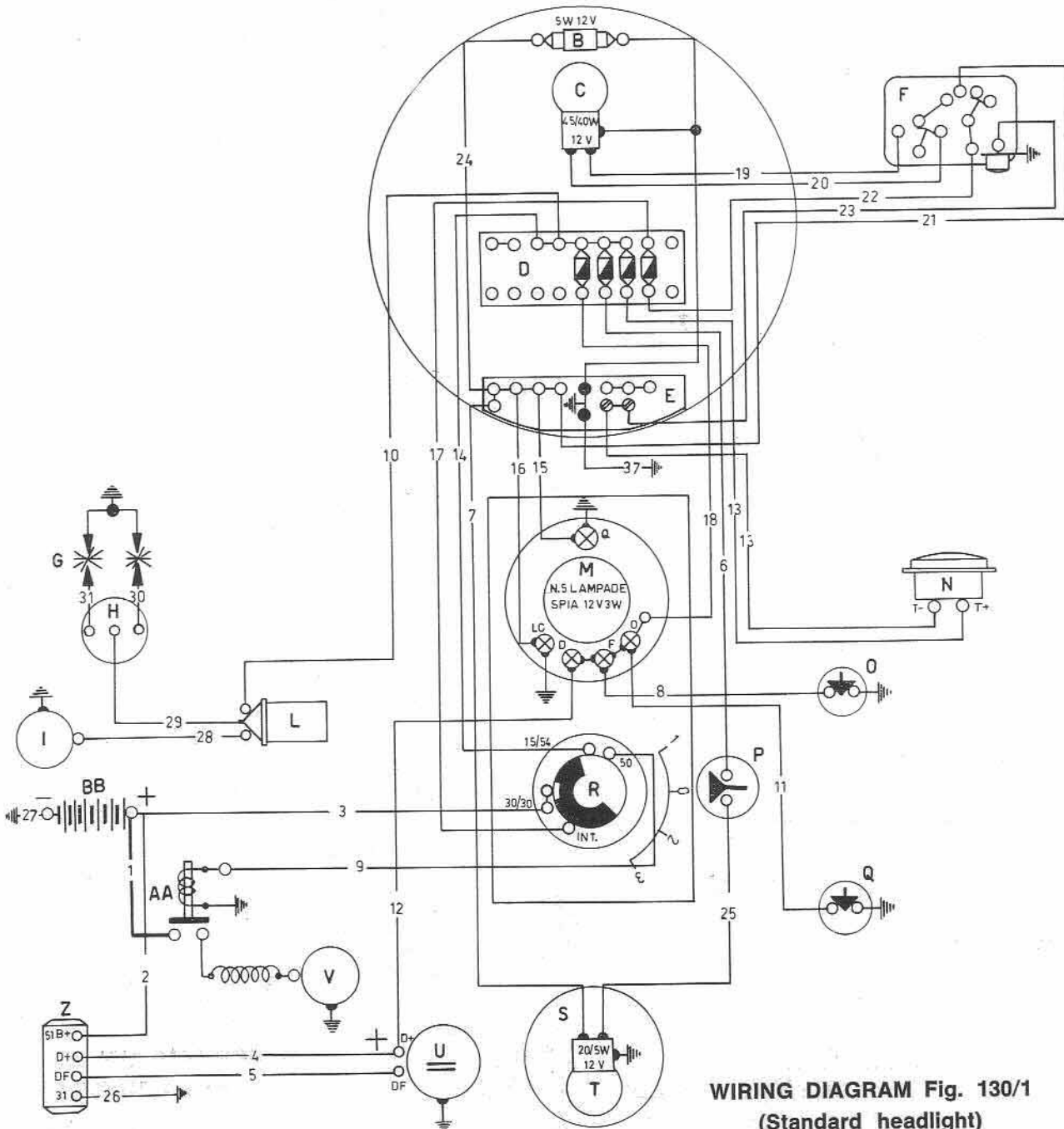

WIRING DIAGRAM Fig. 130/1
(Standard headlight)

WIRING DIAGRAM (Standard headlight)

- A - Headlight
- B - Town driving light
- C - Main light bulb
- D - Terminal block with fuses
- E - Distributing block
- F - Light switch and horn button
- G - Spark plug
- H - Distributor
- I - Contact breaker
- L - H. T. coil
- M - Speedometer and warning light bulbs
- N - Horn
- O - Neutral indicator cut-out
- P - Stop light cut-out
- Q - Oil pressure cut-out
- R - Ignition switch
- S - Number plate and tail light
- T - Plate illumination and stop light
- U - Generator
- V - Starter motor
- Z - Regulator
- AA - Starter motor relay
- BB - Battery



- 6 - Check and if necessary top up oil level in crankcase. Correct level is in between the minimum and maximum marks on the dipstick. See « Engine lubrication ».

Every 1000 kms. (600 miles)

- 7 - Lubricate cable ends. See « Lubrication of clutch, front brake, and air cables ».

Every 3000 kms. (1800 miles)

- 8 - Replace oil in crankcase. See « Engine lubrication ».
- 9 - Check tappet clearance. See « Tappet clearance ».
- 10 - Check and clean spark plugs. See « spark plugs ».
- 11 - Check oil level in gearbox and if necessary top up. See « Lubrication of gear box ».
- 12 - Check oil level in transmission box for lubrication of bevel gears. If necessary, top up.
- 13 - Clean petrol cocks and filters, carburetor filter, and fuel line to carburetors. See « Carburation ».

Every 10000 kms. (6000 miles)

- 14 - Strip carburetor and check all parts. Using an air jet, clean out all ducts. See « Carburation ».
- 15 - Change gearbox oil. See « Lubrication of transmission ».
- 16 - Change rear wheel drive box oil. See « Lubrication of rear wheel drive ».
- 17 - Check cleanliness and tightness of all battery connections and smear them with vaseline. See « Battery ».
- 18 - Clean generator commutator using a clean cloth slightly moistened in petrol. See « Generator ».

After the first 20000 kms. (12000 miles)

- 19 - Check condition of wheel bearings and if still efficient pack these with grease. See « Lubrication of wheel bearings ».
- 20 - Check condition of steering bearings and if still good, pack with grease.
- 21 - Replace oil in fork inner tubes. See Lubrication of fork.
- 22 - Clean starter motor commutator using a clean rag lightly moistened in petrol.

LUBRICATION AND GENERAL MAINTENANCE

(See Chart fig. 131)

Monthly

- 1 - Check electrolyte level in battery (every 15 days in summer). See « Battery ».

Periodically

- 2 - Check tire pressure with a gauge (see page 10).

After the first 500 kms. (300 miles)

- 3 - Replace the crankcase oil. See « Engine lubrication ».
- 4 - Tighten all nuts and bolts.
- 5 - Check and adjust tappet play, if necessary. See « Tappet Adjustment ».

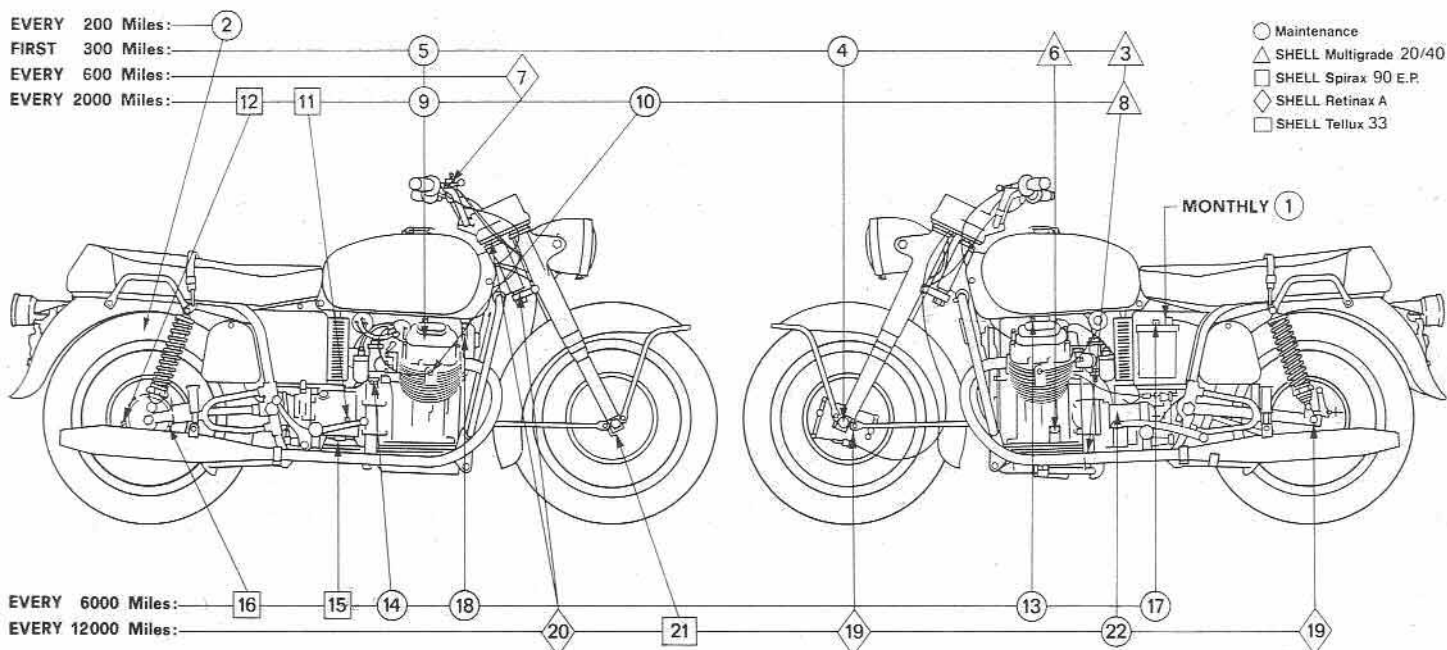

Fig. 131

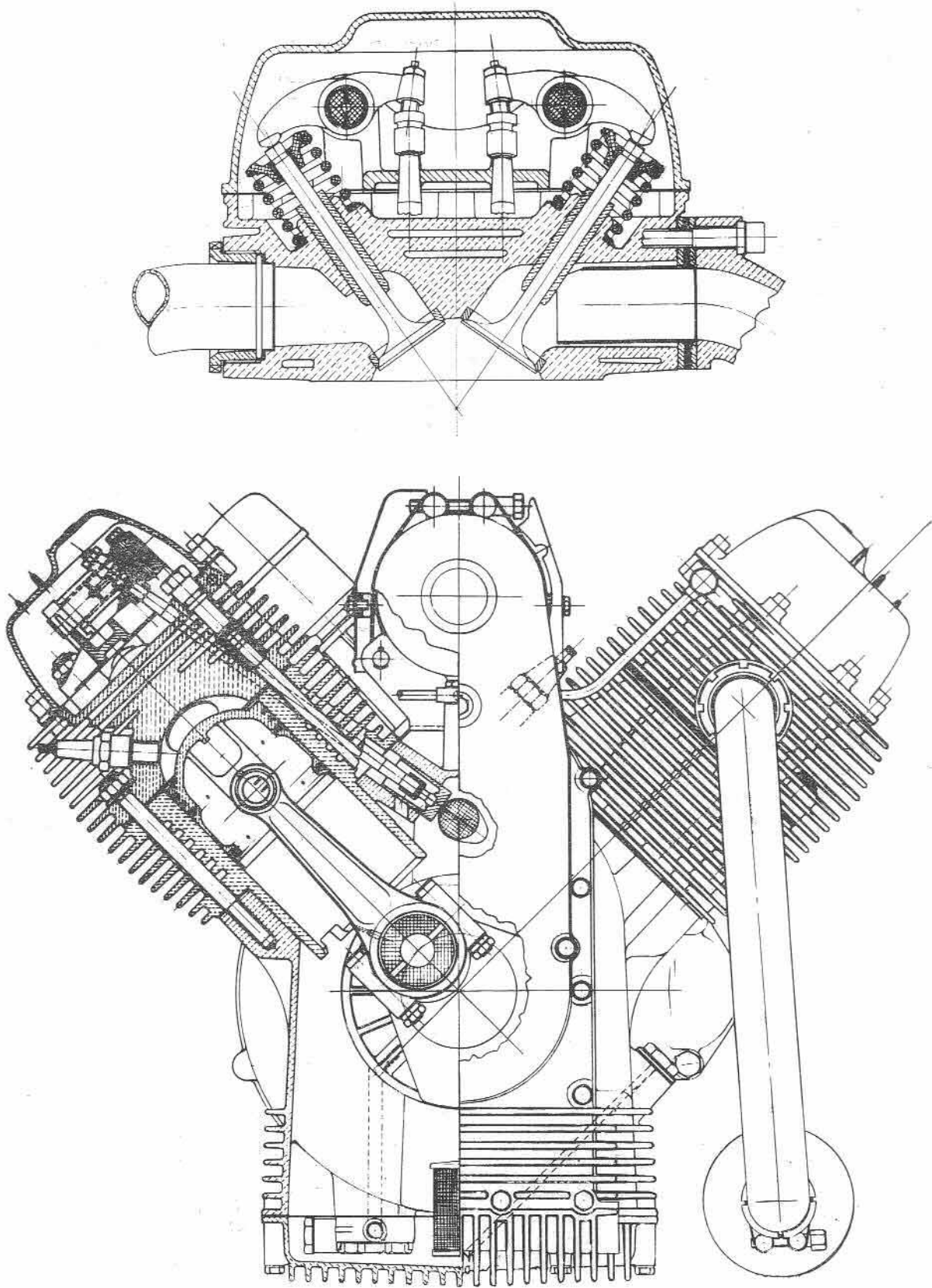

Fig. 132 Front view of engine showing sectional drawing of valve gear mechanism.

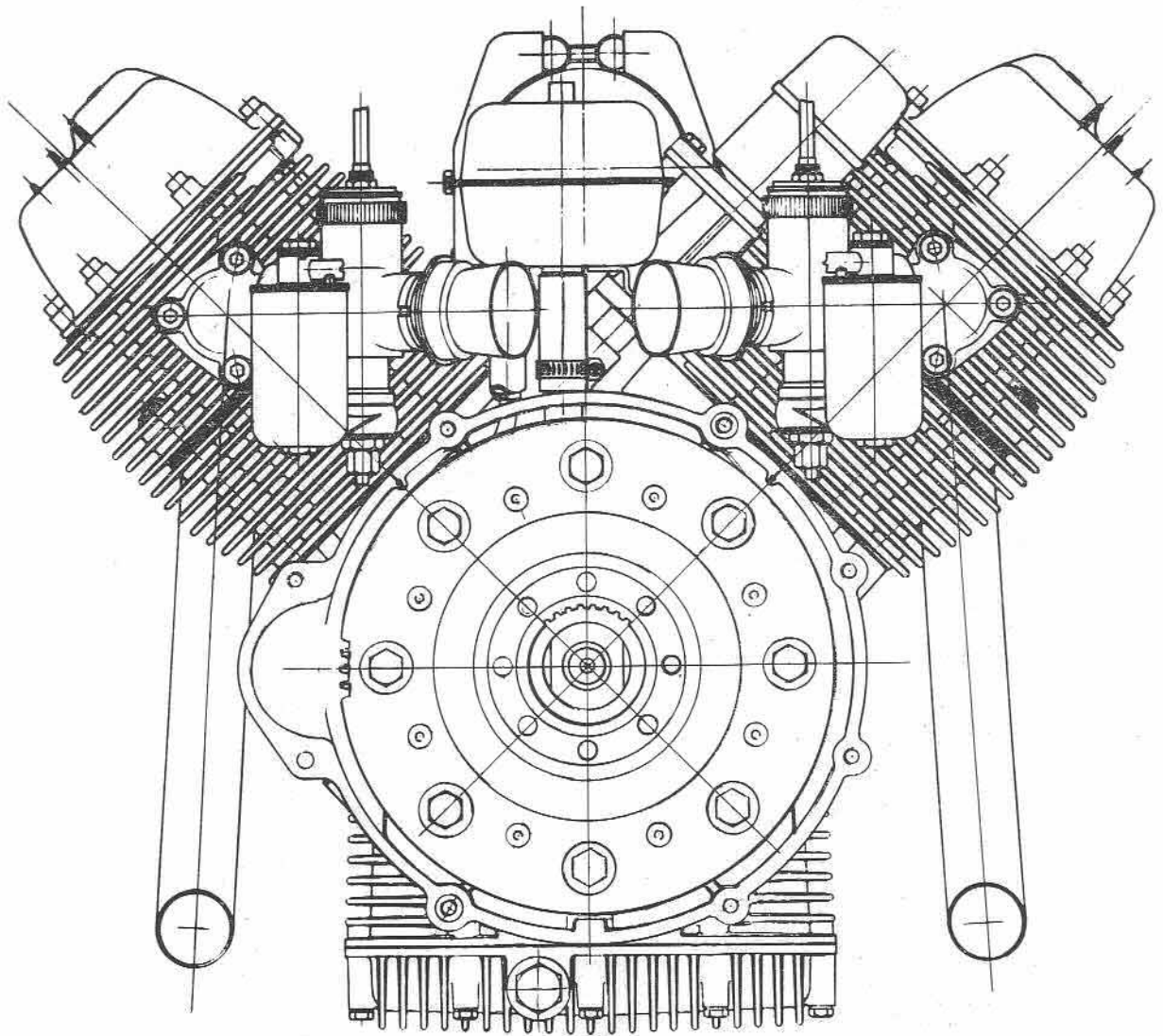

Fig 133 Rear view of engine-clutch side

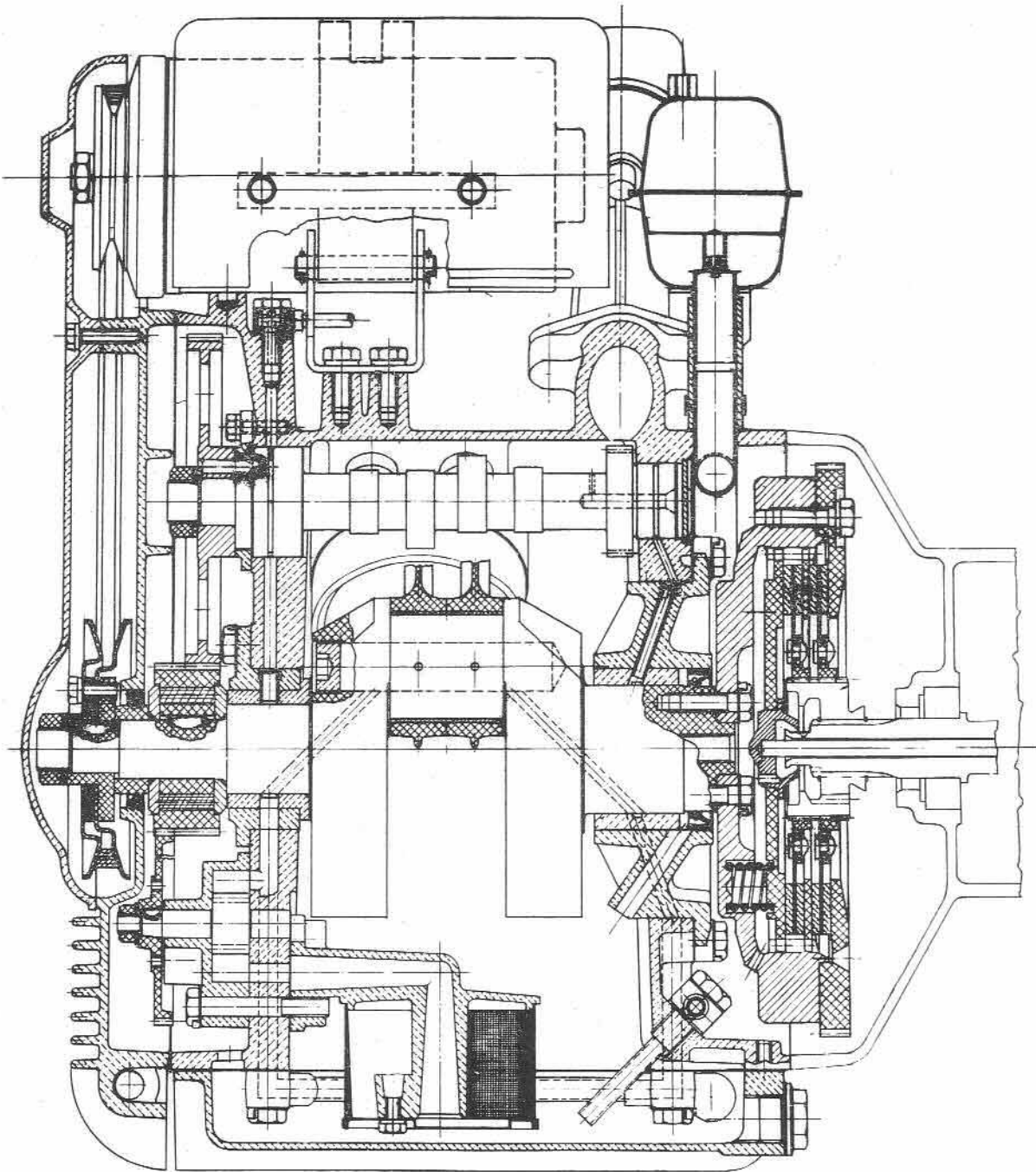

Fig. 134 Vertical section of engine

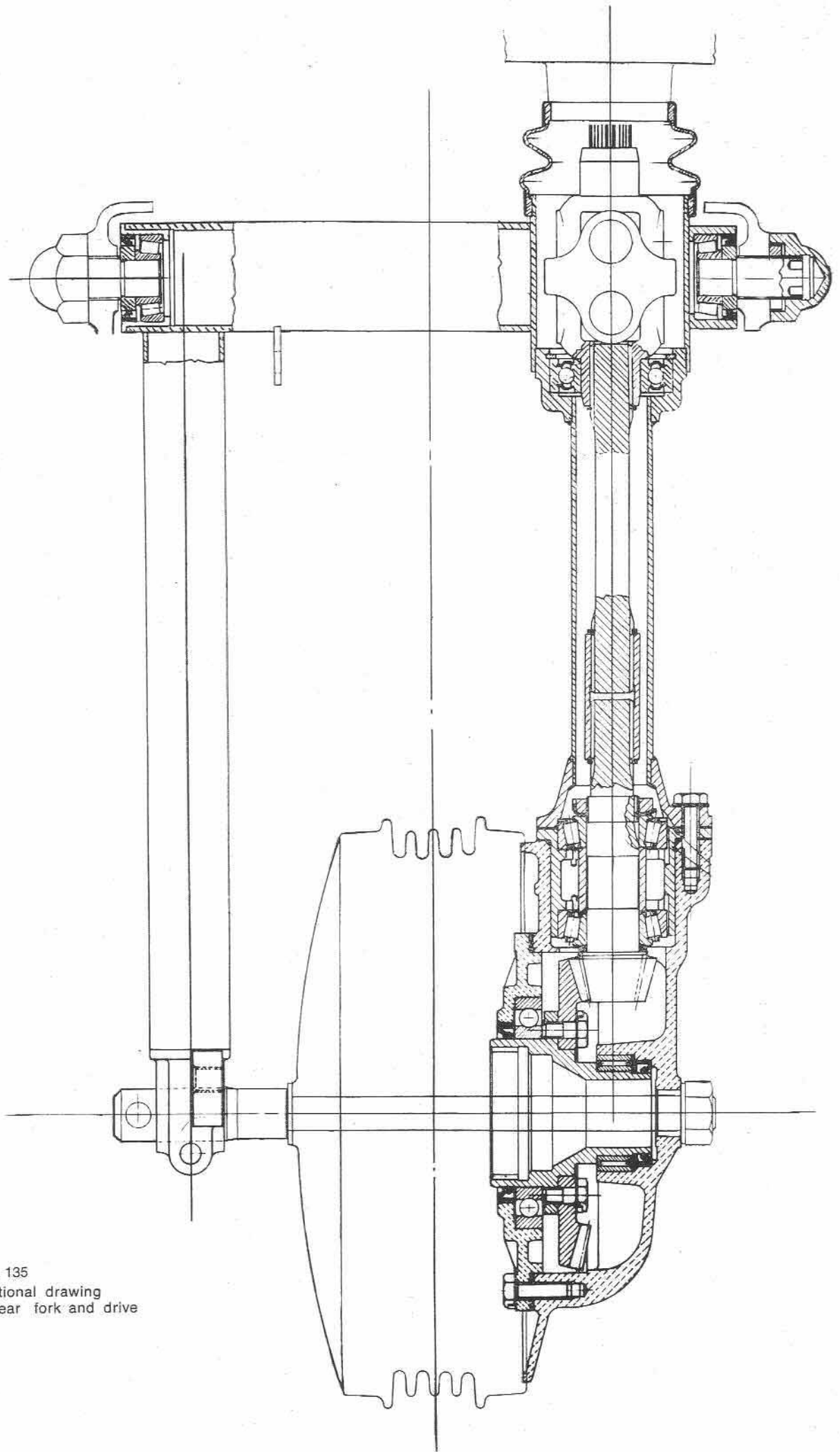

Fig. 135
Sectional drawing
of rear fork and drive



MOTO GUZZI